

IP/ PoE Transmission

User Manual

Model: IP09PHK

90W 4 Port Long Reach PoE Extender over CAT5e

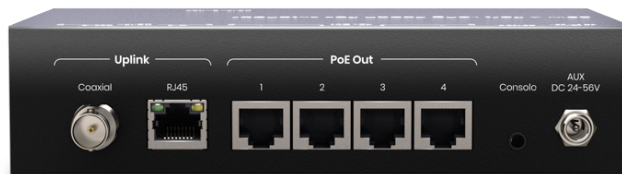

Introduction

IP09PHK is a 90W 4 port PoE switch device that can extend the PoE signal for up to 500M to enable 4 PoE devices. It can perfectly work with PoE cameras to establish an advanced CCTV system used in large scale spaces, such as road intersections, supermarkets, amusement parks, parking garages and so on.

Features

- Must work with IP09PR.
- Extends 4 PoE signals over a coaxial cable, with a distance up to 500M.
- Network bandwidth up to 100Mbps.
- Supports IEEE 802.3af, and 802.3at PoE, Max. 30W for each port.
- Power from IP09PR or an external power adapter.
- Built-in a thermostatic fan.
- Built-in 15kV ESD, 40A EFT, and 25A surge protection on the RJ45 ports.

Diagram

Power from a PoE Switch

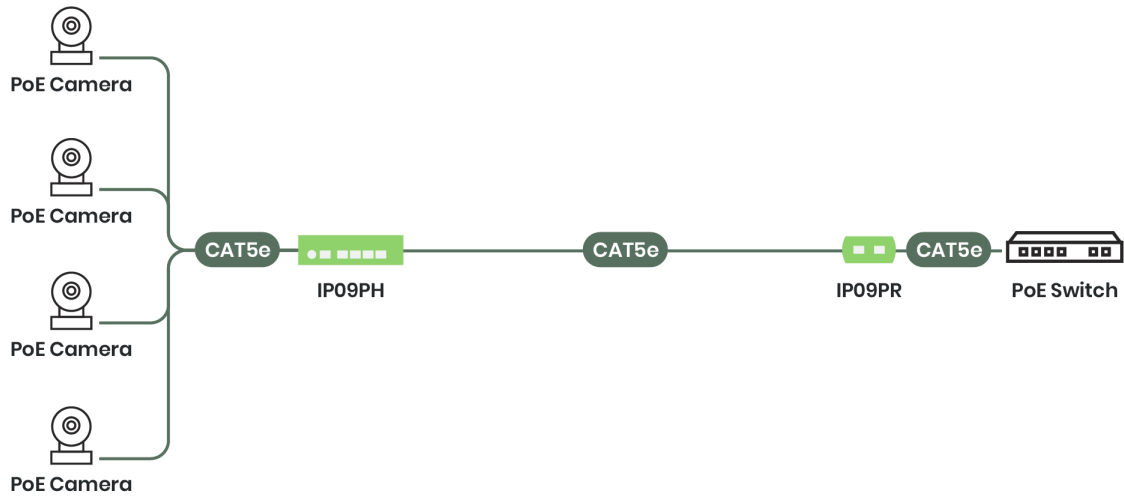

Power from a Power Adapter at IP09PR

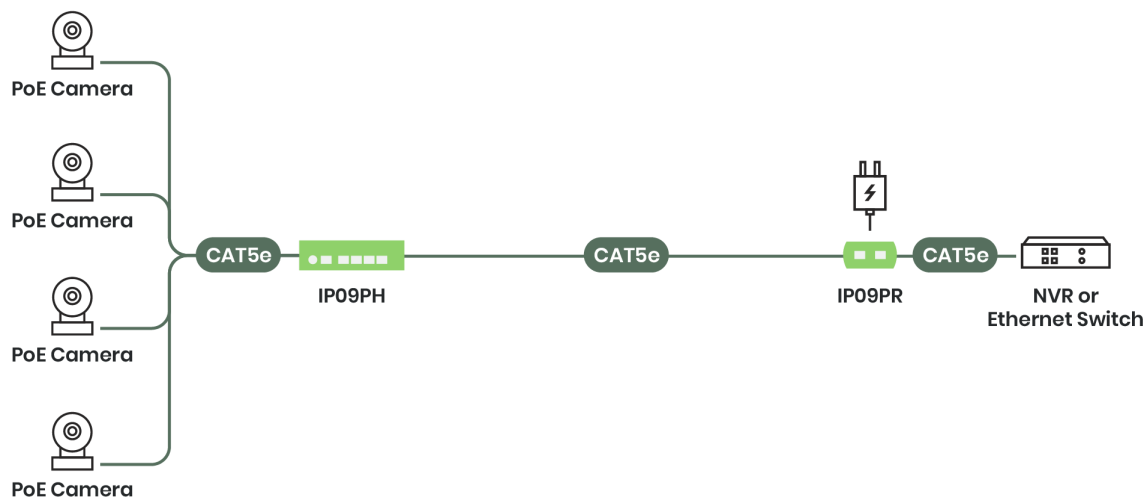

Power from a Power Adapter at IP09PH

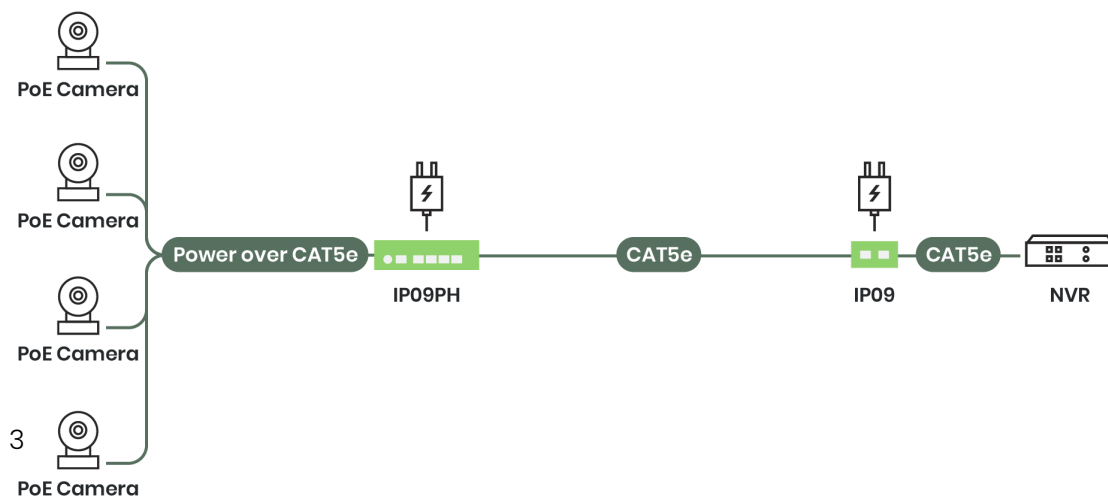

Panel View

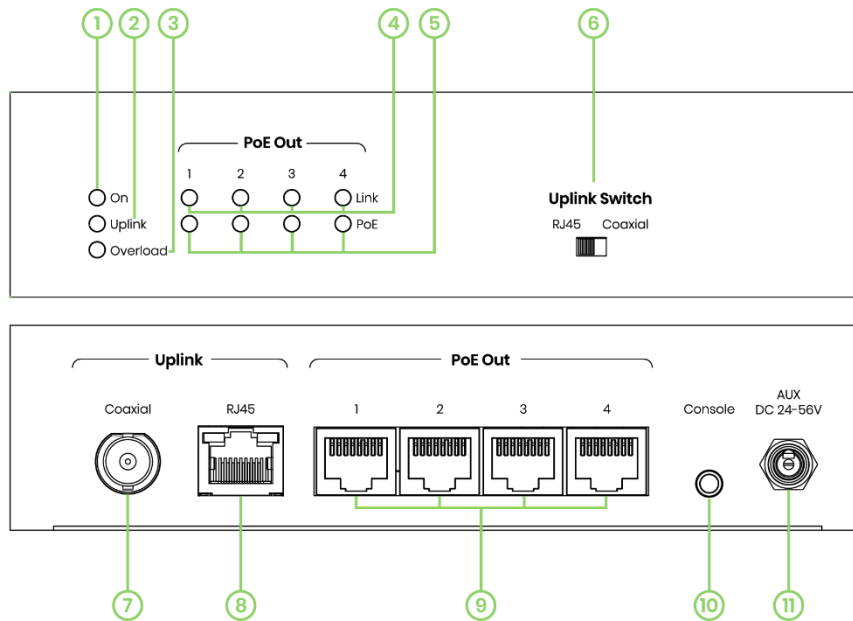

No	Interface	Function
1	On	To indicate the power status.
2	Uplink	To indicate the uplink status.
3	Overload	To indicate the status of PoE load.
4	Link 1-4	To indicate the link output status.
5	PoE 1-4	To indicate the PoE connection status.
6	Uplink Switch	To switch uplink interfaces.
7	Coaxial	To connect IP09CPR.
8	RJ45	To connect IP09PR
9	PoE Out	To connect network devices.
10	Console	To update firmware.
11	AUX DC 24-56V	To connect a power adapter.

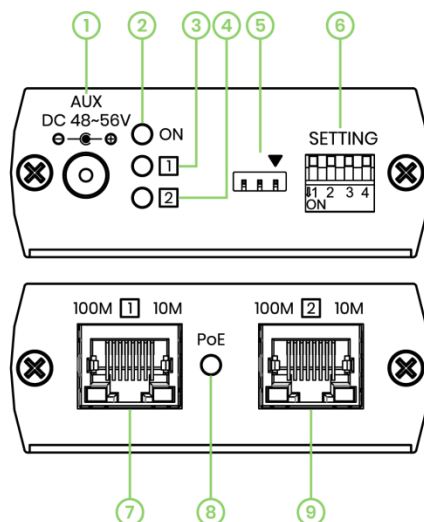

No	Interface	Function
1	Power Jack	To connect with DC48 ~ 56V adapter.
2	Power LED	To indicate the power status.
3	PortMode LED	To indicate the status of port Mode.
4	PortMode LED	To indicate the status of port Mode.
5	Jumper	Reserved.
6	DIP Switch	To switch modes.
7	RJ45	To connect a network device.
8	PoE LED	To indicate the PoE connection status.
9	RJ45	To connect IP09PH.

Description 1 – LED Indication

IP09PH LED Indicators

Front LED Color	Function	LED OFF	LED ON	LED Blinking
Green (On)	Power Status	Power OFF	Power ON	
Blue (Uplink)	Uplink Status	Unlinked	100Mbps	10Mbps
Red (Overload)	Overload Status	Normal	Power Overload	
Green (Link)	Port 1-4 Status	Unlinked	Linked	Data Transferring
Blue (PoE)	Port 1-4 PoE Status	PoE OFF	PoE ON	

Rear LED Color	Function	LED OFF	LED ON	LED Blinking
Green (RJ45)	Link Status	Unlinked	Linked	Data Transferring
Yellow (RJ45)	Link Status	Unlinked	Linked	Data Transferring

IP09PR LED Indicators

Front LED Color	Function	LED OFF	LED ON	LED Blinking
Green (ON)	Power Status	Power OFF	Power ON	Power Saving (Breathing)
Blue (1)	Port 1 Mode Status	Unlinked/Standard Ethernet Mode		100BASE-T1 (Constantly Blinking) Hardware Failure (Blink Twice)
Blue (2)	Port 2 Mode Status	Unlinked/Standard Ethernet Mode		100BASE-T1 (Constantly Blinking) Hardware Failure (Blink Twice)

Rear LED Color	Function	LED OFF	LED ON	LED Blinking
Blue (PoE)	PoE Status	PoE OFF	PoE ON	

Description 2 – RJ45 Pinout

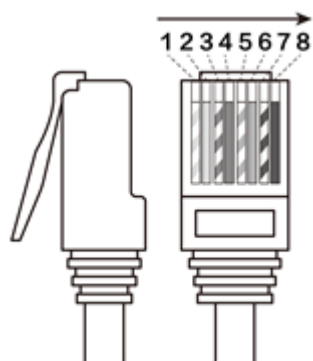

IP09PH Port 1-4

PIN	Color	Data	PoE
1	Orange-white	TX+	PoE+ (Data Pair)
2	Orange	TX-	PoE+ (Data Pair)
3	Green-white	RX+	PoE- (Data Pair)
4	Blue		PoE+ (Spare Pair)
5	Blue-white		PoE+ (Spare Pair)
6	Green	RX-	PoE- (Data Pair)
7	Brown-white		PoE- (Spare Pair)
8	Brown		PoE- (Spare Pair)

IP09PH Uplink

PIN	Color	Data	PoE
1	Orange-white	DATA 1 +	Power+
2	Orange	DATA 1 -	Power+
3	Green-white	DATA 2 +	Power-
4	Blue		Power+
5	Blue-white		Power+

6	Green	DATA2 -	Power-
7	Brown-white		Power-
8	Brown		Power-

IP09PR

Pin	Color	Data	PoE
1	Orange-white	TX+ (DATA1+)	PoE+ (Data Pair)
2	Orange	TX- (DATA1-)	PoE+ (Data Pair)
3	Green-white	RX+ (DATA2+)	PoE- (Data Pair)
4	Blue		PoE+ (Spare Pair)
5	Blue-white		PoE+ (Spare Pair)
6	Green	RX- (DATA2-)	PoE- (Data Pair)
7	Brown-white		PoE- (Spare Pair)
8	Brown		PoE- (Spare Pair)

Description 3 – Transmission Performance

Refer to the charts below to find the power amount in different distances (the distance is measured from Rx to IP09PH).

Cable	Power Supply	100M	200M	300M	400M	500M
Network Bandwidth						
		100Mbps	100Mbps	100Mbps	100Mbps	100Mbps
Power Output (IP09PH)						
CAT5e	90W PoE Switch	71.6W	51.6W	34.9W	25.8W	18.9W
CAT6	56V 120W Power Adapter at IP09PR	72W	51W	33W	26W	20W
CAT6	48V 120W Power Adapter at IP09PR	51W	33W	24W	17W	13W

Remark

1. Distance may vary by cable quality, installation, and the performance of connected devices.
2. Using CAT.5e UTP/ STP/ FTP, CAT.6 UTP, and 75Ω coaxial cables is recommended.
3. Using Ethernet (Solid Conductor) and coaxial (Solid Center Conductor) cables is recommended, other types of cable may affect the performance of power transfer.
4. Refer to PSE & PD Chart below to calculate power input for PD.

PSE & PD Chart

Class	Standard	IP09PH Output	PD Input
Class 0	IEEE 802.3af	15.4W	12.95W
Class 1		7W	3.84W
Class 2		13W	6.49W
Class 3		15.4W	12.95W
Class 4	IEEE 802.3at	30W	25.5W
Class 5	IEEE 802.3bt	45W	40W
Class 6		60W	51W
Class 7		75W	62W

Description 4 – Uplink Switch Setting

Uplink Switch

RJ45 Coaxial



Switch	Function
RJ45	Use RJ45 as uplink interface
Coaxial	Use BNC as uplink interface

Description 5 – Jumper Setting

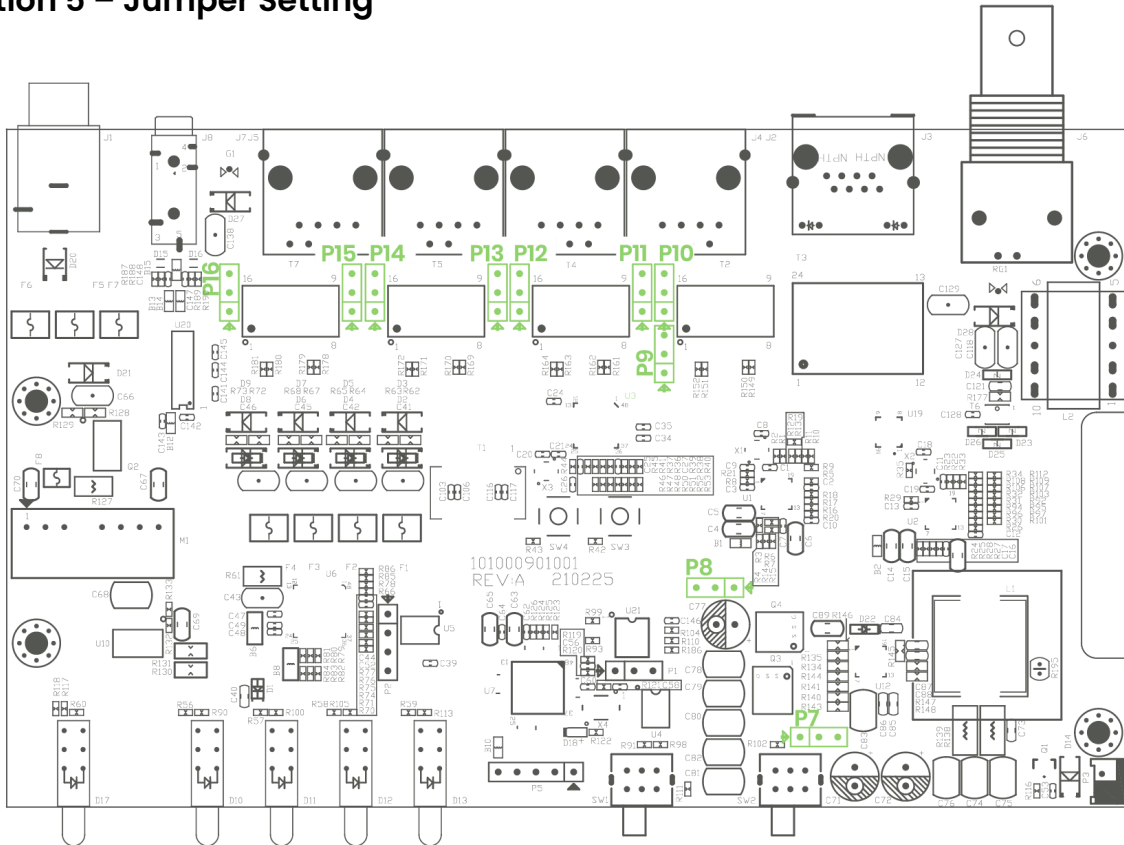

- ⊗ Improper adjustment may damage the devices.
- ⊗ Turn off the power and unplug all cables before adjustment.

Pin	Function	Settings	Description
P7	Voltage Boost	Jumper cap on pin 1 & 2	Enable (Default)
		Jumper cap on pin 2 & 3	Disable
P8	Voltage Select	Jumper cap on pin 1 & 2	Boost voltage (Default)
		Jumper cap on pin 2 & 3	No boost voltage
P9 & P10	Port 1 PoE	Jumper cap on pin 1 & 2	End-spin (Default)
		Jumper cap on pin 2 & 3	Mid-spin
P11 & P12	Port 2 PoE	Jumper cap on pin 1 & 2	End-spin (Default)
		Jumper cap on pin 2 & 3	Mid-spin
P13 & P14	Port 3 PoE	Jumper cap on pin 1 & 2	End-spin (Default)

		Jumper cap on pin 2 & 3	Mid-spin
P15 & P16	Port 4 PoE	Jumper cap on pin 1 & 2	End-spin (Default)
		Jumper cap on pin 2 & 3	Mid-spin

Caution

- Using a 56V power adapter to avoid power loss in long distance transmission is recommended.
- Using copper clad steel and stranded cables may compromise the performance of power transfer.

Package

Item		
1	IP09PH	x 1 pc
2	IP09PR	x 1 pc
3	Screw	x 6 pc
4	Wall Plug	x 6 pc
5	Rubber Pad	x 1 bag

Specification

Model	IP09PH	IP09PR
Compliance		
Standard	IEEE 802.3 10BASE-T Ethernet IEEE 802.3u 100BASE-TX Fast Ethernet IEEE 802.3 N-Way Auto-Negotiation IEEE 802.3x Full Duplex Operation and Flow Control IEEE 802.3af Power over Ethernet IEEE 802.3at Power over Ethernet Plus	
Network Bandwidth	10/ 100Mbps	
Max. Transmission Distance	10Mbps@1000M 100Mbps@500M	
Ports & Interfaces		
Input	1 x BNC (75Ω), 1. x RJ45 (Yellow)	1 x RJ45
Output	4 x RJ45 (Black)	1 x RJ45
Power Input	1 x (5.5 x 2.1mm) DC Jack	1 x (5.5 x 2.1mm) DC Jack
Power		
Power Supply	DC 24~ 56V Regulated	48 ~ 56V Regulated
Power Consumption	6W	1W
Ambient Temperature		
Operation	0 to 50°C	
Storage	-20 to 85°C	
Humidity	up to 95%	
Physical Characteristics		
Dimension	167 x 112.5 x 40mm	67 x 135 x 27mm
Weight	-	215g

Installation Guide

Step 1 – Drill 2 holes on a platform and insert 2 wall plugs

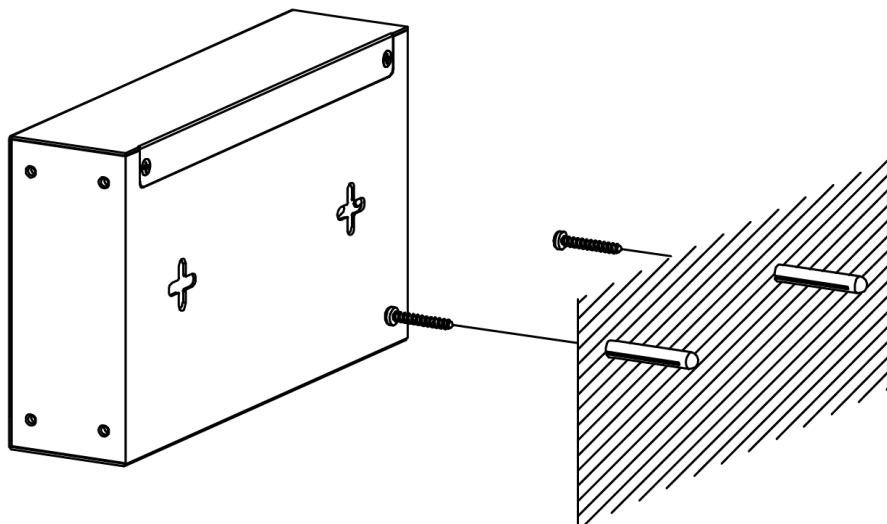

Step 2 – Put 2 screws into the plugs leaving 2mm distance from the wall

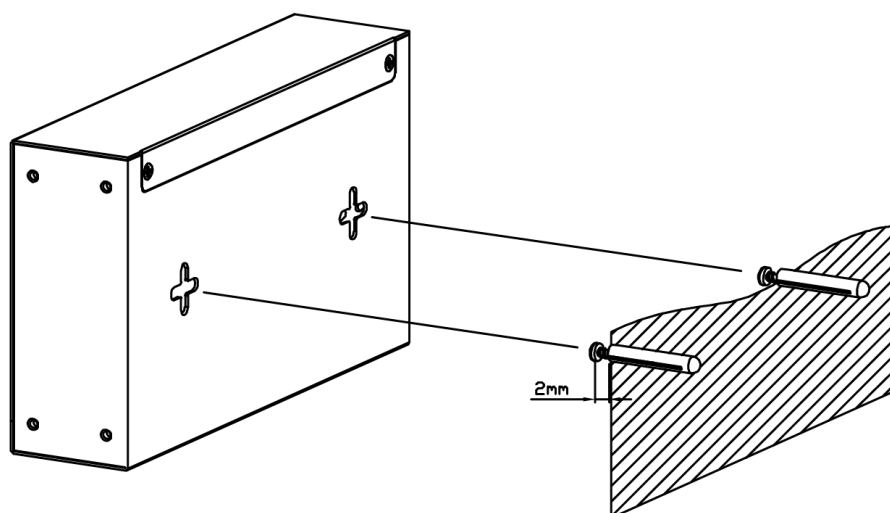

Step 3 – Fit IP09PH in the position corresponding to the screws

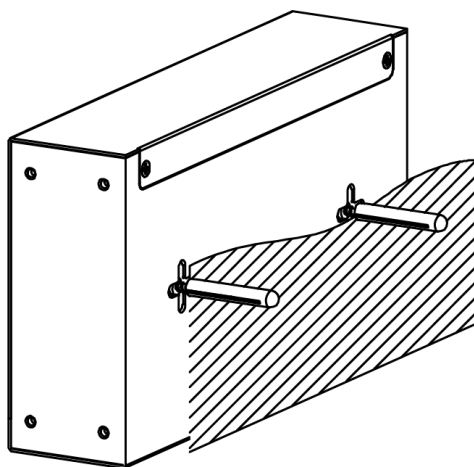

Step 4 – Move downwards to get fixed

