

# Globalmediapro Fantail HA-U1 USB to Analog Audio Converter



Operation Manual

# CONTENTS

<b>1. Introduction</b> .....	<b>1</b>
<b>2. Applications</b> .....	<b>1</b>
<b>4. System Requirements</b> .....	<b>1</b>
<b>5. Features</b> .....	<b>2</b>
<b>6. Operation Controls and Functions</b> .....	<b>3</b>
6.1 Front Panel.....	3
6.2 Rear Panel.....	4
<b>7. RS-232 control</b> .....	<b>5</b>
7.1 RS-232 Protocol.....	5
7.2 RS-232 Command.....	6
<b>8. Connection Diagram</b> .....	<b>8</b>
<b>9. Specifications</b> .....	<b>9</b>

## 1. INTRODUCTION

The Audio Center is designed to allow multiple audio sources to be controlled, switched and output to a variety of audio equipment. With its 3 audio inputs and 2 audio outputs (including a 6.3mm headphone output) you can integrate and convert USB/Line in audio source to LPCM 2CH output synchronously to Line out and 6.3mm headphone.

## 2. APPLICATIONS

- Multiple input/output Audio Center
- PC/Mac USB audio input support
- Show event audio set up
- Home theater
- Educational/Lecture presentation

## • 3. PACKAGE CONTENTS

- 1 x Audio Center
- 1 x 5V DC Power Adaptor
- 1 x 6.3mm to 3.5mm Jack
- 1 x 3.5mm to D-sub 9 pin cable
- Operational Manual

## 4. SYSTEM REQUIREMENTS

Input audio source equipment such as PC (USB), DVD player, MP3 and ...etc. with output active speakers, amplifier or headphones.

## 5. FEATURES

- Supports Digital to Analog audio Conversion (DAC)
- Supports USB sampling rate up to 192kHz
- Synchronous output sound on both Line out and 6.3mm headphone
- Supports RS-232 controls
- Elegant design and easy to install/using
- Total Harmonic Distortion (THD): Less than 100dB (-20dBfs)
- Volume control of analog and headphone outputs
- Direct power and mute button on unit
- Headphone output fades in after system is muted
- 6.3mm headphone output (3.5mm mini-jack adaptor supplied)

## 6. OPERATION CONTROLS AND FUNCTIONS

### 6.1 Front Panel

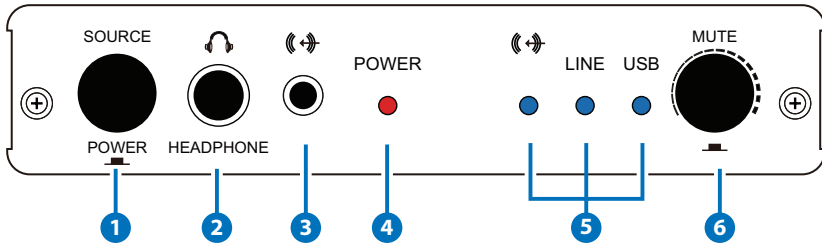

#### 1 POWER/SOURCE Select:

Press the wheel to turn on the device or to set it to standby mode. Turn the wheel Left/Right to select input audio source (3.5mm Line-level/ Line in/ USB), the LED will illuminate accordingly with selected input audio source.

#### 2 6.3mm HEADPHONE Output:

Connect to 6.3mm professional headphone set for user to enjoy the individual professional audio sound.

#### 3 3.5mm Line-level input:

Connect 3.5mm mini-jack cable to any audio equipment for stereo input audio signal.

#### 4 Power LED:

LED will illuminate when the Power is switched ON.

#### 5 Input LED indicator:

The LED will illuminate according with selected input source.

#### 6 Mute/Volume control:

Turn the wheel to adjust the volume levels. Press the wheel to Mute the audio, all the input audio LED indicator will turn off automatically. Turn the wheel Left/Right to un-mute the audio, input audio LED indicator will illuminate to the last selection.

## 6.2 Rear Panel

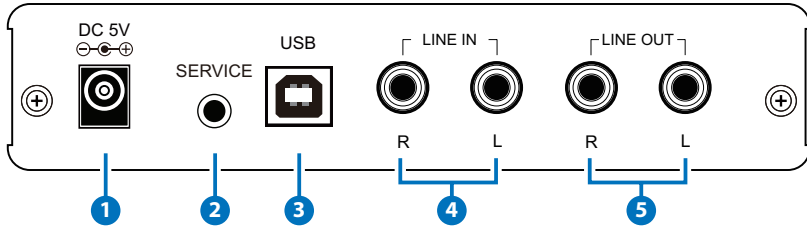

### 1 DC 5V:

Plug the 5V DC power supply into the unit and connect the adaptor to an AC outlet.

### 2 RS-232:

Connect 3.5mm D-Sub 9 pin adaptor cable to PC/Notebook for RS-232 control.

### 3 USB IN:

Connect to a PC/MAC source for USB audio signal input or firmware update.

### 4 Line IN:

Connect the L/R IN to an analog stereo input source such as CD player or media player.

### 5 Line OUT:

Connect the L/R OUT to amplifier or active speakers with RCA jack cables.

## 7. RS-232 CONTROL

### 7.1 RS-232 Protocol

HA-U1	
PIN	Assignment
1	NC
2	Tx
3	Rx
4	NC
5	GND
6	NC
7	NC
8	NC
9	NC



Remote Control	
PIN	Assignment
1	NC
2	Rx
3	Tx
4	NC
5	GND
6	NC
7	NC
8	NC
9	NC

Baud Rate: 19200 bps

Data bit: 8-bits

Parity: None

Stop Bit: 1

## 7.2 RS-232 Command

Command	Description
PORT 00	Switch Front In
PORT 01	Switch Line In
PORT 02	Switch USB In
VOL 00	Volume controller
VOL -(01---160)	Volume controller
POWER 00	Power off
POWER 01	Power on
MUTE 00	Mute off
MUTE 01	Mute on
FIX 00	LINE Out volume levels
FIX 01	LINE Out fix level
ME 03	Reset to default
HPR (00---05)	HPR 00: 16Ω HPR 01: 32Ω HPR 02: 64Ω HPR 03: 200Ω HPR 04: 300Ω HPR 05: 600Ω



?	<p>Display all available commands</p> <p>Ext:</p> <p>Support UART commands as list</p> <p>commands : Description</p> <p>PORT 00: Front In</p> <p>PORT 01: Line In</p> <p>PORT 02: USB In</p> <p>POWER 00: POWER OFF</p> <p>POWER 01: POWER ON</p> <p>MUTE 00: MUTE OFF</p> <p>MUTE 01: MUTE ON</p> <p>FIX 00: FIX OFF</p> <p>FIX 01: FIX ON</p> <p>HPR 00: 16_OHM</p> <p>HPR 01: 32_OHM</p> <p>HPR 02: 64_OHM</p> <p>HPR 03: 200_OHM</p> <p>HPR 04: 300_OHM</p> <p>HPR 05: 600_OHM</p> <p>VOL 00: VOL xxdB</p> <p>VOL -(01---160): VOL -xxdB</p> <p>ME 03: Reset to default</p> <p>INFO : Display the current status and F/W version</p> <p>?: Display all available commands</p>
INFO	Display the current status and F/W version

## 8. CONNECTION DIAGRAM

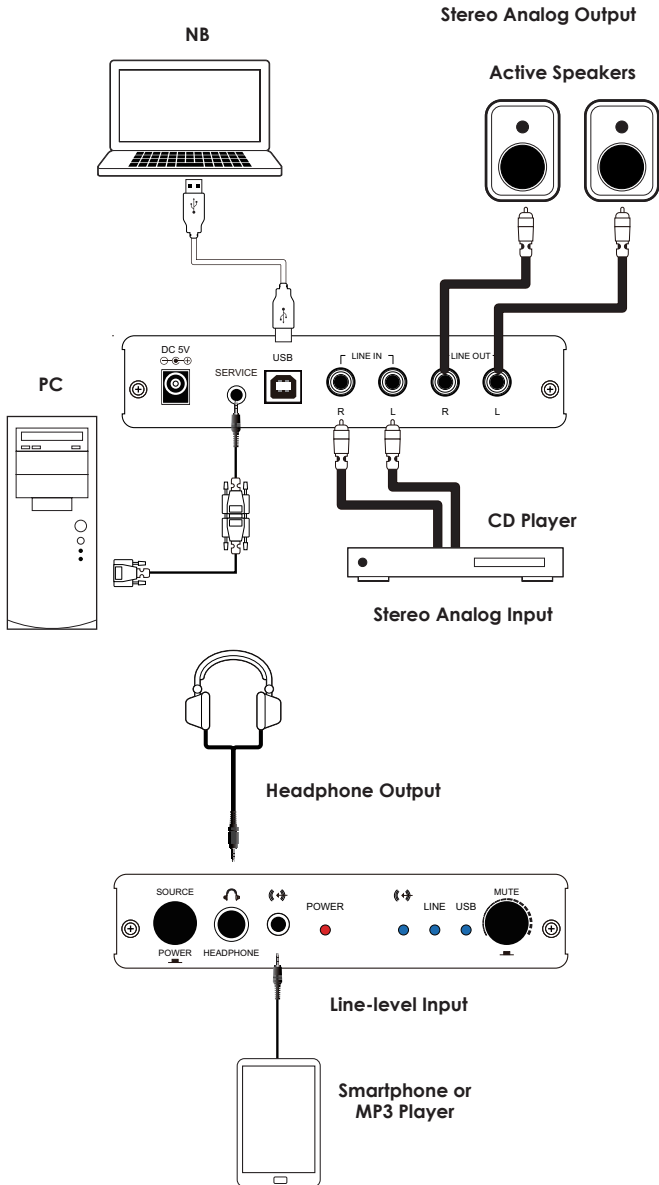

## 9. SPECIFICATIONS

<b>Input port</b>	1 x 3.5Ø Line in, 1 x R/L RCA, 1 x USB (Type B), 1 x 3.5mm 9pin (RS-232),
<b>Output port</b>	1 x L/R (Analog Stereo 2RCA), 1 x 6.3mm Headphone
<b>Audio Input/Output</b>	LPCM 2CH
<b>Stereo Input/Output Level</b>	2 Vrms ± 0.2
<b>ESD Protection</b>	Human body model: ±8kV (air-gap discharge) ±4kV (contact discharge)
<b>Power Supply</b>	5V/ 2.6A DC (US/EU standards, CE/FCC/UL certified)
<b>Dimensions</b>	145mm(W) x 113mm(D) x 30mm(H)
<b>Weight</b>	g
<b>Chassis Material</b>	Aluminum
<b>Silkscreen Color</b>	Black
<b>Operating Temperature</b>	0°C ~ 40°C
<b>Storage Temperature</b>	-20°C ~ 60°C / -4 °F ~ 140 °F
<b>Relative Humidity</b>	20 ~ 90% RH (non-condensing)
<b>Power Consumption</b>	8.5W