

OPERATION MANUAL

TH2819A

Precision LCR Meter

Manual Printing History

The manual printing data and part number indicate its current edition. The printing date changes when a new edition is printed. The manual part number changes when extensive technical changes are incorporated.

November 2007 First Edition

Notice

The information contained in this document is subject to change without notice.

Caution



Do not exceed the operating input voltage, and current level and signal type appropriate for the instrument being used, refer to your instrument's Function Reference.



Electrostatic discharge (ESD) can damage the highly sensitive microcircuits in your instrument. ESD damage is most likely to occur as the test fixtures are being connected or disconnected. Protect them from ESD damage by wearing a grounding strap that provides a high resistance path to ground. Alternatively, ground yourself to discharge any static charge built-up by touching the outer shell of any grounded instrument chassis before touching the test port connectors.

Safety Summary

When you notice any of the unusual conditions listed below, immediately terminate operation and disconnect the power lead.

Contact your local Tonghui sales representative or authorized service company for repair of the instrument. If you continue to operate without repairing the instrument, there is a potential fire or shock hazard for the operator.

- Instrument operates abnormally.
- Instrument emits abnormal noise, smell, smoke or a spark-like light during operation.
- Instrument generates high temperature or electrical shock during operation.
- Power lead, plug, or receptacle on instrument is damaged.
- Foreign substance or liquid has fallen into the instrument.

Safety notice supplement

This equipment is MEASUREMENT CATEGORY I (CAT I). Do not use for CAT II, III, or IV.

This equipment is POLLUTION DEGREE 2, INDOOR USE product.

Contents

| | |
|---|----|
| Chapter 1 Unpacking | 10 |
| 1.1 Checking the Shipment | 10 |
| 1.2 Product Introduction | 10 |
| 1.3 Power connection | 11 |
| 1.4 The Fuse | 11 |
| 1.5 Operating Environment | 11 |
| 1.6 Test fixture | 12 |
| 1.7 Preheating | 12 |
| 1.8 Other features | 12 |
| Chapter 2 Panel description and basic operation | 13 |
| 2.1 Front Panel | 13 |
| 2.2 Rear Panel | 15 |
| 2.3 Display Area Definition | 16 |
| 2.4 Menu keys and Display Page | 17 |
| 2.4.1 LCRZ Menu key | 17 |
| 2.4.2 SYSTEM Menu key | 17 |
| 2.5 Basic Operation | 18 |
| Chapter 3 [LCRZ] menu key description | 23 |
| 3.1 Welcome Page | 23 |
| 3.2 LCRZ Menu | 23 |
| 3.2.1 LCR MEAS DISP page | 23 |
| 3.2.2 Measurement Function | 25 |
| 3.2.3 Measurement Range | 28 |
| 3.2.4 Test Frequency | 28 |
| 3.2.5 Oscillator Level | 30 |
| 3.2.6 DC Bias | 31 |
| 3.2.7 Measurement Speed | 31 |
| 3.2.8 File Manage | 32 |
| 3.2.9 Useful Tools | 35 |
| 3.3 BIN No. DISP page | 35 |
| 3.3.1 Comparator Function ON/OFF Description | 37 |
| 3.3.2 File Manage | 38 |
| 3.3.3 Useful Tools | 38 |
| 3.4 BIN COUNT DISP page | 38 |
| 3.4.1 File Manage | 39 |
| 3.4.2 Useful Tools | 40 |
| 3.5 LIST SWEEP DISP Page | 40 |
| 3.5.1 File Manage | 42 |
| 3.5.2 Useful Tools | 42 |
| 3.6 MEAS SETUP Page | 42 |

| | | |
|---|--|----|
| 3.6.1 | Trigger Mode | 46 |
| 3.6.2 | Automatic Level Control Function | 47 |
| 3.6.3 | Bias Current Isolation Function | 48 |
| 3.6.4 | Averaging Rate | 49 |
| 3.6.5 | Level Monitor Function | 49 |
| 3.6.6 | Delay Time | 50 |
| 3.6.7 | Internal Resistance | 50 |
| 3.6.8 | Deviation Measurement Functions | 51 |
| 3.6.9 | File Manage | 52 |
| 3.6.10 | Useful Tools | 52 |
| 3.7 | CORRECTION Page | 52 |
| 3.7.1 | OPEN Correction | 55 |
| 3.7.2 | SHORT Correction | 57 |
| 3.7.3 | LOAD Correction | 59 |
| 3.7.4 | Measurement Function for the LOAD Correction | 61 |
| 3.7.5 | Cable Length Selection | 61 |
| 3.7.6 | Multi/Single Correction Mode Selection | 61 |
| 3.7.7 | File Manage | 61 |
| 3.7.8 | Useful Tools | 62 |
| 3.8 | LIMIT TABLE SETUP Page | 62 |
| 3.8.1 | Swap Parameter | 64 |
| 3.8.2 | Limit Mode for Comparator | 65 |
| 3.8.3 | Nominal Value for Tolerance Mode | 66 |
| 3.8.4 | Comparator Function ON/OFF | 66 |
| 3.8.5 | Auxiliary Bin ON/OFF | 67 |
| 3.8.6 | Low/High Limits | 68 |
| 3.8.7 | File Manage | 69 |
| 3.8.8 | Useful Tools | 69 |
| 3.9 | LIST SWEEP SETUP page | 69 |
| 3.9.1 | Sweep Mode | 71 |
| 3.9.2 | List Sweep Parameter | 72 |
| 3.9.3 | Sweep Points and Limit Mode | 72 |
| 3.9.4 | File Manage | 73 |
| 3.9.5 | Useful Tools | 73 |
| Chapter 4 [SYSTEM] menu key description | | 74 |
| 4.1 | SYSTEM Menu | 74 |
| 4.2 | SYSTEM SETUP Page | 74 |
| 4.2.1 | LCD Contrast adjustment | 76 |
| 4.2.2 | BEEPER | 76 |
| 4.2.3 | Pass beep | 77 |
| 4.2.4 | FAIL BEEP | 77 |
| 4.2.5 | LANGUAGE selection | 78 |
| 4.2.6 | PASS WORD function | 78 |
| 4.2.7 | BUS MODE selection | 79 |

| | | |
|--|---|----|
| 4.2.8 | BUS Address setup | 79 |
| 4.2.9 | Talk only mode ON/OFF | 80 |
| 4.2.10 | DC Bias Source mode..... | 80 |
| 4.2.11 | BAUD RATE..... | 80 |
| 4.2.12 | File Manage | 81 |
| 4.2.13 | Useful Tools..... | 81 |
| Chapter 5 Measurement procedure and examples | | 82 |
| 5.1 | Clear (CORRECTION OPERATION) | 82 |
| 5.1.1 | Frequency sweep clear | 82 |
| 5.1.2 | Dot frequency clear (for single frequency)..... | 83 |
| 5.2 | The right connection between the test fixture and the DUT | 83 |
| 5.3 | Eliminate the disturbance of the stray capacitance | 84 |
| 5.4 | Inductance test example | 85 |
| 5.5 | Multi-frequency List sweep for capacitance test..... | 87 |
| 5.6 | Operation example for load correction..... | 89 |
| Chapter 6 Performance and measurement | | 91 |
| 6.1 | Measurement function..... | 91 |
| 6.1.1 | Measurement parameter and sign description..... | 91 |
| 6.1.2 | Test combination..... | 91 |
| 6.1.3 | Math operation..... | 91 |
| 6.1.4 | Equivalent mode | 91 |
| 6.1.5 | Range | 92 |
| 6.1.6 | Trigger | 92 |
| 6.1.7 | Delay time..... | 92 |
| 6.1.8 | The unknown terminal | 92 |
| 6.1.9 | Measurement speed..... | 92 |
| 6.1.10 | Average..... | 92 |
| 6.1.11 | Display digits..... | 92 |
| 6.2 | Test signal | 93 |
| 6.2.1 | Test signal frequency | 93 |
| 6.2.2 | Signal mode | 93 |
| 6.2.3 | The test signal level | 93 |
| 6.2.4 | The output impedance..... | 93 |
| 6.2.5 | The monitor for test signal level | 93 |
| 6.2.6 | The maximum range of the test and display | 94 |
| 6.2.7 | The test voltage for DC resistance | 94 |
| 6.2.8 | The internal DC voltage bias | 94 |
| 6.3 | The test accuracy..... | 94 |
| 6.3.1 | The accuracy of $ Z $ 、 $ Y $ 、L、C、R、X、G、B..... | 94 |
| 6.3.2 | The D accuracy | 95 |
| 6.3.3 | The Q accuracy | 95 |
| 6.3.4 | The θ accuracy | 95 |
| 6.3.5 | the G accuracy | 95 |

| | | |
|-----------|---|-----|
| 6.3.6 | The Rp accuracy | 96 |
| 6.3.7 | The Rs accuracy..... | 96 |
| 6.3.8 | The accuracy factor..... | 96 |
| 6.3.9 | The DCR accuracy..... | 99 |
| 6.3.10 | The Lk accuracy | 99 |
| 6.3.11 | The Turns Ratio accuracy | 100 |
| 6.4 | Safety requirement..... | 100 |
| 6.4.1 | insulation resistance..... | 100 |
| 6.4.2 | insulation intension..... | 100 |
| 6.4.3 | Leakage current..... | 100 |
| 6.5 | The EMC requirement | 100 |
| 6.6 | Performance test..... | 100 |
| 6.6.1 | Working condition | 100 |
| 6.6.2 | The experiment instruments..... | 100 |
| 6.6.3 | Check the Function | 101 |
| 6.6.4 | The test signal level | 101 |
| 6.6.5 | frequency | 102 |
| 6.6.6 | The test accuracy | 102 |
| 6.6.7 | The capacitance C and the loss D accuracy | 102 |
| 6.6.8 | The inductance L accuracy | 102 |
| 6.6.9 | The resistance Z accuracy..... | 102 |
| 6.6.10 | The DCR accuracy..... | 103 |
| Chapter 7 | Remote control..... | 104 |
| 7.1 | TH2819A RS232C interface | 104 |
| 7.2 | TH2819A GPIB(optional)..... | 105 |
| 7.2.1 | GPIB interface function..... | 107 |
| 7.2.2 | GPIB address | 108 |
| 7.2.3 | GPIB bus function | 108 |
| 7.2.4 | SCPI..... | 108 |
| Chapter 8 | TH2819A commands | 110 |
| 8.1 | Subsystem commands for TH2819A | 110 |
| 8.1.1 | DISPlay subsystem command set..... | 110 |
| 8.1.2 | FREQuency subsystem command set..... | 112 |
| 8.1.3 | VOLTage subsystem command set | 112 |
| 8.1.4 | CURRent subsystem command set..... | 113 |
| 8.1.5 | AMPLitude subsystem command set..... | 113 |
| 8.1.6 | Output RESister subsystem command set | 114 |
| 8.1.7 | OUTPut subsystem command set | 114 |
| 8.1.8 | BIAS subsystem command set..... | 115 |
| 8.1.9 | FUNcTION subsystem command set..... | 116 |
| 8.1.10 | LIST subsystem command set..... | 121 |
| 8.1.11 | APERture subsystem command set..... | 124 |
| 8.1.12 | TRIGger subsystem command set..... | 124 |

| | | |
|---|--|-----|
| 8.1.13 | FETCh? subsystem command set | 126 |
| 8.1.14 | CORRection subsystem command set | 128 |
| 8.1.15 | COMParator subsystem command set | 134 |
| 8.1.16 | Mass MEMory subsystem command set | 138 |
| 8.2 | The GPIB common command for TH2819A | 139 |
| Chapter 9 The description for Handler (optional)..... | | 142 |
| 9.1 | The technology description for TH2819A Handler | 142 |
| 9.2 | The operation description..... | 142 |
| 9.2.1 | The definition for the signal line..... | 142 |
| 9.2.2 | Electrical feature | 150 |
| 9.2.3 | HANDLER Interface board circuit | 151 |
| 9.2.4 | operation | 154 |

Chapter 1 Unpacking

Thank you for choosing the product of our company.

This chapter describes how to start the TH2819A Precision LCR Meter.

The main contents in this chapter are below:

- Checking the shipment
After you receive the TH2819A, check all the items in the packing container.
- Preparations before using the instrument
Shows how to check the power as well as check and connect the power lead.
- Environmental Requirements
Describes the system requirements needed to install the TH2819A.

1.1 Checking the Shipment

After you receive the TH2819A, please check whether the content is complete. The contents of the shipment are listed below. If the contents are incomplete, if there is mechanical damage or defect, or if the instrument does not pass the power-on self tests, please notify our company.

Items packed with TH2819A:

| No. | Description | Quantity |
|-----|----------------------------------|----------|
| 1 | TH2819A Precision LCR Meter | 1 |
| 2 | TH26011 Kelvin test lead | 1 |
| 3 | TH26005-1 test fixture | 1 |
| 4 | TH26004B test lead | 1 |
| 5 | 3-p power lead | 1 |
| 6 | 2A fuse | 2 |
| 7 | Operation manual | 1 |
| 8 | Quality and warranty certificate | 1 |
| 9 | Test report | 1 |

Note: Read the operation manual clearly before operating the instrument, or operate under the guidance of technician to avoid unnecessary question.

1.2 Product Introduction

TH2819A is a Precision LCR Meter. It is an updated product of TH2819 LCR meter with the features of TH2819, including easy operation, accurate and stable reading. It has smaller size, nicer appearance,

and lower cost than TH2819, With test frequency from 20Hz to 200kHz, frequency resolution of 10mHz, wide test signal level range from 5mV to 2V, measurement speed up to 32ms/time, TH2819A can be used to inspect electronic components, not only for measurement parameters that TH2819 has, but also for DCR measurement. With high speed, wide test range, and 6-digit resolution, the meter has 1.5V/2V internal bias voltage, optional $\pm 10V$ ($\pm 100mA$) and 1A internal DC bias source and external inductance bias sources to inspect inductive components.

TH2819A can be used in quality control on production line, incoming inspection and lab measurement.

1.3 Power connection

Confirm that the power supplied to the TH2819A meets the following requirements:

- (1) The voltage range: 100 ~120 VAC or 198 ~242 VAC. It is related to the power setting on the back panel.
- (2) The frequency range: 47 ~63 Hz.
- (3) The power consumption range: $\geq 80VA$.
- (4) The L-line, the N-line and the E-line of the input power must be homologous to the lines of the instrument power.
- (5) The instrument should be used in low noise environment, although it has been designed carefully to decrease the noise disturbance caused by the AC power. If you can't avoid using the instrument in high noise environment, please install the power filter.

Note: To avoid the damage to the instrument and yourself, which is caused by the leakage current, you should ensure that the ground line of the power is connected to the ground reliably.

1.4 The Fuse

The fuse has been set up before shipping, you should use the fuse prepared by Tonghui Company or the one with the same type. To verify and replace the fuse, remove the power lead and pull out the fuse holder.

1.5 Operating Environment

The instrument must be operated under the following environment conditions:

- (1) Please don't use the instrument under the conditions below: more dust, more shock, exposing in the sunlight, or more corrosive gas.
- (2) Temperature: 0 °C to 40 °C, Humidity: $\leq 95\%R.H.$ at 40 °C
- (3) Sufficient space must be kept behind the instrument to avoid obstructing the air flow of the cooling fans.
- (4) The instrument should be used in low noise environment, although it has been designed carefully to

decrease the noise disturbance caused by the AC power. If you can't avoid using the instrument in high noise environment, please install the power filter.

(5) If the instrument will not be used for a long time, please store the instrument under the conditions below: Temperature: 5°C to 40°C, Humidity: ≤85%R.H. at 40°C, Less corrosive gas, and not exposing in the sunlight.

(6) The instrument, especially the test leads, must keep away from the intense electromagnetic field to avoid the disturbance to the test.

1.6 Test fixture

Please use the test fixture or the test leads prepared for you by Tonghui Company. If you use the one made by yourself or other companies, the wrong result will occur. You must keep the test fixture, the test leads and the pins of the DUT cleanly, so that the test device can contact the test fixture close.

Connect the test fixture or the test leads to the four test terminals (Hcur、Hpot、Lcur、Lpot) on the front panel. If the DUT with shielded enclosure is tested, connect the shielded layer to the instrument ground “⊥”.

Note: the precarious result will occur when the test fixture or the test leads is not stalled.

1.7 Preheating

(1) To acquire the exact result, the preheating time after turning on the power must be not less than 15 minutes.

(2) Please do not turn on and turn off the power continually, or the inner data will be confused.

1.8 Other features

(1) Power consumption: ≤80VA;

(2) Dimensions (W*H*D): 400mm*135mm*427mm;

(3) Weight: Approximately 10kg

Chapter 2 Panel description and basic operation

This chapter provides information on the panel and the menu keys of the TH2819A. It also offers the basic operation for TH2819A.

2.1 Front Panel

Figure 2-1 shows the brief description of the TH2819A's front panel.

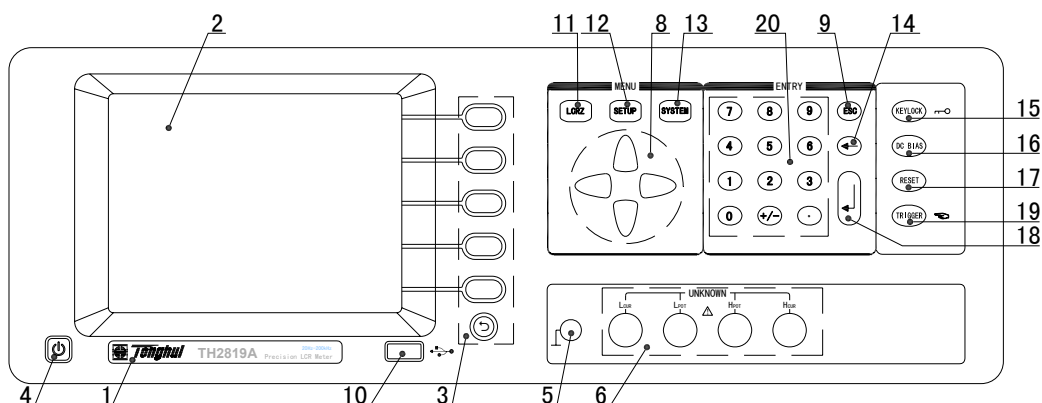

Figure 2-1 the front panel

(1) Brand and Name

The registered brand of our company and name of the instrument are printed.

(2) LCD

320*240 dot-matrix Liquid Crystal Display (LCD) displays measurement results, test conditions, etc.

(3) SOFTKEYS

Six softkeys are used to select control and parameter functions. Each softkey has a softkey label along its left side. The softkey label changes when the display page changes.

The function of the round softkey is below:

When the corresponding softkey area on the screen page displays "more", the function of the key is "page up". When the corresponding softkey area on the screen page displays "Escape", the function of the key is to escape the current page.

(4) Power on/off

Power on/off switch. In "ON" position, all operating voltages are applied to the instrument. In the "OFF" position, no operating voltages are applied to the instrument.

(5)FRAME Terminal

This is the FRAME Terminal which is tied to the instrument's chassis and which can be used for measurements that require guarding.

(6)UNKNOWN Terminals

These are the UNKNOWN Terminals used to connect a four-terminal pair test fixture or test leads for measuring the device under test.

HD: High current drive

HS: High potential sense

LS: Low potential sense

LD: Low current drive

(8) CURSOR Keys

The CURSOR keys are used to move the field from one field to another field on the LCD display page. When the cursor is moved to a field, the field changes to an inverse video image of the original field.

(9) ESC

ESCAPE key

(10) USB Interface

The USB interface is used to connect with USB disk.

(11) **LCRZ** menu key

The pages in menu key **LCRZ** are used for displaying the LCRZ measurement results, and measurement setup. When **LCRZ** is pressed, the LCR MEAS DISP page will be displayed on the LCD screen. The cursor will be positioned at the LCR MEAS DISP field. The power-on default display page is the LCR MEAS DISP page.

(12) **SETUP** menu key

The pages in menu key **SETUP** are used for setting the LCRZ measurement parameters and displaying the transformer measurement results. When **SETUP** is pressed, the LCR TEST SET page will be displayed on the LCD screen. The cursor will be positioned at the LCR TEST set field.

(13) **SYSTEM** menu key

The pages in menu key **SYSTEM** are used for operating conditions other than main measurement control. When **SYSTEM** is pressed, the SYSTEM SETUP page will be displayed.

(14) key

 key deletes one last character of the input value.

(15) **KEYLOCK** key

KEYLOCK key is used to lock and unlock the keyboard. When the key is pressed, the system information line at the bottom of LCD will display "Keys locked" which means that the keys except **KEYLOCK** on the front panel are locked. And you can press **KEYLOCK** key again to unlock the keys. (The correct pass word must be input, if the keyboard is locked with a pass word.)

(16) **DC BIAS** key

The **DC BIAS** key is used to enable the DC bias output. The DC BIAS ON/OFF information and

indicator are displayed in the system information line. When DC BIAS is set to ON, the DC BIAS ON/OFF indicator is ON, “! Bias turn on” is displayed. When DC BIAS is set to OFF, the DC BIAS ON/OFF indicator is OFF. “! Bias turn off” is displayed. If DC BIAS is set to OFF, even though the DC bias is set to ON according to the BIAS display field, the DC bias isn't output.

(17) **RESET** key

The key is used to stop the current transformer measurement and cut off the high voltage output in the transformer test system.

(18) **ENTER** key

ENTER terminates numeric input data and enters the displayed value on the system information (bottom line of the LCD screen).

(19) **TRIGGER** key

This is the **TRIGGER** key used to manually trigger the TH2819A when it is set to the Manual Trigger mode.

(20) **NUMBER** keys

The **NUMBER** keys are composed of the digits **0** to **9**, a period **.**, a minus sign **-**, keys are used to enter numeric data into the TH2819A.

2.2 Rear Panel

Figure 2-2 shows the brief description of the TH2819A's rear panel.

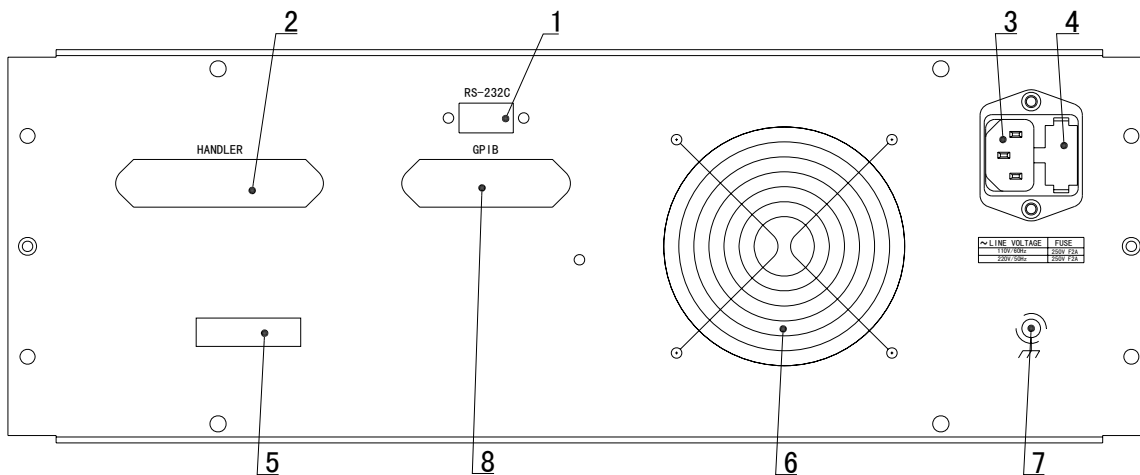

Figure 2-2 the rear pane

(1)RS232C Interface Connector

This is the RS232C interface connector used when operating on the serial interface is used.

(2)HANDLER Interface Connector (Optional)

This is the HANDLER interface connector used when you perform the operation with a component handler to fully automate component testing, sorting, and quality control data processing.

(3)LINE Input Receptacle

AC power receptacle.

(4) Fuse Holder

Fuse holder for TH2819A fuse, 220Vac, 2A.

(5) Name Plate

Name Plate is used to provide the information of date, model and manufacturer etc.

(6) Window of Cooling Fan

This window is used to provide a way for the air flow of the cooling fan.

(7) FRAME Terminal

This is the FRAME Terminal which is tied to the instrument's chassis and which can be used for measurements that require guarding.

(8)GPIO interface

General Purpose Interface Bus (GPIB). The connection of an external controller and other devices through this connector allows you to configure an automatic measurement system.

2.3 Display Area Definition

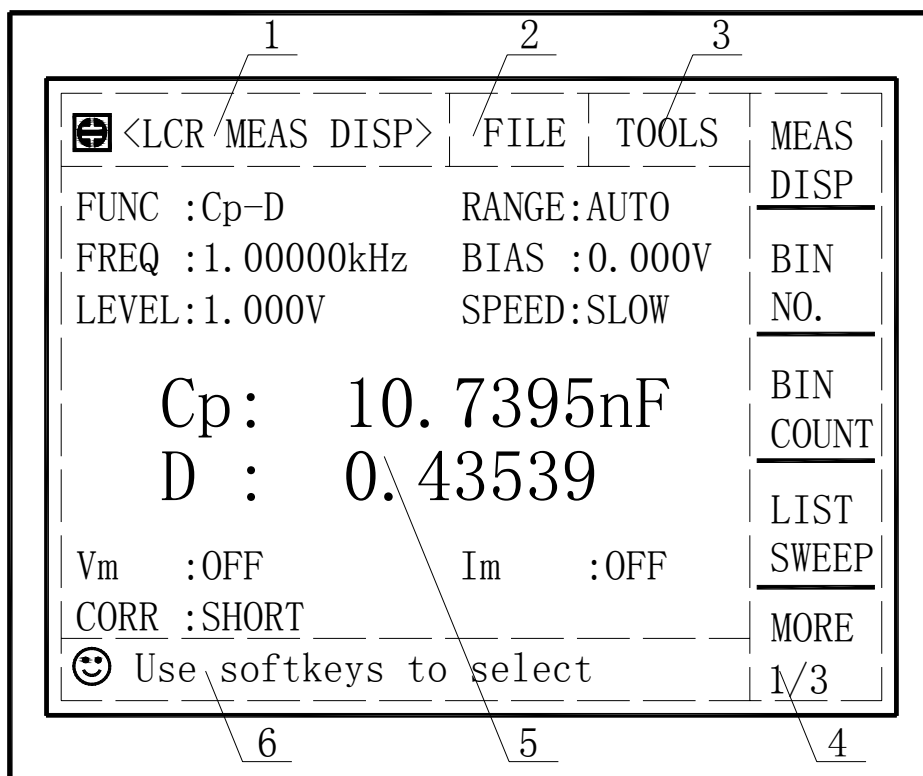

Figure 2-3 the display area

① Display Page Area

This is the display page area. This area identifies the current display page.

② File Field

When the cursor is set on the FILE field, FILE Manage function is available, Select FILE Manage function, common file functions which are not displayed on the display pages (for example, LOAD/STORE/DEL

function) are made available.

③ TOOLS Field

Some special controls which cannot be set on a display page's fields are made available.

④ Softkey Area

The last six character positions of each line are reserved for softkey labels. The softkeys displayed correspond to the field at the cursor's position on the LCD.

⑤ Measurement Data/Conditions Area

This area is where measurement results and measurement conditions are displayed.

⑥ Input Line and System Information Line

This line is where system message, comments, error messages and numeric input data are displayed

2.4 Menu keys and Display Page

2.4.1 LCRZ Menu key

Press the key LCRZ, the following items will be displayed in the softkey area:

- LCR MEAS DISP
- BIN No. DISP
- BIN COUNT DISP
- LIST SWEEP DISP

- MEAS SETUP
- CORRECTION
- LIMIT TABLE SETUP
- LIST SETUP

The first group of four display pages is used for displaying the measurement results, and displaying the sorting results.

The second group of four display pages is used for setting the measurement conditions (including the correction function), or setting the bin sorting limits.

2.4.2 SYSTEM Menu key

This menu has the following page

- SYSTEM SETUP

The page is used for operating conditions other than main measurement control.

| |
|-------|
| Title |
| Size |
| B |
| Date: |
| File: |

2.5 Basic Operation

The basic operation for TH2819A is described in the following paragraphs.

(1) Display the desired display page using both the MENU keys and the softkeys. (Refer to [Figure 2-4](#))

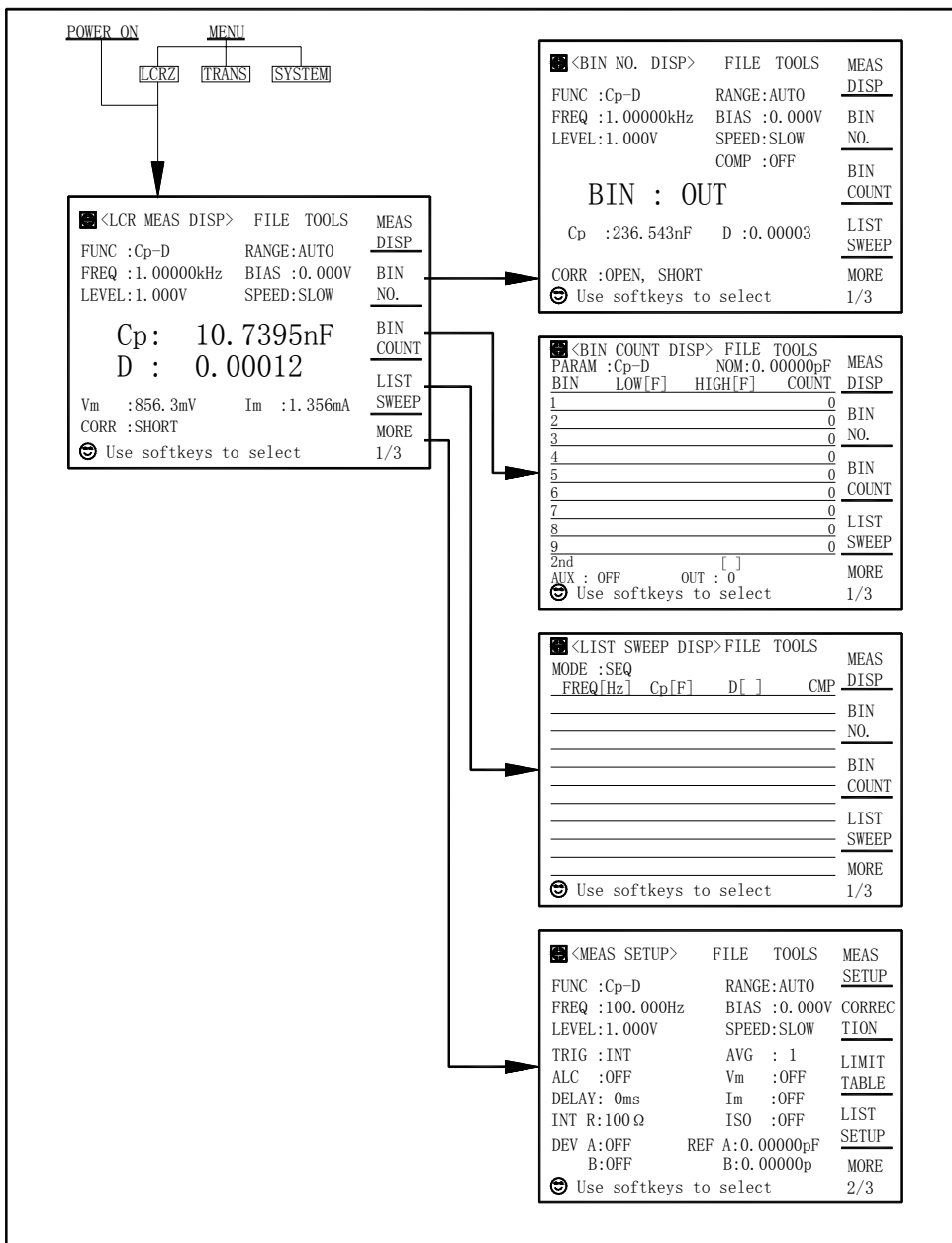

Figure 2-4 Display Pages (1/5)

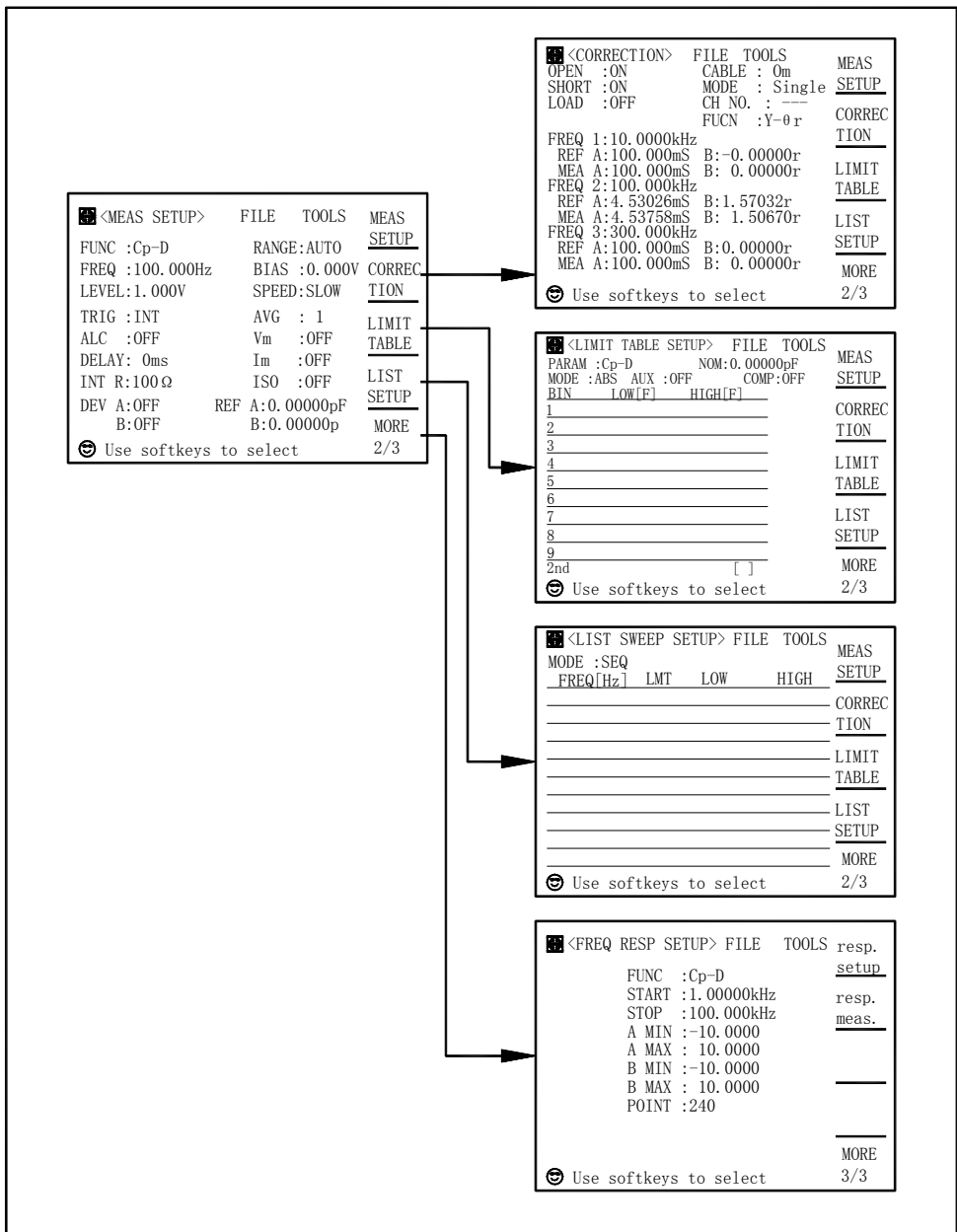

Figure 2-4 Display Pages (2/5)

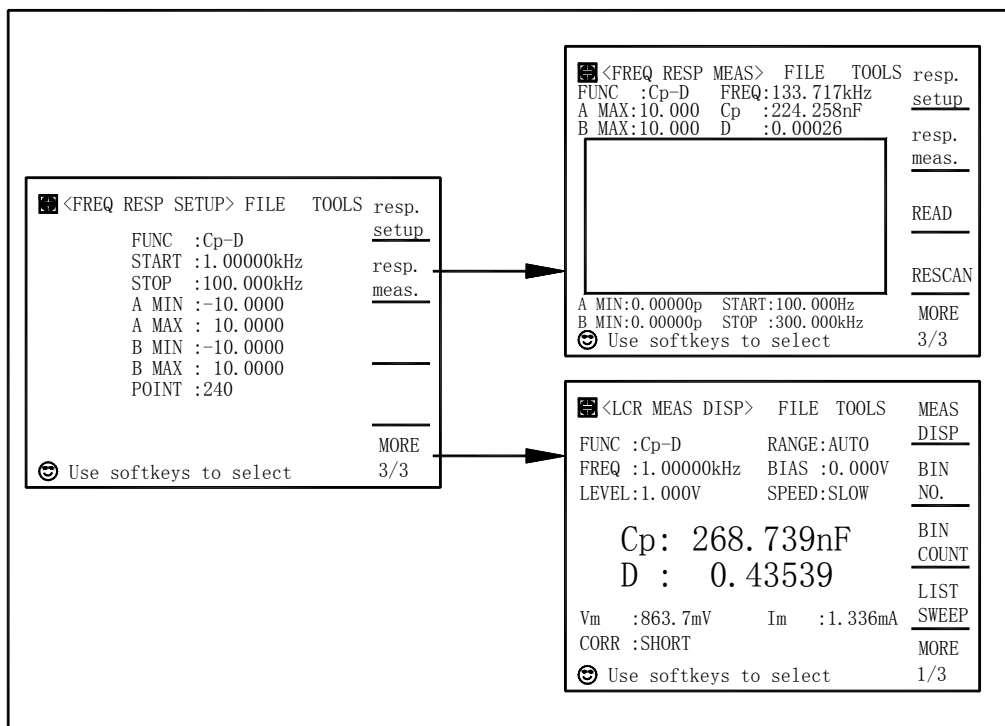

Figure 2-4 Display Pages (3/5)

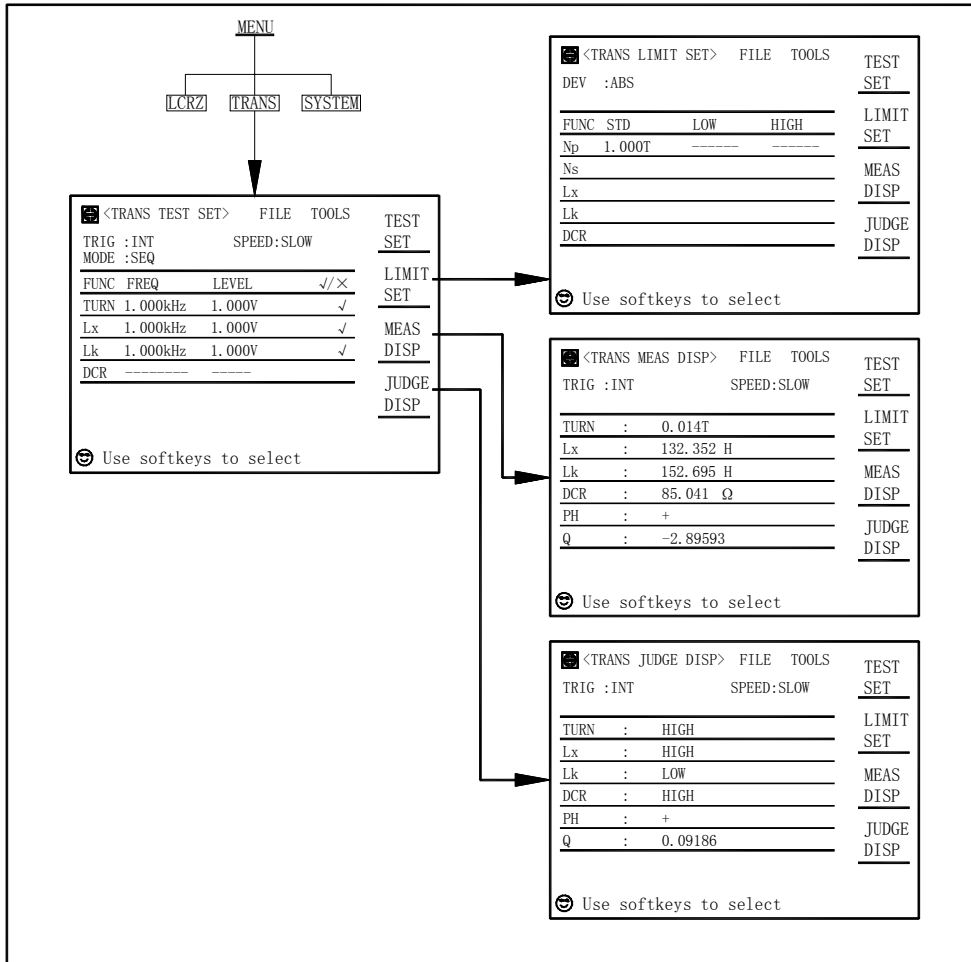

Figure 2-4 Display Pages (4/5)

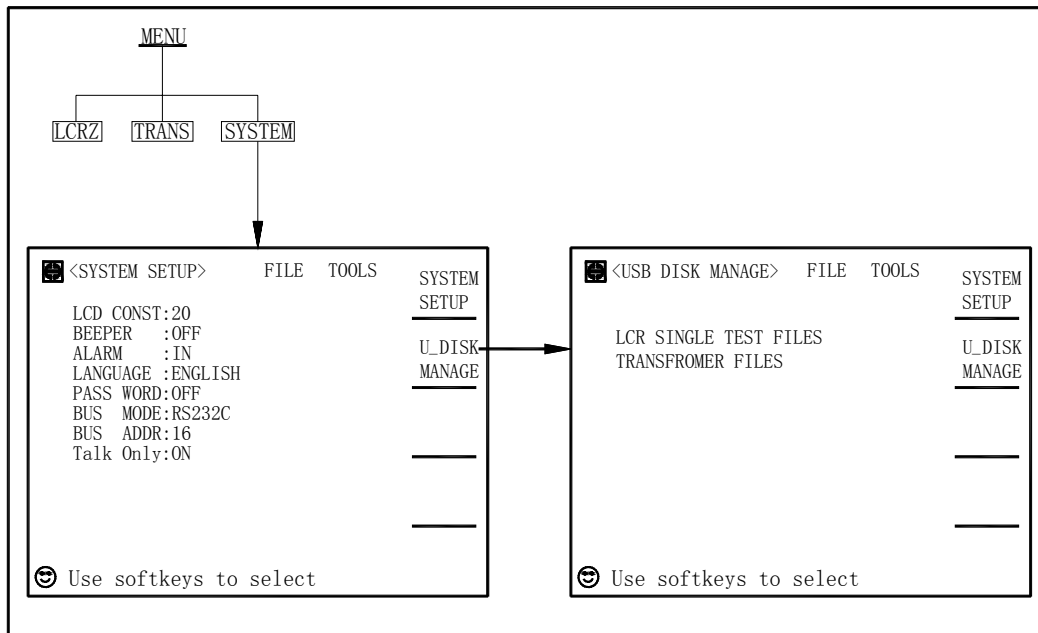

Figure 2-4 Display Pages (5/5)

(2) Move the cursor to the desired field using the cursor keys. When the cursor is moved to a field, the field changes to an inverse video image of the original field, and the field is the area where you can set the cursor.

(3) The softkeys corresponding to the field will be displayed. Select and press a softkey. The numeric entry keys and **ENTER** are used to enter numeric data. When one of the numeric entry keys is pressed, the softkeys will be changed to the available unit softkeys. You can use these unit softkeys instead of **ENTER**. When **ENTER** is used, the numeric data is entered with Hz, V, or A as the default unit depending on the cursor field selected, e.g.: test frequency's unit will be Hz, etc.

Chapter 3 [LCRZ] menu key description

This chapter describes the [LCRZ] menu key. At the same time, the softkey function is offered for you.

3.1 Welcome Page

Press the power switch to turn on TH2819A, the welcome page will be displayed as shown in Figure 3-1. The name of the instrument with its version will also be displayed. If password function is ON, you must input the correct password to start the instrument.



Figure 3-1 Welcome Page

Note: The default password for TH2819A is “2819”. The password can be set to ON or OFF and can be modified by you on the SYSTEM SETUP page.

3.2 LCRZ Menu

3.2.1 LCR MEAS DISP page

When you press **[LCRZ]**, the LCR MEAS DISP page shown in figure 3-2 will be displayed. On this page, the measurement results are displayed in large characters, and the following measurement controls can be set from this page.

- Measurement Function (FUNC)
- Measurement Range (RANGE)
- Test Frequency (FREQ)

- Oscillator Level (LEVEL)
- DC Bias (BIAS)
- Measurement Speed (SPEED)
- File Manage (FILE)
- Useful Tools (TOOLS)

There are nine fields on this page: LCR MEAS DISPLAY, FUNC, RANGE, FREQ, LEVEL, BIAS, SPEED, FILE and TOOLS. Each control function is described in the following paragraphs.

This page also provides the following information in measurement data and condition area on the displayed page. These conditions can be set from the MEAS SETUP page or CORRECTION page.

- Oscillator Level Voltage/Current Monitor value (Vm, Im)
- OPEN, SHORT, LOAD on/off setting conditions (CORR)

The available fields and the softkeys which correspond to the fields on this page are shown in Figure 3-2 and Figure 3-3 respectively.

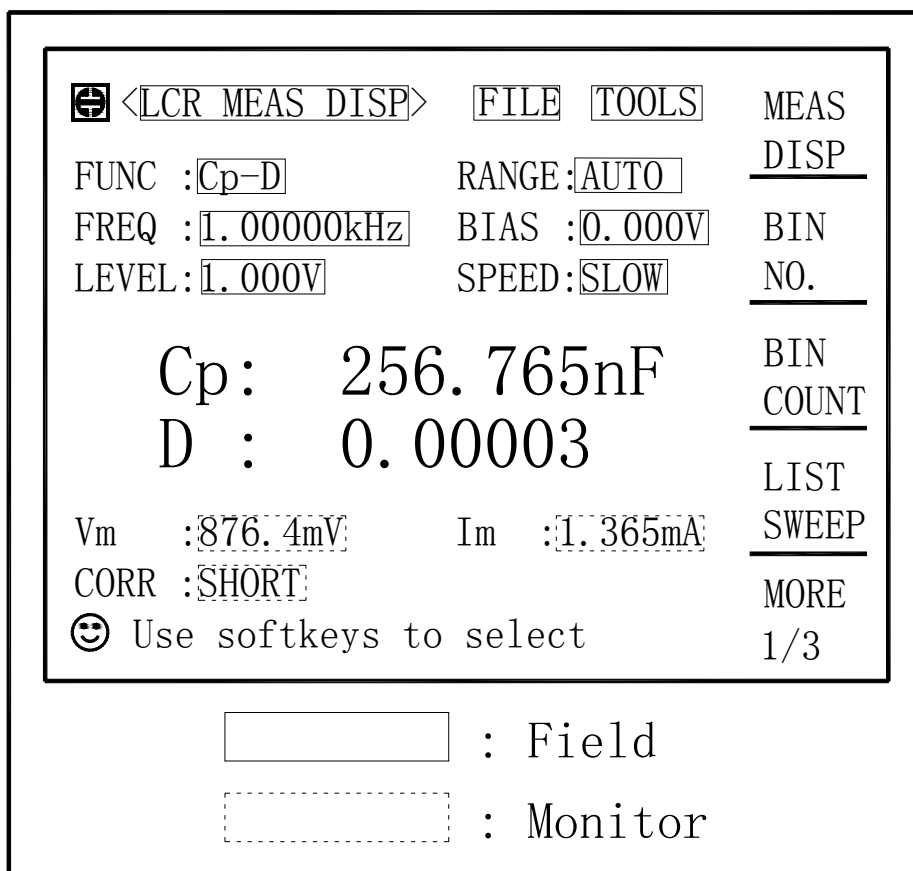

Figure 3-2 Available Fields on the LCR MEAS DISP Page

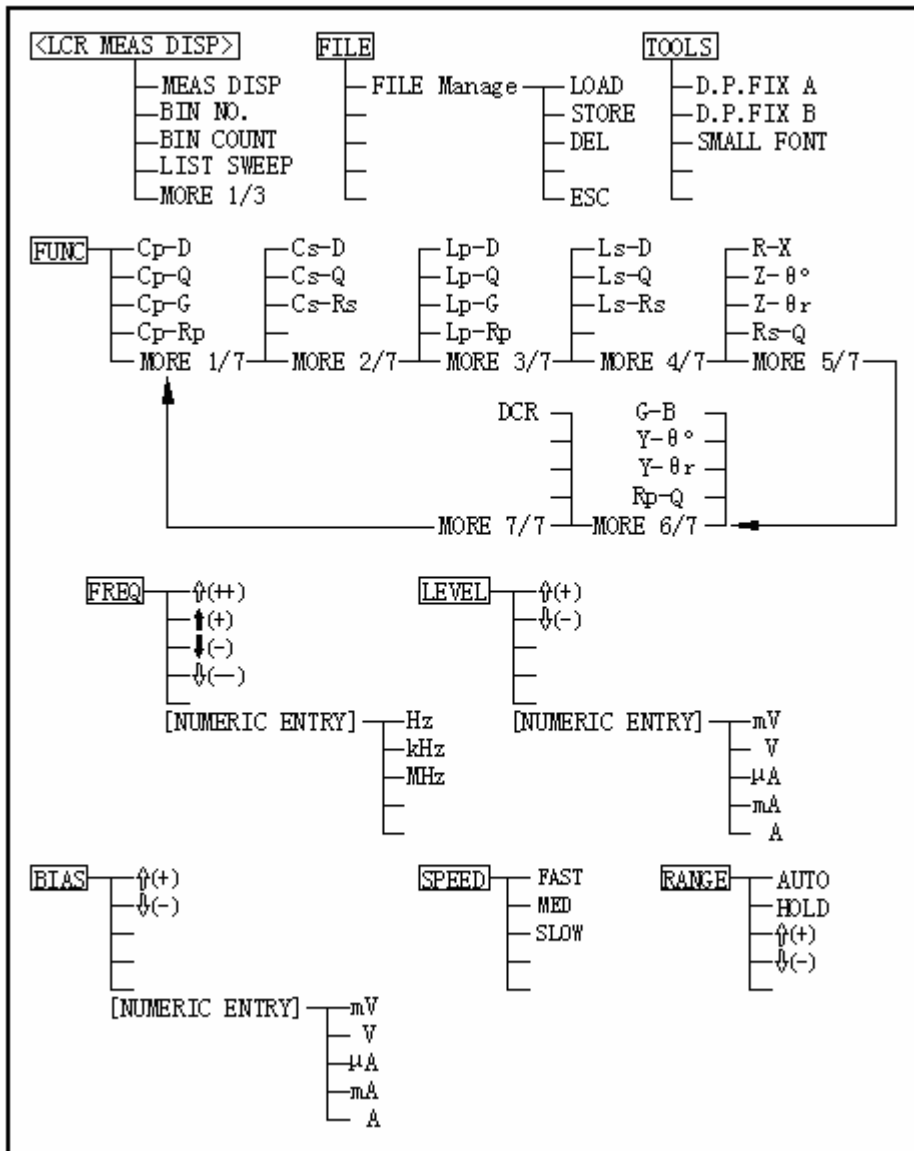

Figure 3-3 Available Softkeys on the LCR MEAS DISP Page

3.2.2 Measurement Function

TH2819A measures two components of the complex impedance (parameters) at the same time in a measurement cycle. The measurement parameters are listed as follows.

Primary Parameters

- |Z| (absolute value of impedance)
- |Y| (absolute value of admittance)
- L (inductance)
- C (capacitance)
- R (resistance)
- G (conductance)
- DCR(DC resistance)

Secondary Parameters

- D (dissipation factor)
- Q (quality factor)
- Rs (ESR (equivalent series resistance))
- Rp (equivalent parallel resistance)
- X (reactance)
- B (susceptance)
- Θ (phase angle)

The primary parameter of the measurement result is located on the upper line as two large character lines on this page, and the secondary parameter of the measurement result is located on the lower line as two large character lines on this page.

Front Panel Operation for Setting the Measurement Function

Perform the following steps to set the measurement function.

- 1) Use the CURSOR arrow keys to move the cursor to the FUNC field. The following softkeys will be displayed.
 - Cp-D
 - Cp-Q
 - Cp-G
 - Cp-Rp
 - MORE 1/7
- 2) Select and press a softkey to set the measurement function. If the softkey you want is not displayed, press MORE 1/7 to display the following set of softkeys.
 - Cs-D
 - Cs-Q
 - Cs-Rs
 - MORE 2/7
- 3) Select and press a softkey to set the measurement function. If the softkey you want is not

displayed, press **MORE 2/7** to display the following set of softkeys.

- Lp-D
- Lp-Q
- Lp-G
- Lp-Rp
- **MORE 3/7**

- 4) Select and press a softkey to set the measurement function. If the softkey you want is not displayed, press **MORE 3/7** to display the following set of softkeys.

- Ls-D
- Ls-Q
- Ls-Rs
- **MORE 4/7**

- 5) Select and press a softkey to set the measurement function. If the softkey you want is not displayed, press **MORE 4/7** to display the following set of softkeys.

- R-X
- Z- θ°
- Z- θ r
- Rs-Q
- **MORE 5/7**

- 6) Select and press a softkey to set the measurement function. If the softkey you want is not displayed, press **MORE 5/7** to display the following set of softkeys.

- G-B
- Y- θ°
- Y- θ r
- Rp-Q
- **MORE 6/7**

- 7) Select and press a softkey to set the measurement function. If the softkey you want is not displayed, press **MORE 6/7** to display the following set of softkeys.

- DCR
- **MORE 7/7**

- 8) Select and press a softkey to set the measurement function. When **MORE 7/7** is pressed, the softkeys shown in step 1 will be displayed. Retry steps 1 to 8 if you missed the function you were looking for.

3.2.3 Measurement Range

Th2819A has nine measurement ranges for AC measurement: 10Ω, 30Ω, 100Ω, 300Ω, 1kΩ, 3kΩ, 10kΩ, 30K and 100kΩ. It has ten measurement ranges for DC measurement: 100mΩ, 1Ω, 10Ω, 100Ω, 300Ω, 1kΩ, 3kΩ, 10kΩ, 30kΩ and 100kΩ. The measurement range is selected according to the DUT's impedance even if measurement parameter is capacitance or inductance.

Front Panel Operation for Setting the Measurement Range

Perform the following procedure to set the measurement range.

1) Move the cursor to the RANGE Field using the CURSOR keys. The following softkeys will be displayed.

- **AUTO** This softkey is used to set the measurement range to AUTO.
- **HOLD** This softkey is used to change the measurement range from the AUTO mode to the HOLD mode. When the measurement range is set to the HOLD mode, the impedance range is fixed at the current range setting, and the impedance range is displayed in the RANGE field.
- **↑(+)** This softkey is used to increase the measurement range in the HOLD (fixed range) mode.
- **↓(-)** This softkey is used to decrease the measurement range in the HOLD (fixed range) mode.

2) Use the softkeys to set the measurement range.

3.2.4 Test Frequency

TH2819A operates from 20 Hz to 300 kHz with 0.01 Hz resolution. When DCR measurement is selected for TH2819A, "----" is displayed in the frequency field.

Front Panel Operation for Setting the Test Frequency

There are two ways to set the test frequency. One is to use the softkeys, and the other is to use the numeric entry keys. Perform the following steps to set the test frequency.

1) Move the CURSOR to the FREQ field. The following softkeys will be displayed.

- **↑(++)**

This softkey is the coarse frequency increment softkey used to increase the test frequency to the

next sequential higher tenfold value after 20 Hz. The following frequency points can be set by using this softkey:

20 Hz 100 Hz 1 kHz 10 kHz 100 kHz 300 kHz

■ **↑(+)**

This softkey is the fine frequency increment softkey used to increase the current test frequency to the next sequential higher frequency point. There are 10 frequency points between the successive tenfold values. The sequential frequency points which can be set by using this softkey are as follows.

| | | | | |
|-------|--------|---------|--------|---------|
| 20 Hz | 100 Hz | 1 kHz | 10 kHz | 100 kHz |
| 25 Hz | 120 Hz | 1.2 kHz | 12 kHz | 120 kHz |
| 30 Hz | 150 Hz | 1.5 kHz | 15 kHz | 150 kHz |
| 40 Hz | 200 Hz | 2 kHz | 20 kHz | 200 kHz |
| 50 Hz | 250 Hz | 2.5 kHz | 25 kHz | 250 kHz |
| 60 Hz | 300 Hz | 3 kHz | 30 kHz | 300 kHz |
| 80 Hz | 400 Hz | 4 kHz | 40 kHz | |
| | 500 Hz | 5 kHz | 50 kHz | |
| | 600 Hz | 6 kHz | 60 kHz | |
| | 800 Hz | 8 kHz | 80 kHz | |

■ **↓(-)**

This softkey is the fine frequency decrement softkey used to decrease the test frequency to the next sequential lower frequency point. There are ten frequency points between successive tenfold values. The frequency points set by using this softkey are the same values as set by using **↑(+)**.

■ **↓(--)**

This softkey is the coarse frequency decrement softkey which is used to decrease the test frequency to the next sequentially lower tenfold value. The frequency points set by using this softkey are the same as the frequency points set by using **↑(++)**.

- 2) Select and set the test frequency by using either the softkeys or the numeric entry keys. When the test frequency is entered by using the numeric entry keys, the softkey labels are changed to the available units (Hz, kHz, and MHz). You can use these softkeys instead of **ENTER** to enter the units and enter the data. When **ENTER** is used, the numeric data is entered with Hz as the default unit.

3.2.5 Oscillator Level

TH2819A's oscillator level can be set as the effective value (RMS value) of a sine wave of the test frequency from the TH2819A's internal oscillator. You can set either the oscillator voltage level or the oscillator current level. The output impedance is 100 Ω or 30 Ω selectable. When DCR measurement is selected, "----" is displayed in the LEVEL field.

Note: the set value of the oscillator current level is the value set when the measurement contacts (UNKNOWN Terminals) are shorted together. The set value of the oscillator voltage level is the value set when the measurement contacts (UNKNOWN Terminals) are opened.

TH2819A can measure a device with a constant voltage or current level by using the automatic level control function. The automatic level control function (ALC field) can be set to ON on the MEAS SETUP page. When a constant voltage or current level measurement is performed, the asterisk mark (*) is located at the end of the oscillator level value. For more information about the automatic level control function, refer to MEAS SETUP page.

Front Panel Operation for Setting the Oscillator Level

There are two ways to set the oscillator level. One is to use the softkeys, and the other is to use the numeric entry keys.

Perform the following steps to set the oscillator level.

1) Move the cursor to the LEVEL field. The following softkeys will be displayed.



Press this softkey to increase the oscillator's output level.



Press this softkey to decrease the oscillator's output level.

2) Select and set the oscillator level by using either the softkeys or the numeric entry keys. When the oscillator level is entered by using the numeric entry keys, the softkey labels are changed to the available units labels (mV, V, μ A, mA, and A), and you can use these softkeys to enter the units and enter the data instead of **ENTER**. When **ENTER** is used, the numeric data is entered with V or A as the default unit.

Note: when you want to change the oscillator level from voltage to current or from current to voltage, the numeric entry keys and the unit softkeys must be used.

3.2.6 DC Bias

TH2819A has internal DC bias voltage with 0 V, 1.5 V and 2.0 V optional. When DCR measurement is selected for TH2819A, “----“ is displayed in the BIAS field.

Front Panel Operation for Setting the DC Bias:

There are two ways to set the DC bias, one is to use the softkeys, and the other is to use the numeric entry keys.

Perform the following steps to set the DC bias.

1) Move the cursor to the BIAS field. The following softkeys will be displayed.

■ 

Press this softkey to increase the DC bias level.

■ 

Press this softkey to decrease the DC bias level.

2) Set the DC bias to your desired bias by using either the softkeys or the numeric entry keys. When the DC bias is entered by using the numeric entry keys, the softkey labels are changed to the available units (mV, V, μ A, mA and A). You can use these softkeys instead of **ENTER**. When **ENTER** is used, the numeric data is entered with V or A as the default unit.

Note: when you want to change the DC bias from voltage to current or from current to voltage, you must use the numeric entry keys and the units' softkeys.

3) Set **DC BIAS** on the front panel to ON to output the DC bias. When DC Bias is set to ON, the DC Bias indicator will be displayed in the system information line.

3.2.7 Measurement Speed

TH2819A's measurement speed is determined by the following factors:

- Integration Time (A/D conversion)
- Averaging Rate (number of measurement averaged)

- Delay Time (time delay between the trigger and the start of the measurement)
- Measurement result's display time.

Generally, the slow measurement speed will result in more stable and more accurate result. SLOW, MED or FAST measurement speed can be selected.

Front Panel Operation for Setting the Measurement Speed

Perform the following steps to set the measurement speed.

- 1) Move the cursor to the SPEED field. The following softkeys will be displayed.
 - FAST
 - MED
 - SLOW
- 2) Use the preceding softkeys to select and set the measurement speed.

3.2.8 File Manage

TH2819A uses the internal EEPROM for storing and retrieving the maximum of 20 sets of instrument control settings. The following data will be stored in nonvolatile memory as one file.

- Control settings on the MEAS SETUP page.
 - Measurement Function
 - Test Frequency
 - Measurement Range
 - Oscillator Level
 - DC Bias
 - Measurement Speed
 - Averaging Rate
 - Delay Time
 - Trigger Mode
 - ALC on/off
 - V Monitor on/off
 - I Monitor on/off
 - Deviation Measurement A/B
 - Deviation Measurement A/B Reference Value
- Control settings on the LIMIT TABLE SETUP page.

- Measurement Parameter
- Nominal Value
- Limit Mode for the Primary Parameter
- Auxiliary Bin on/off
- Comparator Function on/off
- Low/High Limits for Each Bin

- Control setting on the BIN COUNT DISP page
 - Bin Count on/off

- Control settings on the LIST SWEEP SETUP page
 - Sweep Mode
 - List sweep parameters (frequency, level, bias)
 - All Sweep Points
 - All Low/High Limits including the limit mode (A or B)

- Display page format

- Control settings on the TRANS TEST SETUP page
 - Transformer Test Mode
 - Test Frequency and Level for TURN, Lx, Lk and DCR.

- Control settings on the TRANS LIMIT SETUP page
 - Deviation Mode
 - STD and High/Low Limits for Np, Ns, Lx, Lk and DCR

- Control settings on the FREQ RESP SETUP page
 - Measurement Function
 - Start Frequency
 - Stop Frequency
 - A/B Max and Min Scale
 - Points (120/240/480/960)

Front Panel Operation for File Manage

Perform the following steps to store the control settings to the internal nonvolatile memory.

- 1) Select and set all control settings on the MEAS DISPLAY page.
- 2) Move the cursor to the FILE field, the following softkey will be displayed.
 - FILE Manage
- 3) Press FILE Manage, The following softkeys will be displayed with the file list.
 - LOAD
 - STORE
 - DEL
 - COPY
 - ESC
- 4) Select a file No. from 1 to 20 by using the cursor keys.
- 5) Press STORE. The following softkeys will be displayed.
 - YES
 - NO
- 6) Press NO to return to Step 3.
- 7) Press YES, the message "FILE name:" will be displayed on the system message line.
- 8) Enter a record number by using the numeric entry keys and **ENTER** to store the current control settings.

Perform the following steps to load the control settings from the internal nonvolatile memory.

- 1) Move the cursor to the FILE field, the following softkey will be displayed.
 - FILE Manage
- 2) Press FILE Manage, The following softkeys will be displayed with the file list.
 - LOAD
 - STORE
 - DEL
 - COPY

 - ESC
- 3) Select a stored file from No.1 to 20, and Press LOAD. The following softkeys will be displayed.
 - YES
 - NO
- 4) Press NO to return to Step 2.
- 5) Press YES to load the file.

3.2.9 Useful Tools

TH2819A displays the measurement data with a six digit floating point display format. The fixed decimal point function is used to display the measurement data with a fixed point display format. This function can also be used to change the number of digits displayed. The display character of measurement result can be changed between big font and small font.

Front Panel Operation for Useful Tools

Perform the following steps to set fixed decimal point and set the display font for measurement result.

- 1) Move the cursor to the TOOLS field. The following softkeys will be displayed.
 - D.P. FIX A
 - D.P. FIX B
 - TINY FRONT
- 2) Press **D.P. FIX A** to fix the decimal point for the main parameter's data. The ▲ mark will be displayed at the decimal fixed point. Each time **D.P. FIX A** is pressed, the last digit is dropped, the value is rounded off.
- 3) Press **D.P. FIX B** to fix the decimal point for the sub parameter's data. The ▲ mark will be displayed at the decimal fixed point. Each time **D.P. FIX B** is pressed, the value is rounded off by giving one less digit.
- 4) Press **TINY FRONT** to change the measurement display digits from big front to tiny font. The softkey **TINY FRONT** will change to **BIG FONT**.
- 5) Press **BIG FONT** to change the measurement display digits from tiny font to big font. The softkey **BIG FONT** will change to **SMALL FONT**.

Note: in the following cases, the fixed decimal point function is automatically disabled.

- The measurement function is changed.
 - When the deviation measurement which is set on the MEAS SETUP page is performed, the deviation measurement function (Δ ABS, Δ %, OFF) is changed.
-

3.3 BIN No. DISP page

When you press **LCRZ**, and **BIN No.**, the BIN No. DISP page will be displayed. The bin sorting results are displayed in large characters and the measurement results are displayed in normal characters on the BIN No. DISP page, and the following measurement controls can be set from the BIN No. DISP page.

- Comparator Function ON/OFF (COMP)
- File Manage (FILE)
- Useful Tools (TOOLS)

There are four fields on this page: <BIN No. DISP>, COMP, FILE and TOOLS fields. Each control is described in the following paragraphs. This page also provides the following information in the monitor areas (each monitor area looks like a field, but is not). These conditions can be set from the MEAS SETUP page, and most conditions can be set from the MEAS DISP page.

- Measurement Function (FUNC)
- Measurement Range (RANGE)
- Test Frequency (FREQ)
- Oscillator Level (LEVEL)
- DC Bias (BIAS)
- Measurement Speed (SPEED)
- OPEN, SHORT, LOAD on/off setting conditions (CORR)

The available fields and the softkeys which correspond to each field on this page are shown in Figure 3-4 and Figure 3-5.

parameter limits. At the same time, a device whose primary parameter is within limits, but whose secondary parameter measurement result is not within limits can be sorted into an AUXiliary BIN. The comparator function is especially useful when the handler interface is installed on the TH2819A (handler interface is optional). These limit settings for bin sorting are only set on the LIMIT TABLE SETUP page. So this COMP field allows you to set the comparator function to ON or OFF only.

Front Panel Operation for Setting the Comparator Function to ON or OFF

Perform the following steps to set the comparator function to ON or OFF.

- 1) Move the cursor to the COMP field. The following softkeys will be displayed.
 - ON
 - OFF
- 2) Use the softkeys to set the comparator function to ON or OFF.

3.3.2 File Manage

Refer to 3.2.8 File Manage.

3.3.3 Useful Tools

The Bin No. DISP page provides no tools operation.

3.4 BIN COUNT DISP page

When you press **LCRZ** and **BIN COUNT**, the BIN COUNT DISP page will be displayed. On the BIN COUNT DISP page, the comparator's count results are displayed, and the following measurement controls can be set.

- File Manage (FILE)
- Useful Tools (TOOLS)

So there are three fields on this page: <BIN COUNT DISP>, FILE and TOOLS fields. This page also provides the following information in monitor areas (the monitor areas look like fields, but they are not). These conditions can be set from the LIMIT TABLE SETUP page.

- Nominal Value
- Measurement Function
- Bin Sorting Low/High Limits

The available fields and the softkeys which are corresponded to each field on this page are shown

in Figure 3-6 and Figure 3-7.

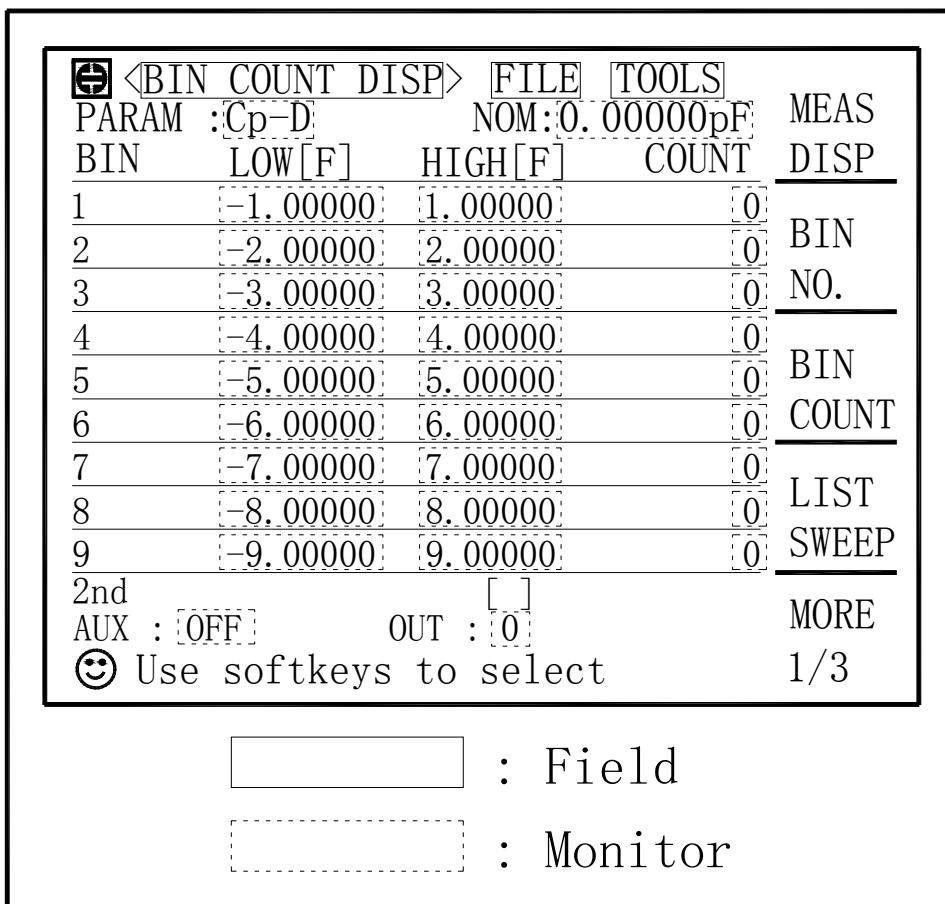

Figure 3-6 Available Fields on the BIN COUNT DISPLAY Page

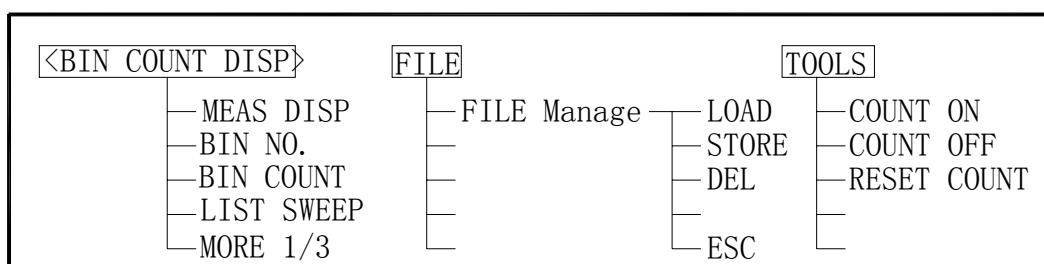

Figure 3-7 Available Softkeys on the BIN COUNT DISPLAY Page

3.4.1 File Manage

Refer to 3.2.8 File Manage.

3.4.2 Useful Tools

TH2819A has bin counting capability. When many devices are being sorted into bins by using the comparator function, the number of devices sorted into each bin is counted. The maximum count is 999999, the overflow message "----" will be displayed when this value is exceeded. The bin counter will still be operating, so you can only get the count data via GPIB.

Perform the following steps to set the counter function to ON or OFF from the BIN COUNT DISP page.

- 1) Move the cursor to TOOLS field on the BIN COUNT DISP page. The following softkeys will be displayed.
 - COUNT ON
 - COUNT OFF
 - RESET COUNT
- 2) Press **COUNT ON** to set the counter function to ON. An arrow ► will be displayed at the left of COUNT.
- 3) Press **COUNT OFF** when you want to set the counter function to OFF. The arrow ► will disappear.
- 4) Press **RESET COUNT** when all counts are reset to zero. The message "Resetting count. Sure? " will be displayed on the system message line, and **YES** and **NO** softkeys will be displayed. Press **YES**.

3.5 LIST SWEEP DISP Page

TH2819A's LIST SWEEP function permits entry of up to ten frequencies, signal levels, or DC bias levels, and the measurement limits on the LIST SWEEP SETUP page. These points are automatically swept and the measurement results are compared with the limits set. When you press **LCRZ** and **LIST SWEEP**, the LIST SWEEP DISP page will be displayed. On the LIST SWEEP DISP page, the sweep points are swept and the measurement results are compared with the limits. During a sweep, an arrow ► will appear on the left side of the current measuring list sweep point. The following measurement controls can be set from this page. (Each field in parenthesis is used when that control is set.)

- Sweep Mode of the List sweep Measurement (MODE)
- File Manage (FILE)
- Useful Tools (TOOLS)

So there are four fields on this page: <LIST SWEEP DISP>, MODE, FILE and TOOLS fields. The list sweep point can not be set on this page, but can only be set on the LIST SWEEP SETUP page.

The available fields and the softkeys which are corresponding to each field on this page are shown

in Figure 3-8 and Figure 3-9.

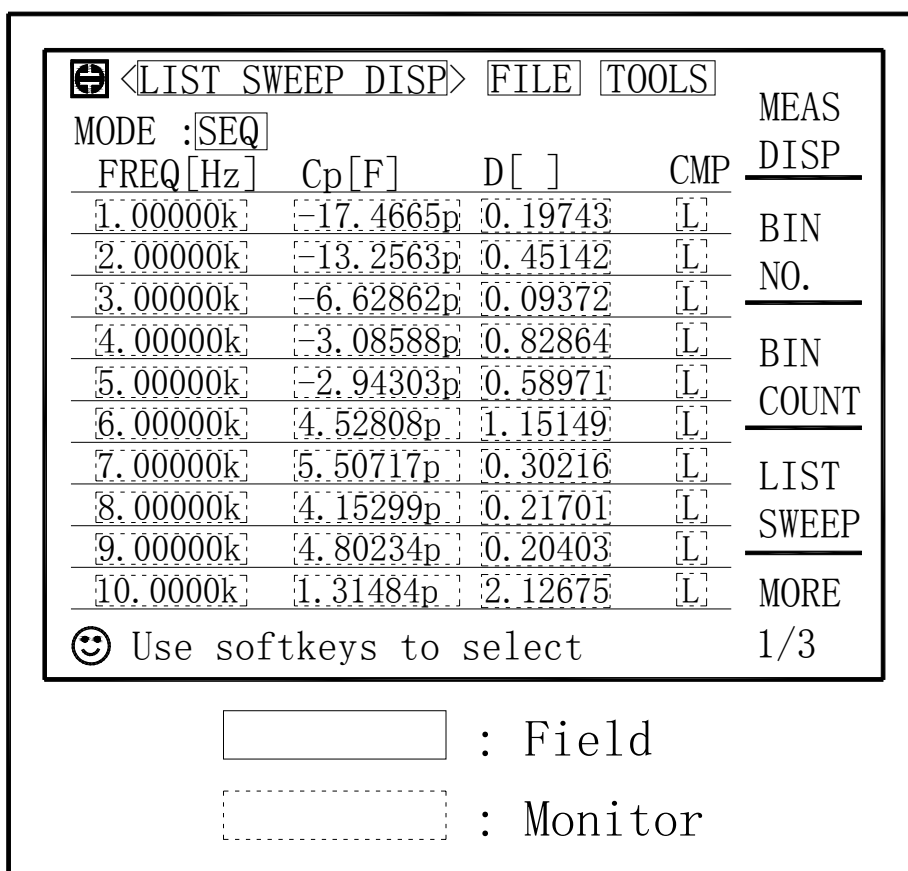

Figure 3-8 Available Fields on the LIST SWEEP DISP Page

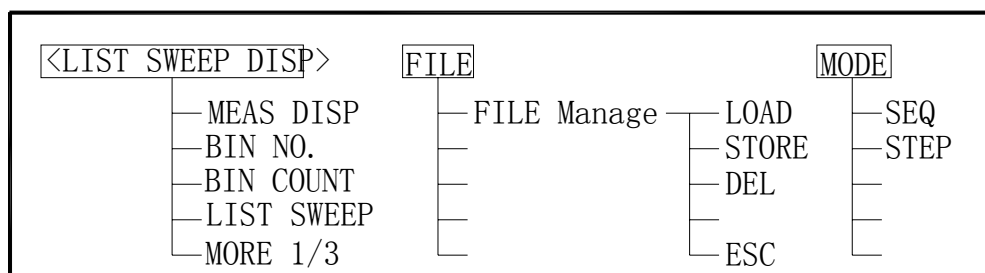

Figure 3-9 Available Softkeys on the LIST SWEEP DISP Page Sweep Mode

TH2819A List Sweep Measurement function permits up to 10 test frequencies, oscillator levels, or DC bias points to be automatically measured. There are two measurement modes for list sweep measurements: sequential (SEQ) mode and step (STEP) mode. In the case of SEQ mode, when TH2819A is triggered once, all sweep points are automatically swept. In the case of the STEP mode,

when the TH2819A is triggered, the sweep point is swept by one step.

Front Panel Operation for Setting the Sweep Mode of the List Sweep Measurement

Perform the following steps to set the list sweep measurement mode to the SEQ or STEP modes.

- 1) Move the cursor to the MODE field. The following softkeys will be displayed.
 - SEQ
 - STEP
- 2) Use the softkeys to select and set the list sweep measurement mode (SEQ or STEP mode).

3.5.1 File Manage

Refer to 3.2.8 File Manage.

3.5.2 Useful Tools

There are no tools on LIST SWEEP DISP page.

3.6 MEAS SETUP Page

When you press **LCRZ** and **MORE 1/3**, the MEAS SETUP page will be displayed. On this MEAS SETUP page, all of the following measurement control functions can be set. (Each field in parenthesis is used when each control is set.)



- Measurement Function (FUNC)
- Measurement Range (RANGE)
- Test Frequency (FREQ)
- Oscillator Level (LEVEL)
- DC Bias (BIAS)
- Measurement Speed (SPEED)
- Trigger Mode (TRIG)
- Automatic Level Control (ALC)
- Bias Current Isolation Mode ON/OFF (ISO)
- Averaging Rate (AVG)
- Voltage Level Monitor ON/OFF (Vm)
- Current Level Monitor ON/OFF (Im)
- Delay Time (DELAY)
- Internal Resistance (INT R)

- File Manage (FILE)
- Useful Tools (TOOLS)
- Deviation Measurement A Mode (DEV A)
- Deviation Measurement B Mode ((DEV B)
- Reference Value for the Deviation Measurement A (REF A)
- Reference Value for the Deviation Measurement B ((REF) B)

Some fields on the MEAS SETUP page are the same to the fields on the MEAS DISP page as follows. So these fields are not described in this Chapter, and the other functions on the MEAS SETUP page are described in the following paragraphs.

- Measurement Function (FUNC)
- Measurement Range (RANGE)
- Test Frequency (FREQ)
- Oscillator Level (LEVEL)
- DC Bias (BIAS)
- Measurement Speed (SPEED)

The available fields and the softkeys which are corresponding to each field on this page are shown in Figure 3 -10 and Figure 3-11.

| | | | | |
|---|------------------------|-------|-------------|----------------|
|  | <MEAS SETUP> | FILE | TOOLS | MEAS SETUP |
| FUNC | : Cp-D | RANGE | : AUTO | <u>SETUP</u> |
| FREQ | : 100.000Hz | BIAS | : 0.000V | CORREC TION |
| LEVEL | : 1.000V | SPEED | : SLOW | <u>TION</u> |
| TRIG | : INT | AVG | : 1 | LIMIT TABLE |
| ALC | : OFF | Vm | : OFF | <u>TABLE</u> |
| DELAY | : 0ms | Im | : OFF | LIST SETUP |
| INT R | : 100 Ω | ISO | : OFF | <u>SETUP</u> |
| DEV A | : OFF | REF A | : 0.00000pF | MORE |
| B | : OFF | B | : 0.00000p | 2/3 |
|  | Use softkeys to select | | | |

: Field
 : Monitor

Figure 3-10 Available Fields on the MEAS SETUP Page

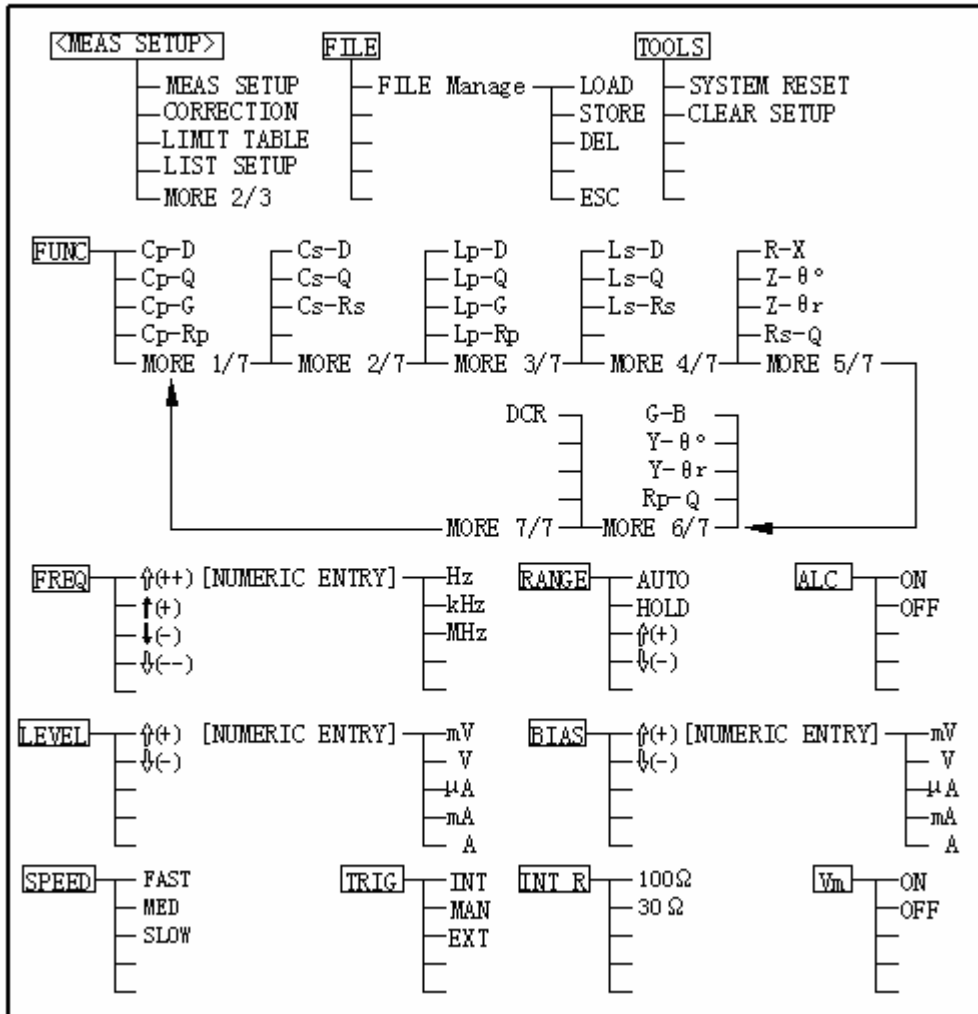

Figure 3-11 Available Softkeys on the MEAS SETUP Page (1/2)

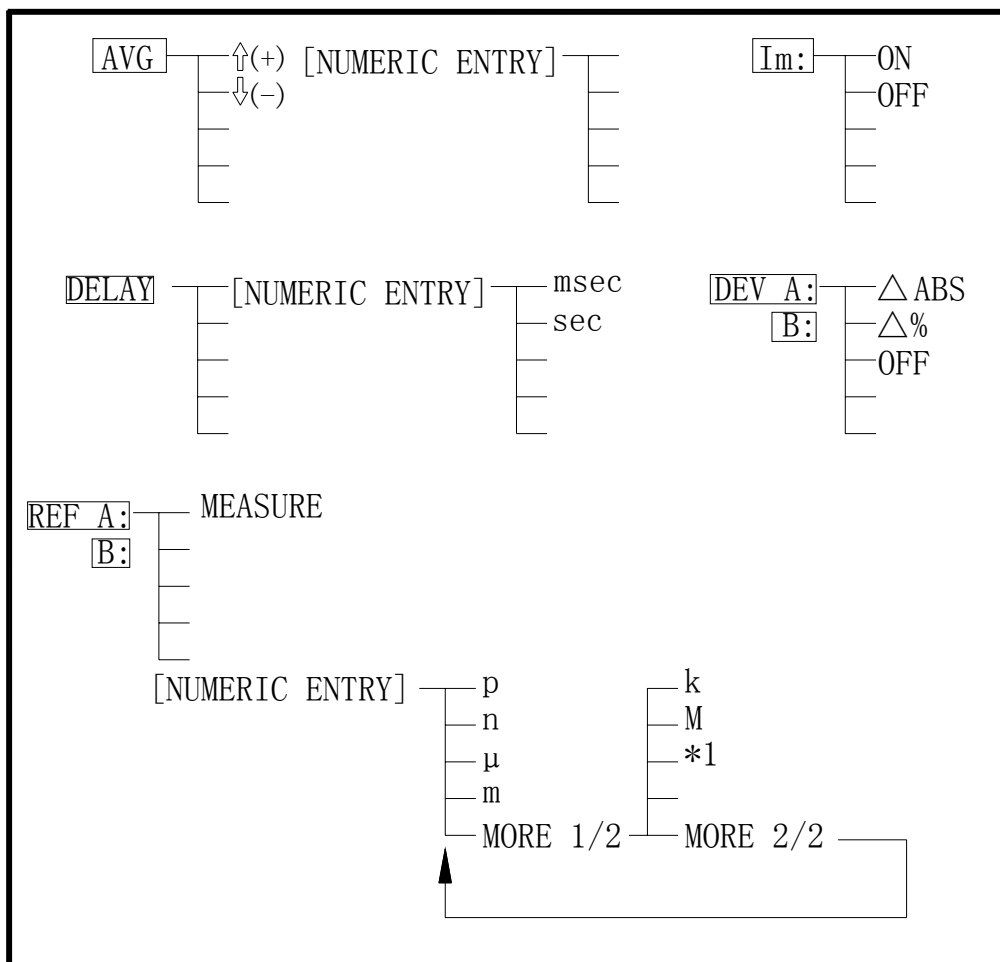

Figure 3-11 Available Softkeys on the MEAS SETUP Page (2/2)

3.6.1 Trigger Mode

TH2819A has four trigger modes: INTernal, EXTernal, MANual and BUS.

When the trigger mode is set to INT trigger mode, TH2819A repeats the measurements continuously.

When the trigger mode is set to MAN trigger mode. TH2819A performs a single measurement when **TRIGGER** on the front panel is pressed.

When the trigger mode is set to EXT trigger mode, TH2819A performs a single measurement when a positive TTL pulse is applied to the Handler Interface connector on the rear panel.

When the trigger mode is set to BUS trigger mode, TH2819A performs a single measurement when

the TRIGGER command is sent to TH2819A via GPIB. Then the BUS trigger mode cannot be set on the front panel.

Note: TH2819A ignores a trigger while a measurement is in progress. So please trigger TH2819A after the measurement is completed.

Select the EXT trigger mode when TH2819A is triggered via an optional interface.

Front Panel Operation for Setting the Trigger Mode

Perform the following steps to set the trigger mode except for in the BUS TRIG mode. To set the trigger mode in the BUS TRIG mode, the TRIGGER:SOURce BUS command should be sent via GPIB.

1) Move the cursor to the TRIG field. The following softkeys will be displayed.

- INT
- MAN
- EXT

2) Set the trigger mode by using the softkeys.

3.6.2 Automatic Level Control Function

The automatic level control (ALC) function regulates the actual test level (voltage across the DUT, or current through the DUT) to your desired level. So to use this function, the test signal voltage or current level at the DUT can be held constant.

When the automatic level control function is used, the oscillator level can be set as follows.

Voltage Level: 10 mV_{rms} to 1V_{rms}

Current Level: 100 μA_{rms} to 10 mA_{rms}

Note: When the ALC function is active, if the oscillator level setting exceeds the above limits, the ALC function is automatically set to OFF and the setting value is entered as a no normal oscillator level.

Front Panel Operation for Setting the Automatic Level Control Function

Perform the following steps to set the automatic level control function to ON or OFF.

1) Move the cursor to the ALC field. The following softkeys will be displayed.

- ON

- OFF

- 2) Press **ON** to set the automatic level control function to ON. Press **OFF** to set the automatic level control function OFF.

3.6.3 Bias Current Isolation Function

This bias current isolation function prevents the DC current from affecting the measurement input circuit. The ISO field allows you to set the bias current isolation function to ON or OFF. When the bias current isolation function is set to ON, the bias current through the device can be up to 100 mA. When the bias current isolation function is set to OFF, the current through the device can be set to the values listed in Table 3-2. When the current through a device exceeds the values listed in Table 3-2, normal measurement can't be performed.

Table 3-2 Maximum DC Bias Current

| | | | | | | | | | |
|-------------------|------|------|-------|-------|------|-------|-------|-------|--------|
| Measurement Range | 10Ω | 30Ω | 100 Ω | 300 Ω | 1 kΩ | 3 kΩ | 10 kΩ | 30 kΩ | 100 kΩ |
| Max. current | 2 mA | 2 mA | 2 mA | 2 mA | 1 mA | 300μA | 100μA | 30μA | 10μA |

Note: The bias current isolation function influences the measurement accuracy. So when measuring a high impedance device at low frequency with low bias current, the bias current isolation function should be set to OFF.

Front Panel Operation for Setting the Bias Current Isolation Function

Perform the following steps to set the bias current isolation function to ON or OFF when the bias current board has been installed.

- 1) Move the cursor to the ISO field. The following softkeys will be displayed.
 - ON
 - OFF
- 2) Press **ON** to set the bias current isolation function to ON. Press **OFF** to set the bias current isolation function to OFF.

3.6.4 Averaging Rate

TH2819A's averaging rate function computes the average of two or more A/D conversion results. The number of the average can be set from 1 to 255 in steps of 1.

Front Panel Operation for Setting the Averaging Rate

Perform the following steps to set the averaging rate.

- 1) Move the cursor to the AVG field. The following softkeys will be displayed.
 - **↑(+)**
This softkey is used to increase the averaging rate.
 - **↓(-)**
This softkey is used to decrease the averaging rate.
- 2) Use the softkeys to set the average rate, or enter the average rate by using the numeric entry keys, and **ENTER**.

3.6.5 Level Monitor Function

The level monitor function allows you to monitor the actual voltage level across the device under test or the actual current level through the device under test. The voltage monitor value is only displayed on the MEAS DISP page at Vm monitor area. The current monitor value is only displayed on the MEAS DISPLAY page at Im monitor area.

Note: The correction function affects the level monitor function. So the monitor value may be changed when the correction data is changed or the OPEN/SHORT/LOAD correction ON/OFF condition is changed.

Front Panel Operation for Setting the Level Monitor Function

Perform the following steps to set the level monitor function to ON or OFF.

- 1) Move the cursor to the Vm field. The following softkeys will be displayed.
 - **ON**
 - **OFF**
- 2) Press **ON** to set the voltage level monitor function to ON. Press **OFF** to set the voltage level monitor function to off.

- 3) Move the cursor to the Im field. The following softkeys will be displayed.
 - ON
 - OFF
- 4) Press **ON** to set the current level monitor function to ON. Press **OFF** to set the current level monitor function to OFF.

3.6.6 Delay Time

TH2819A's delay time function allows you to set a trigger delay, so TH2819A will delay of the measurement after it is triggered. (When the list sweep measurement is performed, TH2819A will delay the measurement at each sweep point.) The trigger delay time can be set from 0 s to 60 s in 1 ms step. This function is useful when a component handler triggers the TH2819A before the stable contact is made with DUT.

Front Panel Operation for Setting the Delay Time

Perform the following steps to set the delay time.

- 1) Move the cursor to the DELAY field.
- 2) Enter the delay time by using the numeric entry keys. When one of the numeric entry keys is pressed, the following unit softkeys will be displayed, these can be used instead of **ENTER**.
 - msec
 - sec

3.6.7 Internal Resistance

TH2819A has two kinds of internal resistances (or output impedances) for choice 100 Ω or 30 Ω . It is useful to make it compatible with other instrument when an inductance is measured.

Front Panel Operation for Setting the Internal Resistance

Perform the following steps to set the delay time.

- 1) Move the cursor to the INT R field. The following softkeys will be displayed.
 - 100 Ω
 - 30 Ω
- 2) Press **100 Ω** to select the 100 Ω output impedance and press **30 Ω** to select the 30 Ω output impedance.

3.6.8 Deviation Measurement Functions

The deviation measurement function allows you to display the deviation value instead of the actual measurement value. The deviation value is the value calculated by taking the difference between the actual measurement value and a previous stored reference value. This function is useful when the change of a component's value versus changes in temperature, frequency, bias, etc. are being observed. Deviation measurements can be made for either or both primary parameter or secondary parameter measurements. There are two types of deviation measurements.

- Δ ABS (Delta ABSolute) deviation measurement

The difference between the measured value of the DUT and a previous stored reference value are displayed. The formula used to calculate the deviation is as follows.

$$\Delta\text{ABS} = X - Y$$

X: The measured value of the DUT

Y: The stored reference value

- $\Delta\%$ (Delta percent) deviation measurement

The difference between the measured value of the DUT and a previous stored reference value are displayed as a percentage of the reference value. The formula used to calculate the percent deviation is as follows.

$$\Delta\% = (X - Y) / Y \times 100 [\%]$$

X: The measured value of the DUT

Y: The stored reference value

Front Panel Operation for the Deviation Measurement Function

Perform the following steps to execute the deviation measurement function.

- 1) Move the cursor to the REF A field to enter the reference value for the primary parameter. The following softkey will be displayed.

- MEA-SURE

When the reference device is connected to the test terminal, press MEA-SURE, TH2819A measures the device, and the measurement results are entered as a reference value for REF A and REF B automatically.

- 2) Enter the reference value for the primary parameter by using MEA-SURE or the numeric entry keys.
- 3) Move the cursor to the (REF) B field to enter the reference value for the secondary parameter. The following softkey will be displayed.

- MEA-SURE

When the reference device is connected to the test terminal, press **MEA-SURE**, TH2819A measures the device, and the measurement results are entered as a reference value for REF A and REF B values.

- 4) Enter the reference value for the secondary parameter using **MEA-SURE** or the numeric entry keys. If the reference values for A and B are entered by using **MEA-SURE** in step 2, please skip this step.
5. Move the cursor to the DEV A field. The following softkeys will be displayed.
 - **ΔABS**
 - **Δ%**
 - **OFF**
- 6) Select and press a softkey to select the deviation mode for the primary parameter.
- 7) Move the cursor to the (DEV) B field. The following softkeys will be displayed.
 - **ΔABS**
 - **Δ%**
 - **OFF**
- 8) Select and press a softkey to select the deviation mode for the secondary parameter.

3.6.9 File Manage

Refer to 3.2.8 File Manage

3.6.10 Useful Tools

The SYSTEM RESET function allows you to reset TH2819A, the CLEAR SETUP function allows you to reset all the operation on MEAS SETUP page to the default settings.

Front Panel Operation for the SYSTEM RESET and CLEAR SETUP Function

Perform the following steps to reset the system or load the default settings on the MEAS SETUP PAGE.

- 1) Move the cursor to the TOOLS field. The following softkeys will be displayed.
 - **SYSTEM RESET**
 - **CLEAR SETUP**
- 2) Press **SYSTEM RESET** to reset TH2819A and press **CLEAR SETUP** to set all of the control settings on the MEAS SETUP page to the power-on default settings.

3.7 CORRECTION Page

When you press **LCRZ**, **MORE 1/3** and **CORRECTION**, the CORRECTION page will be displayed.

On the CORRECTION page, the OPEN, SHORT, LOAD correction for correcting the stray capacitance,

the residual impedance and the other errors can be performed. The correction function has two kinds of correction methods. In one method the open and short correction can be performed at all of the frequency points by using the interpolation method; in the other method, the open, short and load correction can be performed at the frequency points specified by yourself.

The following operations can be performed on this page. The field is in parenthesis.

- OPEN Correction (OPEN)
- SHORT Correction (SHORT)
- LOAD Correction (LOAD)
- Cable Length Selection (CABLE)
- Multi/Single Correction Mode Selection (MODE)
- Measurement Function for LOAD Correction (FUNC)
- Frequency 1, 2, 3 for OPEN, SHORT, LOAD Correction (FREQ1, FREQ2, and FREQ3)
- Reference Values (A, B) at each three frequencies for LOAD Correction (REF A, B)
- File Manage (FILE)
- Useful Tools (TOOLS)



There are eighteen available fields on this page: <CORRECTION>, FILE, TOOLS, OPEN, SHORT, LOAD, CABLE, MODE, FUNC, FREQ1, REF A, B, FREQ2, REF A, B, FREQ3, REF A, and B.

This page also provides the following monitor information (the monitor area looks like a field, but it is not).

- Actual Measurement Values for LOAD Correction
- Channel Number on the MULTI Correction Mode

The actual measurement values for LOAD Correction can be measured from the FREQ1, FREQ2, or FREQ3 fields on this page, and the channel number can be set by using the scanner interface connector or GPIB.

The available fields and the softkeys which are corresponding to each field on this page are shown in Figure 3-12 and Figure 3-13.

| | | | |
|--|--|-------|--------------|
|  <CORRECTION> | FILE | TOOLS | MEAS |
| OPEN : <input type="text" value="ON"/> | CABLE : <input type="text" value="0m"/> | | <u>SETUP</u> |
| SHORT : <input type="text" value="ON"/> | MODE : <input type="text" value="Single"/> | | CORREC |
| LOAD : <input type="text" value="OFF"/> | CH NO. : <input type="text" value=""/> | | <u>TION</u> |
| | FUCN : <input type="text" value="Y-θ r"/> | | LIMIT |
| FREQ 1 : <input type="text" value="10.0000kHz"/> | | | <u>TABLE</u> |
| REF A : <input type="text" value="100.000mS"/> | B : <input type="text" value="-0.00000r"/> | | LIST |
| MEA A : <input type="text" value="100.000mS"/> | B : <input type="text" value="0.00000r"/> | | <u>SETUP</u> |
| FREQ 2 : <input type="text" value="100.000kHz"/> | | | MORE |
| REF A : <input type="text" value="4.53026mS"/> | B : <input type="text" value="1.57032r"/> | | |
| MEA A : <input type="text" value="4.53758mS"/> | B : <input type="text" value="1.50670r"/> | | |
| FREQ 3 : <input type="text" value="300.000kHz"/> | | | |
| REF A : <input type="text" value="100.000mS"/> | B : <input type="text" value="0.00000r"/> | | |
| MEA A : <input type="text" value="100.000mS"/> | B : <input type="text" value="0.00000r"/> | | |
|  Use softkeys to select | | | 2/3 |

: Field
 : Monitor

Figure 3-12 Available Fields on the CORRECTION Page

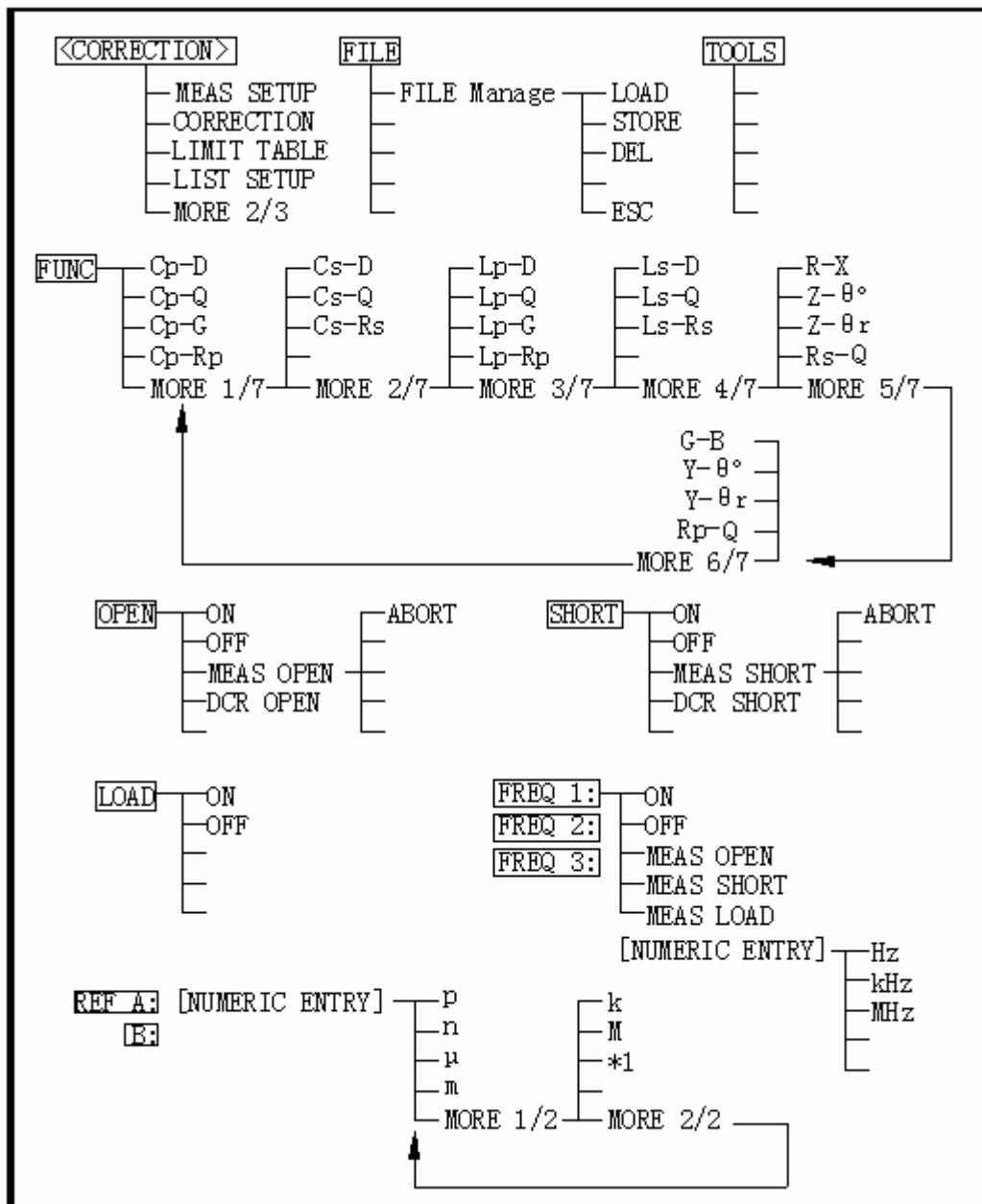

Figure 3-13 Available Softkeys on the CORRECTION Page

3.7.1 OPEN Correction

TH2819A's OPEN correction capability can eliminate the errors caused by the stray admittance (G, B) in parallel with the device under test (Refer to Figure 3-14).

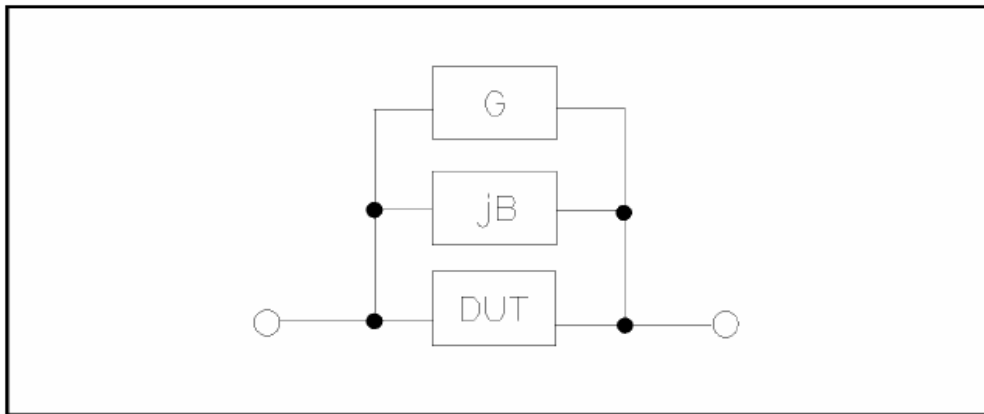

Figure 3-14 Stray Admittance

TH2819A uses two kinds of OPEN correction data as follows.

- The OPEN correction is performed at all 41 frequency points, independent of the test frequency you set. Except for those 41 frequency points, the OPEN correction data for each measurement point over the specified range is calculated with the method of the interpolation. The following is a list of the 41 preset frequency points. Move the cursor to OPEN field; press the softkey **MEAS OPEN** to perform the open correction for all the frequency.

| | | | | |
|-------|--------|---------|--------|---------|
| 20 Hz | 100 Hz | 1 kHz | 10 kHz | 100 kHz |
| 25 Hz | 120 Hz | 1.2 kHz | 12 kHz | 120 kHz |
| 30 Hz | 150 Hz | 1.5 kHz | 15 kHz | 150 kHz |
| 40 Hz | 200 Hz | 2 kHz | 20 kHz | 200 kHz |
| 50 Hz | 250 Hz | 2.5 kHz | 25 kHz | --- kHz |
| 60 Hz | 300 Hz | 3 kHz | 30 kHz | --- kHz |
| 80 Hz | 400 Hz | 4 kHz | 40 kHz | |
| | 500 Hz | 5 kHz | 50 kHz | |
| | 600 Hz | 6 kHz | 60 kHz | |
| | 800 Hz | 8 kHz | 80 kHz | |

- The OPEN correction data which is taken at the frequency points you specify allows you to set up three frequency points in the **FREQ1**, **FREQ2**, and **FREQ3** fields. To take the OPEN correction data at the frequency points you specify, move the cursor to **FREQ1**, **FREQ2** or **FREQ3**, and then press **MEAS OPEN** to perform open correction for **FREQ1**, **FREQ2** and **FREQ3** respectively.

Front Panel Operation for the Open Correction

There are two procedures: OPEN correction with the interpolation method, and OPEN correction at the frequency points you specify.

Perform the following steps to execute the OPEN correction at all frequency points with the method of the interpolation. When you want to perform the OPEN correction at a single frequency point, refer to "LOAD Correction".

- 1) Move the cursor to the OPEN field. The following softkeys will be displayed.
 - ON
 - OFF
 - MEAS OPEN
 - DCR OPEN
- 2) Connect your test fixture to the UNKNOWN Terminals without connecting the device under test.
- 3) Press **MEAS OPEN**. TH2819A will measure the OPEN admittance (capacitance, and inductance) at the preset frequency points. The time required to measure the open correction data is approximately 75 s. During the OPEN correction measurement, the following softkey is available.
 - **ABORT**This softkey is used to stop an OPEN correction data measurement. The previous OPEN correction data will still be stored.
- 4) Press **DCR OPEN**. TH2819A will measure the OPEN resistance under DCR function.
- 5) Press **ON** to enable DCR open correction, TH2819A will perform the OPEN correction on subsequent measurements. The current frequency correction data acquired by the interpolation will be used for open correction calculation when the **FREQ1**, **FREQ2**, and **FREQ3** fields are set to OFF. When the **FREQ1**, **FREQ2**, and **FREQ3** fields are set to ON, and the test frequency is equal to **FREQ1/2/3**, the OPEN correction data at **FREQ1/2/3** will be used for open correction.
- 6) Press **OFF** to not perform the OPEN correction calculations on subsequent measurements.

3.7.2 SHORT Correction

TH2819A's SHORT correction capability corrects for the residual impedance (R, X) in serial with the device under test (Refer to Figure 3-15).

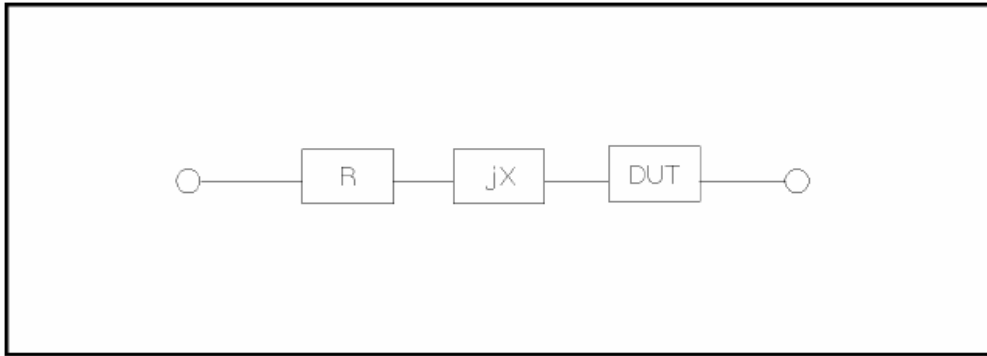

Figure 3-15 Residual Impedance

TH2819A uses the following two kinds of SHORT correction data.

- The SHORT correction is performed at all 41 frequency points, independent of the test frequency you set. Except for those 41 frequency points, the SHORT correction data for each measurement point over the specified range is calculated with the method of the interpolation. The following is a list of the 41 preset frequency points. Move the cursor to SHORT field, press the softkey **MEAS SHORT** to perform the SHORT correction for all the frequency.
- The SHORT correction data which is taken at the frequency points you specify. You can set up three frequency points in the **FREQ1**, **FREQ2** and **FREQ3** fields.
To take the short correction data at the frequency points you specify, move the cursor to **FREQ1**, **FREQ2** or **FREQ3**, and then press **MEAS SHORT** to perform short correction for **FREQ1**, **FREQ2** and **FREQ3** respectively.

Front Panel Operation for the Short Correction

There are two procedures: SHORT correction at all frequency points, and SHORT correction at user specified frequency points.

Perform the following steps to execute the SHORT correction for all frequency points. When you want to execute the short correction at the user specified frequency points, refer to "LOAD Correction".

- 1) Move the cursor to the SHORT field. The following softkeys will be displayed.
 - **ON**
 - **OFF**
 - **MEAS SHORT**
 - **DCR SHORT**
- 2) Connect the test fixture to the UNKNOWN Terminals, and short the measurement contacts together.
- 3) Press **MEAS SHORT**. TH2819A will measure the short impedance (inductance and resistance) at

the preset frequency points. The time required to measure the short correction data is approximately 75 s. During the SHORT correction measure cycle, the following softkey is available.

■ **ABORT**

This softkey is used to stop the short correction measurement. The previous SHORT correction data is still stored.

- 4) Press **DCR SHORT**. TH2819A will measure the SHORT resistance under DCR function.
- 5) Press **ON** to enable DCR short correction calculation and perform the SHORT correction calculations on subsequent measurements when the **FREQ1**, **FREQ2**, and **FREQ3** fields are set to **OFF**. When the **FREQ1**, **FREQ2**, and **FREQ3** fields are set to **ON**, and the test frequency is equal to **FREQ1/2/3**, the SHORT correction data at **FREQ1/2/3** is used.
- 6) Press **OFF** to halt SHORT correction calculations on subsequent measurements.

3.7.3 LOAD Correction

TH2819A's LOAD correction capability corrects the other errors by using the transmission coefficient derived from the relationship between a standard reference value to the actual measurement value at the frequency points you specify (**FREQ1**, **FREQ2** and **FREQ3**). So **OPEN/ SHORT/LOAD** corrections can be performed at the frequency points you specify. The three frequency points can be set in the **FREQ1**, **FREQ2**, and **FREQ3** fields. The standard reference values are set in the **REF A** and **B** fields. Before entering the standard reference values, the measurement function for the standard must be set in the **FUNC** field. The standard value can be measured by using **MEAS LOAD**, which is displayed when the cursor is moved to the **FREQ1**, **FREQ2**, or **FREQ3** fields.

Front Panel Operation for the OPEN/SHORT/LOAD Correction

Perform the following steps to perform the **OPEN/ SHORT/LOAD** correction at the frequency points you want to specify.

- 1) Move the cursor to the **FREQ1**, **FREQ2**, or **FREQ3** field to specify the frequency for the **OPEN/SHORT/LOAD** correction. The following softkeys will be displayed.

■ **ON**

This softkey is used to make the **OPEN/SHORT/LOAD** correction data at the **FREQ1**, **FREQ2**, or **FREQ3** frequency point valid.

■ **OFF**

This softkey is used to make the **OPEN/SHORT/LOAD** correction data at the **FREQ1**, **FREQ2**, or **FREQ3** frequency point invalid.

■ **MEAS OPEN**

This softkey is used to perform an OPEN correction measurement at the FREQ1, FREQ2, or FREQ3 frequency points.

■ **MEAS SHORT**

This softkey is used to perform a SHORT correction measurement at the FREQ1, FREQ2, or FREQ3 frequency points.

■ **MEAS LOAD**

This softkey is used to perform a LOAD correction measurement at the FREQ1, FREQ2, or FREQ3 frequency points.

- 2) Press **ON** to show the previous frequency for the OPEN/SHORT/LOAD correction.
- 3) Enter the frequency by using the numeric entry keys. When pressing one of the numeric entry keys, the softkey labels are changed to the available units (**Hz**, **kHz**, and **MHz**), so you can use these softkeys to enter the unit without hitting **ENTER**. (When **ENTER** is used, the numeric data is entered with Hz.)
- 4) Connect the test fixture to the UNKNOWN Terminals.
- 5) Make the connection contacts open.
- 6) Press **MEAS OPEN**. TH2819A performs an OPEN correction measurement at the frequency points you specified. After which, the OPEN correction measurement data are displayed on the system message line.
- 7) Move the cursor to the OPEN field.
- 8) Press **ON** to perform the OPEN correction calculations for subsequent measurements at the specified frequency points.
- 9) Move the cursor to the FREQ1, FREQ2, or FREQ3 field at which you specified the frequency.
- 10) Short the connection contacts together.
- 11) Press **MEAS SHORT**. TH2819A will perform a SHORT correction measurement, and display the SHORT correction data on the system message line.
- 12) Move the cursor to the SHORT field.
- 13) Press **ON** to perform the SHORT correction calculations for subsequent measurements at the specified frequency points.
- 14) Prepare the standard device for measurement.
- 15) Move the cursor to the FUNC field.
- 16) Set the measurement function for your standard.
- 17) Move the cursor to the REF A field where you specified frequency.
- 18) Enter the pre-measured value of your standard primary parameter by using the numeric entry keys and the unit softkeys.

- 19) Move the cursor to the B field on the right side of REF A field.
- 20) Enter the standard secondary parameter value by using the numeric entry keys and the unit softkeys.
- 21) Move the cursor to the FREQ1, FREQ2 or FREQ3 field at which you specified the frequency.
- 22) Connect the standard to the test fixture.
- 23) Press **MEAS LOAD**. TH2819A will perform a LOAD correction measurement, and display the LOAD correction data on the system message line.
- 24) Move the cursor to the LOAD field.
- 25) Press **ON** to enable the LOAD correction calculations for subsequent measurements at the specified frequency points.

3.7.4 Measurement Function for the LOAD Correction

When the LOAD correction is performed, the reference (pre-measured) value of the standard must be entered. The reference value should be the same to the setting value of the measurement functions.

The LOAD correction corrects the errors by using the transmission coefficient derived from the relationship between the standard reference value and the actual measurement value. The specified function is used only for calculating the transmission coefficient.

Front Panel Operation for Setting the Standard's Measurement
Refer to 3.2.2 Measurement Function

3.7.5 Cable Length Selection

Only 0m can be selected now.

3.7.6 Multi/Single Correction Mode Selection

Refer to Scanner Interface (optional) Manual.

3.7.7 File Manage

Refer to 3.2.8 File Manage.

3.7.8 Useful Tools



No tool is provided on CORRECTION PAGE

3.8 LIMIT TABLE SETUP Page

When you press **LCRZ**, **MORE 1/3** and **LIMIT TABLE**, the LIMIT TABLE SETUP page will be displayed. The LIMIT TABLE SETUP page allows you to set TH2819A's comparator. TH2819A's built-in comparator can sort devices into a maximum of ten bins (BIN 1 to BIN 9 and one OUT OF BINS) by using a maximum of nine pairs of primary limits and one pair of secondary parameter limits. At the same time, devices whose primary parameter is within limits, but whose secondary parameter is not within limits, can be sorted into an AUXiliary BIN. The comparator function is especially useful when handler interface option is installed on TH2819A. These limit settings for bin sorting are only set on this LIMIT TABLE SETUP page.

- Measurement Parameter (PARAM)
- Comparator Function's Limit Mode (MODE)
- Nominal Value for tolerance mode (NOM)
- Auxiliary bin ON/OFF (AUX)
- Comparator Function ON/OFF (COMP)
- Low Limit Value of each bin (LOW)
- High Limit Value of each bin (HIGH)

The available fields and the softkeys which are corresponding to the fields on this page are shown in Figure 3-16 and Figure 3-17.

| | | | | | |
|--|----------|---------|---------|-------|-------------|
|  <LIMIT TABLE SETUP> | | | FILE | TOOLS | |
| PARAM : | Cp-D | NOM: | 0.00000 | pF | MEAS |
| MODE : | ABS | AUX : | OFF | COMP: | OFF |
| BIN | LOW[F] | HIGH[F] | | | |
| 1 | -1.00000 | 1.00000 | | | |
| 2 | -2.00000 | 2.00000 | | | |
| 3 | -3.00000 | 3.00000 | | | |
| 4 | -4.00000 | 4.00000 | | | |
| 5 | -5.00000 | 5.00000 | | | |
| 6 | -6.00000 | 6.00000 | | | |
| 7 | -7.00000 | 7.00000 | | | |
| 8 | -8.00000 | 8.00000 | | | |
| 9 | -9.00000 | 9.00000 | | | |
| 2nd | 0.00000 | 0.10000 | [] | | |
|  Use softkeys to select | | | | | MORE 2/3 |

: Field

Figure 3-16 Available Fields on the LIMIT TABLE SETUP Page

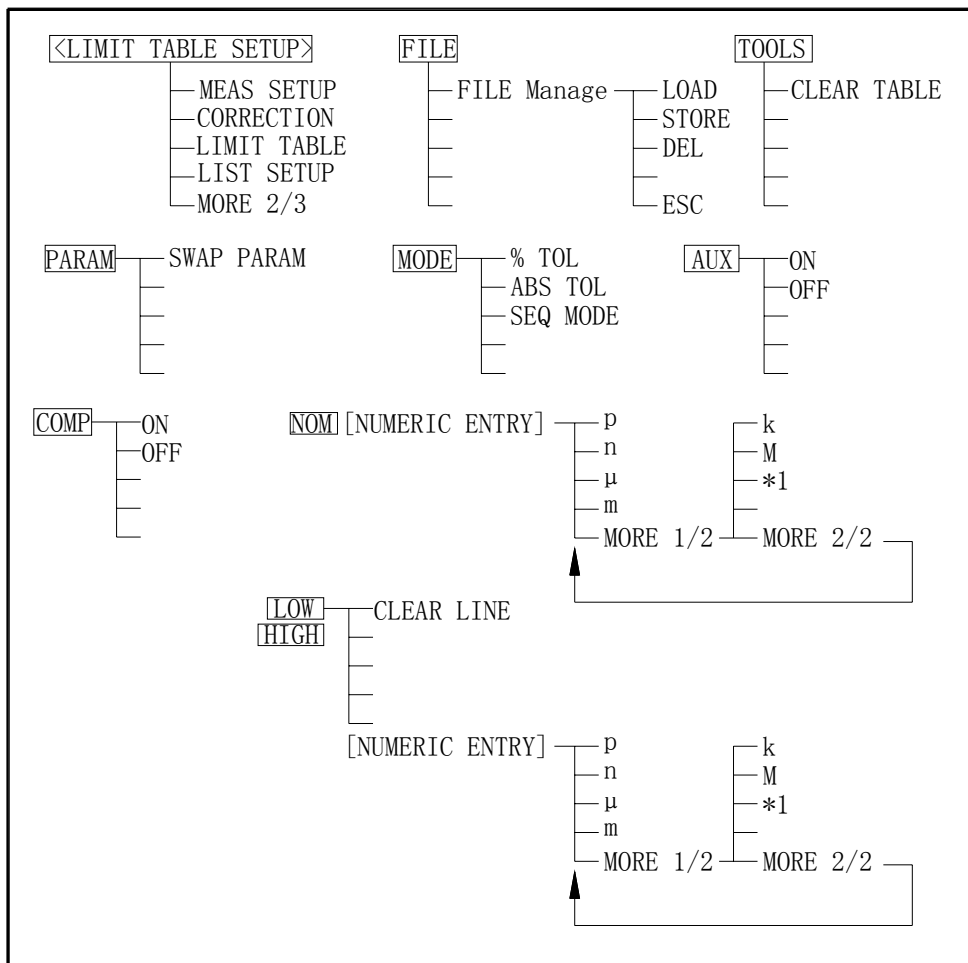

Figure 3-17 Available Softkeys on the LIMIT TABLE SETUP Page

3.8.1 Swap Parameter

The swap parameter function is used to swap the primary parameter for the secondary parameter in the PARAM field. For example, when the measurement function is Cp-D, the swap parameter function sets the measurement function to D-Cp. Then the comparison limits for D are a maximum of nine pairs of comparison limits, and the comparison limits for Cp are one pair now.

Front Panel Operation for Swapping the Primary Parameter for the Secondary Parameter

Perform the following steps to swap the primary parameter for the secondary parameter.

- 1) Move the cursor to the PARAM field. The following softkey will be displayed.
 - SWAP PARAM

- 2) Press **SWAP PARAM** to swap the primary parameter for the secondary parameter.
- 3) Press **SWAP PARAM** again to return the measurement function to the previous combination.

3.8.2 Limit Mode for Comparator

The two methods for specifying primary parameter limits are as follows: (Refer to Figure 3-18)

■ Tolerance Mode

The tolerance mode specifies comparison limits by the deviation from the specified nominal value. (The nominal value is specified at NOM field.) The deviation has two types: the deviation with the ratio in percent and the one with the absolute value.

■ Sequential Mode

The sequential mode specifies the measurement range as the comparison limit value. The limits must be set in order from the smallest value to the largest value.

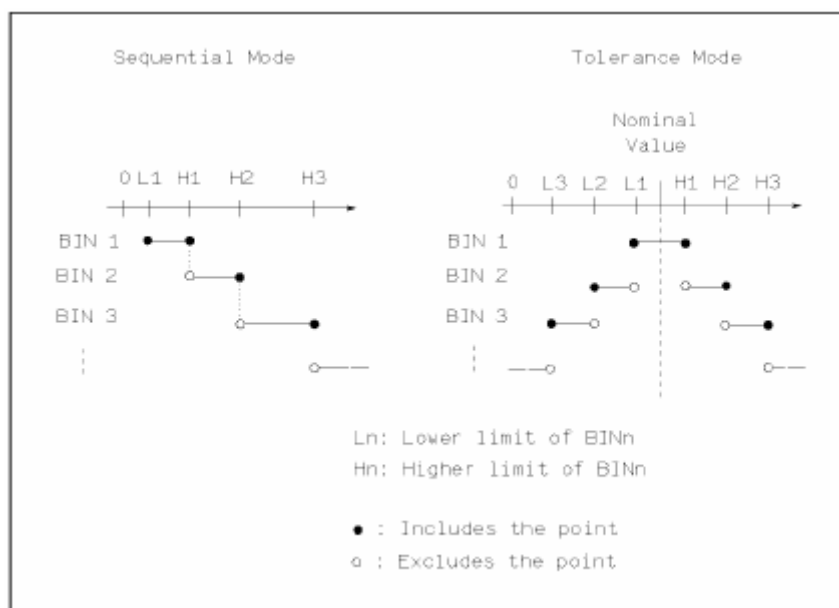

Figure 3-18 Tolerance Mode and Sequential Mode

Note: The limit values for tolerance mode sorting must be set in the order of the narrower limits to the wider limits. If BIN 1 has the widest limits, all of the DUTs will be sorted into BIN 1.

In tolerance mode sorting, the lower limit doesn't have to be less than the nominal value, and the upper limit doesn't have to be greater than the nominal value. They can be opening and they can be duplications.

Front Panel Operation for Setting the Limit Mode for the Comparator

Perform the following steps to set the limit mode for the comparator.

- 1) Move the cursor to the MODE field. Then the following softkeys will be displayed.

- **% TOL**

This softkey is used to set the limit mode to the tolerance mode (the ratio in percent).

- **ABS TOL**

This softkey is used to set the limit mode to the tolerance mode (parameter value).

- **SEQ**

This softkey is used to set the limit mode to the sequential mode.

- 2) Select and set the limit mode using the softkeys.

3.8.3 Nominal Value for Tolerance Mode

When the tolerance mode is used as a limit mode for the primary parameter, the nominal value must be set. The nominal value can be set within the display range.

When the limit mode for the primary parameter is the sequential mode, the nominal value can be set, but it has no meaning in the sequential mode.

Front Panel Operation for Setting the Nominal Value

Perform the following steps to set the nominal value.

- 1) Move the cursor to the NOM field.
- 2) Enter the nominal value by using the numeric entry keys. When the numeric data is entered, the suffix softkeys (**p**, **n**, **μ**, **m**, **k**, **M**, ***1**) can be used instead of **ENTER**. When **ENTER** is pressed, the numeric data is entered with the same unit selected last time. When ***1** is pressed, the numeric data is entered with the F, H and Ω as the default unit.

3.8.4 Comparator Function ON/OFF

TH2819A's built-in comparator can sort devices into a maximum of ten bins (BIN 1 to BIN 9 and the OUT OF BINS bin) by using a maximum of nine pairs of primary limits and one pair of secondary parameter limits. At the same time, a device whose primary parameter is within limits, but whose secondary parameter is not within limits, can be sorted into the AUXiliary BIN. The comparator function is especially useful when handler interface option is installed on the TH2819A.

Front Panel Operation for Setting the Comparator Function to ON or OFF

Perform the following steps to set the comparator function to ON or OFF.

- 1) Move the cursor to the COMP field. The following softkeys will be displayed.
 - ON
 - OFF
- 2) Use the softkeys to set the comparator function to ON or OFF.

3.8.5 Auxiliary Bin ON/OFF

When the secondary parameters affect the sorting results, the limits for the secondary parameter can be set in 2nd LOW/HIGH fields.

There are three patterns for the sorting area of the secondary parameter.

- When the secondary parameter limits are not specified on the LIMIT TABLE SETUP page.

Devices will be sorted according to primary parameter comparison results.

- When the secondary parameter limits are set and AUX BIN are set to OFF.

Only devices within secondary limits are sorted by the primary parameter. Devices not within the secondary parameter limits are sorted into OUT OF BINS even if the device's primary parameter is within limits.

- When the secondary parameter limits are set and AUX BIN are set to ON.

Devices whose primary parameter is not within limits are sorted into OUT OF BINS. Devices whose primary parameter is within limits, but whose secondary parameter is out of limits are sorted into the AUX BIN.

Note: When the lower limit of the secondary parameter is set only and the AUX BIN is set to ON, the devices whose primary parameter is within limits, but whose secondary parameter is equal to or below the lower limit are sorted into the AUX BIN; When the higher limit of the secondary parameter is set only and the AUX BIN is set to ON, the devices whose primary parameter is within limits, but whose secondary parameter is equal or above the higher limit are sorted into the AUX BIN.

Front Panel Operation for Setting the AUX BIN to ON or OFF

Perform the following steps to set the AUX BIN to ON or OFF.

- 1) Move the cursor to the AUX field. The following softkeys will be displayed.
 - ON
 - OFF
- 2) Select and press a softkey to set AUX BIN to ON or OFF.

3.8.6 Low/High Limits

TH2819A's built-in comparator can sort devices into a maximum of ten bins (BIN 1 to BIN 9, and OUT OF BINS) by using a maximum of nine pairs of primary parameter limits and one pair of secondary parameter limits. These primary parameter low/high limits can be set in the BIN 1 to BIN 9 LOW/HIGH fields, and the secondary parameter low/high limits can be set in the 2nd LOW/HIGH fields.

Front Panel Operation for Setting the Low/High Limits

Perform the following steps to set the bin sorting limits.

- 1) Set the measurement function and the nominal for the comparator function, the limit mode for the primary parameter.
- 2) Move the cursor to the TOOLS field, and perform the **clear table** function.
- 3) Move the cursor to the **BIN 1 LOW** field. When you use the tolerance mode, perform steps 4 through 7. When you use the sequential mode, perform steps 8 through 12.
- 4) Enter the limit value of the BIN 1 at BIN 1 LOW field by using the numeric entry keys. When one of the numeric entry keys is pressed, the suffix softkeys (**p**, **n**, **μ**, **m**, **k**, **M *1**) can be used instead of **ENTER**. When **ENTER** is pressed, the numeric data is entered with the same unit selected last time. When ***1** is pressed, the numeric data is entered with the F, H and Ω as the default unit. When the limit value of BIN 1 is entered in the BIN 1 LOW field, the BIN 1 low limit becomes $-$ (absolute value limit), and the BIN 1 high limit becomes $+$ (absolute value limit).
- 5) The cursor will be automatically moved to the BIN 2 LOW field. Repeat step 4 until the limits of the BIN 9 is entered. After that, the cursor will be moved to the 2nd LOW field.
- 6) Enter the low limit value of the secondary parameter. After that, the cursor will be automatically moved to the 2nd HIGH field.
- 7) Enter the high limit value of the secondary parameter.
- 8) Enter the low limit of the BIN 1 using the numeric entry keys. When the one of the numeric entry keys is pressed, the suffix softkeys (**p**, **n**, **μ**, **m**, **k**, **M *1**) can be used instead of **ENTER**. When **ENTER** is pressed, the numeric data is entered with the same unit selected last time. When ***1** is pressed, the numeric data is entered with the F, H and Ω as the default unit.
- 9) The cursor will be automatically moved to the BIN 1 HIGH field after entering the low limit of the BIN

1. Enter the high limit of the BIN 1.
- 10) The cursor will be automatically moved to the BIN 2 HIGH field. Because the BIN 2 low limit value is the same to the BIN 1 high limit value. Enter the high limit of the BIN 2.
- 11) Repeat step 5 until the BIN 9 limits are entered. After entering the BIN 9 high limit, the cursor will be automatically moved to the 2nd LOW field. Enter the low limit value of the secondary parameter.
- 12) The cursor will be automatically moved to the 2nd HIGH field. Enter the high limit value of the secondary parameter.

3.8.7 File Manage

Refer to 3.2.8 File Manage

3.8.8 Useful Tools

Clear Table Function allows you to clear all of the limit values. So when you change the limit mode, this function must be used.

Perform the following steps to clear all of bin sorting limits on the LIMIT TABLE SETUP page.

- 1) Move the cursor to the TOOLS field.
- 2) Press **CLEAR TABLE** to clear all of the bin sorting limits.

3.9 LIST SWEEP SETUP page

When you press **LCRZ**, **MORE 1/3** and **LIST SETUP**, the LIST SWEEP SETUP page will be displayed. TH2819A has a list sweep measurement function which permits up to ten test frequencies, oscillator levels, or DC bias points to be measured automatically. On the LIST SWEEP SETUP page, the following control settings of the list sweep measurement can be set. (Each field in parenthesis is used when that control is set.)

- Sweep Mode (MODE)
- Sweep Parameter Selection (FREQ [Hz], LEVEL [V], LEVEL [A], BIAS [V], or BIAS [A])
- Sweep Point Settings (sweep point)
- Limit Parameter Selection (LMT)
- Low/High Limit Values (LOW, HIGH)

There are following fields on this page: <LIST SWEEP SETUP>, MODE, FREQ [Hz] (LEVEL [V],

LEVEL [A], BIAS [V], or BIAS [A]), LMT, LOW/HIGH, FILE, TOOLS and sweep points.

These functions are described in the following paragraphs.

The available fields and softkeys which corresponded to the fields on this page are shown in Figure 3-19 and Figure 3-20.

| | | | | |
|---------------------------------|-----|----------|----------|--------|
| ☐ <LIST SWEEP SETUP> FILE TOOLS | | | | MEAS |
| MODE :SEQ | | | | SETUP |
| FREQ [Hz] | LMT | LOW | HIGH | |
| 1. 00000K | A | 1. 10000 | 1. 20000 | CORREC |
| 2. 00000K | A | 1. 10000 | 1. 20000 | TION |
| 3. 00000K | A | 1. 10000 | 1. 20000 | |
| 4. 00000K | A | 1. 10000 | 1. 20000 | LIMIT |
| 5. 00000K | A | 1. 10000 | 1. 20000 | TABLE |
| 6. 00000K | A | 1. 10000 | 1. 20000 | |
| 7. 00000K | A | 1. 10000 | 1. 20000 | LIST |
| 8. 00000K | A | 1. 10000 | 1. 20000 | SETUP |
| 9. 00000K | A | 1. 10000 | 1. 20000 | |
| 10. 0000K | A | 1. 10000 | 1. 20000 | MORE |
| ☺ Use softkeys to select | | | | 2/3 |

☐ : Field

Figure 3-19 Available Fields on the LIST SWEEP SETUP Page

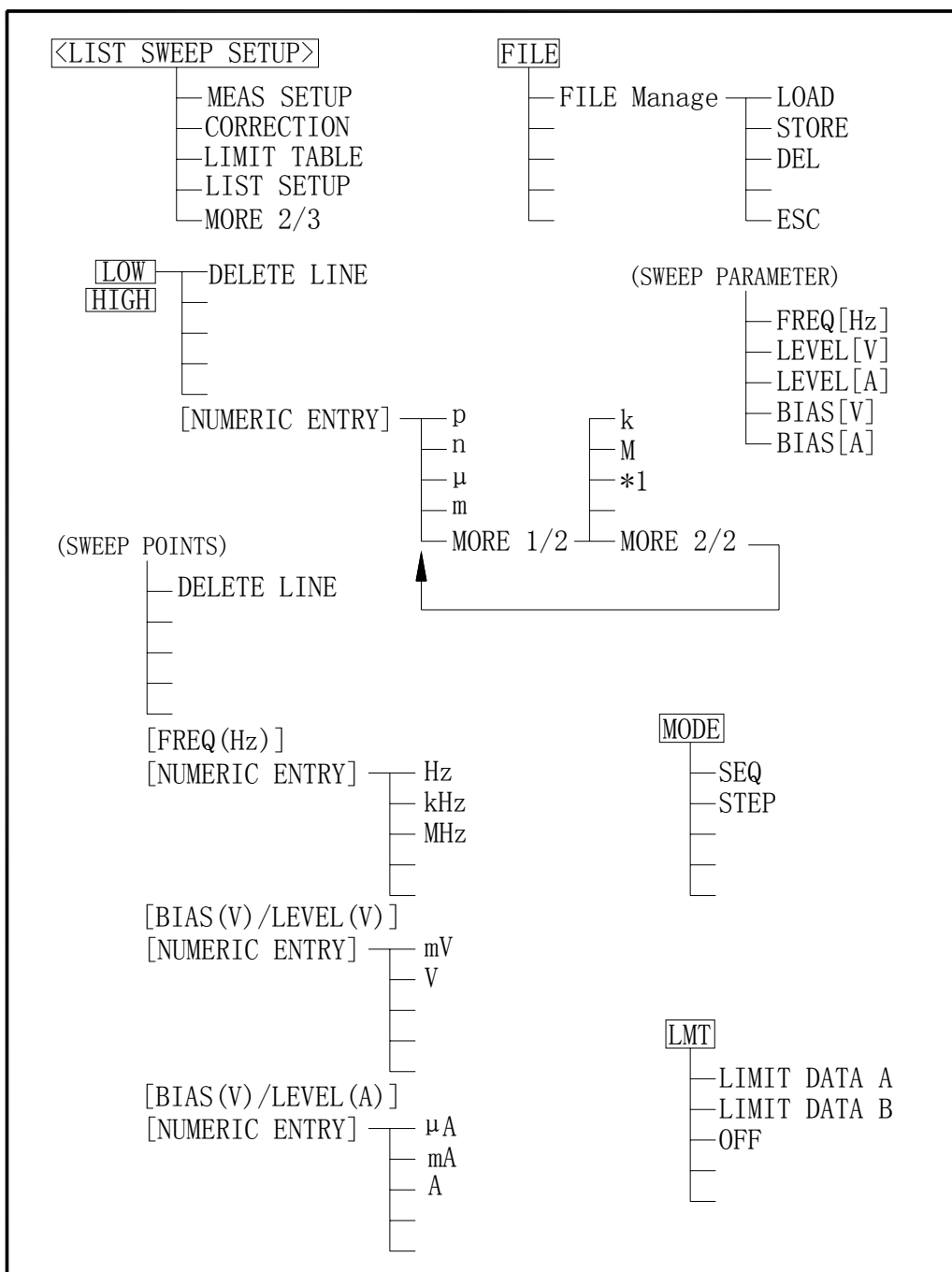

Figure 3-20 Available Softkeys on the LIST SWEEP SETUP Page

3.9.1 Sweep Mode

Th2819A has a List Sweep measurement function which permits up to 10 test frequencies, oscillator levels, or DC bias points to be automatically measured. There are two sweep modes for the list sweep

measurements: sequential (SEQ) mode and step (STEP) mode. In the case of the sequential mode, when TH2819A is triggered once, the device is measured at all sweep points automatically. In the case of the step mode, the sweep point is increased each time when TH2819A is triggered.

Front Panel Operation for Setting the List Sweep Measurement Mode

Perform the following steps to set the list sweep measurement mode to the sequential mode or to the step mode.

- 1) Move the cursor to the MODE field. The following softkeys will be displayed.
 - SEQ
 - STEP
- 2) Select and press a softkey to set the list sweep measurement mode.

3.9.2 List Sweep Parameter

The sweep point parameter for the list sweep measurement can be set to the test frequency, oscillator level, and DC bias. This field allows you to set the parameter of the list sweep measurement.

Front Panel Operation for Setting the List Sweep Parameter

Perform the following steps to set the list sweep parameter.

- 1) Move the cursor to the FREQ [Hz] (LEVEL [V], LEVEL [A], BIAS [V], or BIAS [A]) field the following softkeys will be displayed.
 - FREQ [Hz]
 - LEVEL [V]
 - LEVEL [A]
 - BIAS [V]
 - BIAS [A]
- 2) Select and press a softkey to set the list sweep measurement sweep parameter.

3.9.3 Sweep Points and Limit Mode

The list sweep function permits entry of up to 10 points and measurement limits.

Front Panel Operation for Setting the Sweep Points

Perform the following steps to set the sweep points and measurement limits.

- 1) Move the cursor to the sweep parameter field and set the sweep parameter.
- 2) Move the cursor to the sweep point field.

- 3) Enter the sweep point by using the numeric entry keys. When the one of the numeric entry keys is pressed, the unit softkeys (p, n, μ , m, k, M *1) can be used instead of **ENTER**. When **ENTER** is pressed, the numeric data is entered with the same unit selected last time. When *1 is pressed, the numeric data is entered with the F, H and Ω as the default unit.
- 4) The cursor will move automatically to the LMT field after you enter a sweep point. The following softkeys will be displayed.
 - **LIMIT DATA A**

This softkey is used to set the limit parameter for the primary parameter of the measurement function. When this softkey is pressed, the cursor will automatically move to the LOW field.
 - **LIMIT DATA B**

This softkey is used to set the limit parameter for the secondary parameter of the measurement function. When this softkey is pressed, the cursor will move automatically to the LOW field.
 - **OFF**

This softkey is used to set the list sweep measurement's limit function to OFF for the sweep point. When this softkey is pressed, the cursor will move to the next sweep point field automatically.
- 5) Press the softkey described above to set the limit parameter.
- 6) The cursor will move automatically to the LOW field. (If you pressed **OFF** in the previous step, the cursor will move automatically to the next sweep point field.) Enter the low limit value.
- 7) The cursor will move automatically to the HIGH field. Enter the high limit value using the numeric entry keys. After entering the high limit value, the cursor will move automatically to the next sweep point field. Repeat steps 3 through 7.

3.9.4 File Manage

Refer to 3.2.8 File Manage.

3.9.5 Useful Tools

No tool is provided on LIST SWEEP SETUP

Chapter 4 [SYSTEM] menu key description

This chapter describes the [SYSTEM] menu key. At the same time, the softkey function will be offered for you.

4.1 SYSTEM Menu

System Menu key provides the following two pages.

■ SYSTEM SETUP

The functions on each page are described in the following paragraphs.

4.2 SYSTEM SETUP Page

When you press **[SYSTEM]**, the SYSTEM SETUP Page will be displayed. On this SYSTEM SETUP page, the following control functions can be set from this page. (The field in parenthesis is used to set the control function.)

- LCD Contrast adjustment (LCD CONST)
- BEEPER function ON/OFF (BEEPER)
- ALARM mode (ALARM)
- LANGUAGE selection (LANGUAGE)
- PASS WORD function (PASS WORD)
- BUS MODE selection (BUS MODE)
- BUS Address setup (BUS ADDR)
- Talk only mode ON/OFF (TALK ONLY)
- DC Bias Source mode (BiasSourc)

So there are twelve fields on this page: SYSTEM SETUP, FILE, TOOLS, LCD CONST, BEEPER, ALARM, LANGUAGE, PASS WORD, BUS MODE, BUS ADDR, TALK ONLY and Bias sourc fields. Each field is described in the following paragraphs.

The available fields and the softkeys which correspond to each field on this page are shown in Figure 4-1 and Figure 4-2.

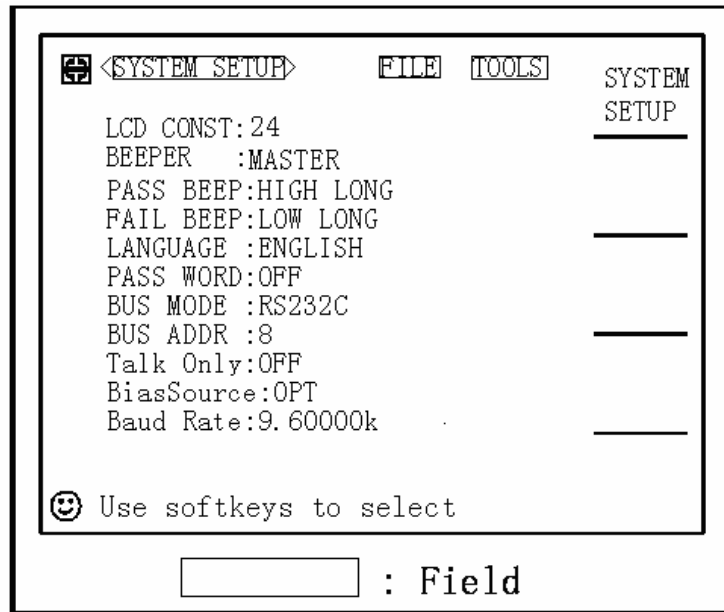

Figure 4-1 Available Fields on the SYSTEM SETUP Page

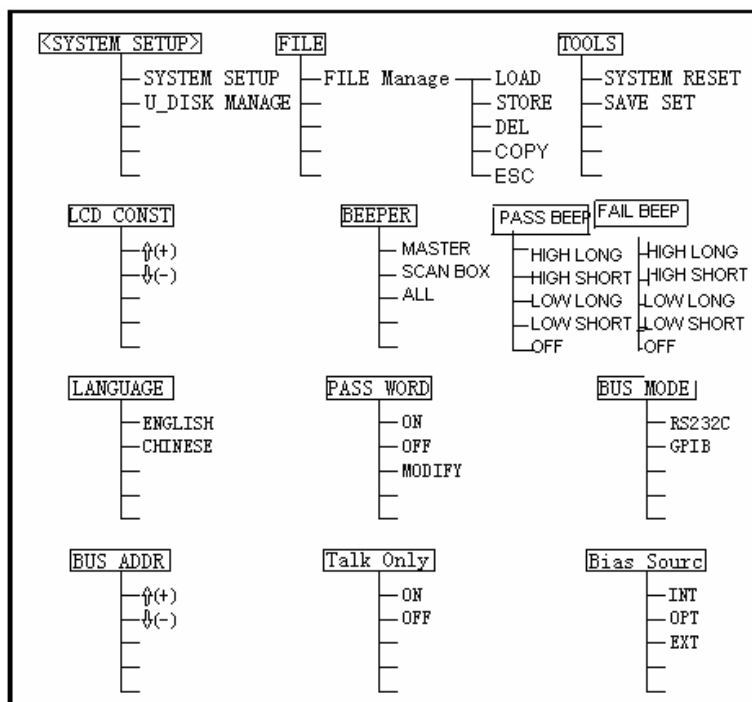

Figure 4-2 Available Softkeys on the SYSTEM SETUP Page

4.2.1 LCD Contrast adjustment

Perform the following steps to adjust the LCD's CONTRAST.

- 1) Move the cursor to the LCD CONST field on the SYSTEM SETUP page. The following softkeys will be displayed in the softkey label area.

- **↑(+)**:this key is used to increase the contrast.
- **↓(-)**:this key is used to decrease the contrast.

- 2) Use the softkeys to adjust the LCD's contrast from 1 to 31 until you get the suitable contrast effect.

4.2.2 BEEPER

This field is used to control and display the alarm sound.

The procedures of the beeper setting are as follows:

Move the curse to beeper field, the software field on the screen will display the keys below:

- **MASTER**

This key is used to select the instrument as the sounder.

- **SCANBOX**

This key is used to select the SCANBOX as the sounder (when TH2819A is connected to the SCANBOX)

- **ALL**

This key is used to select both the instrument and the SCANBOX as the sounders.

4.2.3 Pass beep

This field is used to control and display the alarm sound mode when the comparison result is nice.

Perform the following steps to configure the pass beep:

Move the curse to "PASS BEEP"FIELD. The following softkeys will be displayed:

- **HIGH LONG**

This key is used to select high and long alarm tone.

- **HIGH SHORT**

This key is used to select high and short alarm tone.

- **LOW LONG**

This key is used to select low and long alarm tone.

- **TWO SHORT**

This key is used to select two low and short alarm tones.

- **OFF**

This key is used to select no alarm tone.

Note: the potentiometer is used to adjust the tone of SCANBOX. So when SCANBOX is selected as the beep source, you can select the tone long or short, but you can't select the tone high or low.

4.2.4 FAIL BEEP

This field is used to control and display the alarm sound mode when the comparison result is not good.

Perform the following steps to configure the fail beep:

Move the curse to "FAIL BEEP"FIELD. The softkeys will be displayed, which are the same to the

softkeys in the pass beep above.

4.2.5 LANGUAGE selection

Perform the following steps to select display language.

- 1) Move the cursor to the LANGUAGE field on the SYSTEM SETUP page. The following softkeys will be displayed in the softkey label area.
 - English
 - 中文 (Chinese)
- 2) Use the softkeys to set the display language.

4.2.6 PASS WORD function

TH2819A needs a pass word in the following conditions.

- Turn on the instrument on Welcome page (if pass word ON)
- To cancel the key lock function (if pass word ON)
- Set the pass word function to OFF
- Modify the pass word.

Note: The default pass word for TH2819A is “2819A”.

Perform the following steps to set the PASS WORD:

Move the cursor to the PASS WORD field on the SYSTEM SETUP page. The following softkeys will be displayed in the softkey label area.

- OFF

This softkey is used to close the password protection.

Press OFF, “Input password:” will be displayed in the system information line. Input the correct password, the password function is set to OFF.

- LOCK SYSTEM

This softkey is used to open the protection function, including the files protection and the password protection.

- LOCK FILE

This softkey is used to protect the user’s files.

- **MODIFY**

This softkey is used to modify the password.

(1) Press “MODIFY”, “Input password:” will be displayed in the system information line.

(2) Input the correct password, “New password:” will be displayed in the system information line.

(3) Input the new password, “Confirm new password:” will be displayed in the system information line.

(4) Input the new password again, “Password modify ok” will be displayed in the system information line.

If the new password is wrongly entered, “Password modify fail” will be displayed.

NOTE: the default password is **2819**.

4.2.7 BUS MODE selection

TH2819A provides two types of bus mode, RS232C and GPIB.

Perform the following steps to set the bus mode.

1) Move the cursor to the BUS MODE field on the SYSTEM SETUP page. The following softkeys will be displayed in the softkey label area.

- **RS232C**

- **GPIB**

2) Use the softkeys to set the bus mode.

4.2.8 BUS Address setup

TH2819A provides the bus address range from 1 to 31.

Perform the following steps to set the bus address.

1) Move the cursor to the BUS ADDR field on the SYSTEM SETUP page. The following softkeys will be displayed in the softkey label area.

- **↑(+)**

- **↓(-)**

2) Use the softkeys to set the bus address.

4.2.9 Talk only mode ON/OFF

Perform the following steps to set TH2819A to the Talk Only mode (ON). To set TH2819A to the addressable mode, perform the following steps to set the Talk Only mode to OFF.

- 1) Move the cursor to the TALK ONLY field on the SYSTEM SETUP page. The following softkeys will be displayed in the softkey label area.
 - ON
 - OFF
- 2) Use the softkeys to set the Talk Only mode to ON (Talk only), or to OFF (addressable).

4.2.10 DC Bias Source mode

TH2819A provides three types of DC Bias Source mode INT (internal), OPT (option) and EXT (external).

Perform the following steps to set the DC Bias Source mode.

- 1) Move the cursor to the BiasSourc field on the SYSTEM SETUP page. The following softkeys will be displayed in the softkey label area.
 - INT
 - OPT
 - EXT
- 2) Use the softkeys to set the DC Bias Source mode.

4.2.11 BAUD RATE

This field is used to set the baud rate for RS232 interface of the instrument. The range of the rate is 9.600k to 115.200k.

Perform the following steps to set the baud rate for RS232:

- (1) Move the cursor to the Baud Rate field on the SYSTEM SETUP page. The following softkeys will be displayed in the softkey label area.
 - ↑ (+) This softkey is used to increase the baud rate of the instrument.
 - ↓ (-) This softkey is used to decrease the baud rate of the instrument
- (2) Move the cursor to TOOLS field, Press SAVE SET

4.2.12 File Manage

Refer to 3.2.8 File Manage.

4.2.13 Useful Tools

Front Panel Operation for Useful Tools

Perform the following steps to reset TH2819A and save the system setup.

- 1) Move the cursor to the TOOLS field on the SYSTEM SETUP page. The following softkeys will be displayed.
 - SYSTEM RESET
 - SAVE SET
- 2) Press SYSTEM RESET to reset TH2819A.
- 3) Press SAVE SET to save the system setup page.

Chapter 5 Measurement procedure and examples

This chapter covers basic measurement procedures and examples. It also offers various measurement hints.

5.1 Clear (CORRECTION OPERATION)

To prevent the stray capacitance from disturbing the measurement accuracy, you must do the OPEN/SHORT CORRECTION. You can choose one of the methods below.

5.1.1 Frequency sweep clear

- a) Press [LCRZ], and press the softkey **MORE1/3**. **MEAS SETUP**, **CORRECTION**, **LIMIT TABLE**, **LIST SETUP**, **MORE2/3** will be displayed in the softkey area.
- b) Press **CORRECTION**. The **CORRECTION** page will be displayed.
- c) Move the cursor to **OPEN** field. **ON**, **OFF**, **MEAS OPEN** will be displayed in the softkey area.
- d) Keep the test fixture open, press **MEAS OPEN**, wait until the bottom line prompts "OPEN measurement completed".
- e) Press **ON**, enable the open correction function.
- f) Connect shorting bar (TH26010) to the test fixture.
- g) Move the cursor to **SHORT** field. **ON**, **OFF**, **MEAS SHORT** will be displayed in the softkey area.
- h) Press **SHORT CORRECTION**, wait until the bottom line prompts "SHORT measurement completed".
- i) Press **ON**, enable the short correction function.
- j) Move the cursor to **LOAD** field. **ON** and **OFF** will be displayed in the softkey area.
- k) Press **OFF**. Close the load correction function.
- l) Move the cursor to **FREQ 1** field. **ON**, **OFF**, **MEAS OPEN**, **MEAS SHORT** and **MEAS LOAD** will be displayed in the softkey area.
- m) Press **OFF**, close the dot frequency clear function for frequency 1.
- n) Move the cursor to **FREQ 2** field. **ON**, **OFF**, **MEAS OPEN**, **MEAS SHORT** and **MEAS LOAD** will be displayed in the softkey area.
- o) Press **OFF**, close the dot frequency clear function for frequency 2.
- p) Move the cursor to **FREQ 3** field. **ON**, **OFF**, **MEAS OPEN**, **MEAS SHORT** and **MEAS LOAD** will

be displayed in the softkey area.

- q) Press **OFF**, close the dot frequency clear function for frequency 3.

5.1.2 Dot frequency clear (for single frequency)

Dot frequency clear for single frequency is recommended.

Suppose that the frequency in you test is 5.5KHz.

- a) Press **[LCRZ]**, and press **MORE1/3**. **MEAS SETUP**, **CORRECTION**, **LIMIT TABLE**, **LIST SETUP**, **MORE2/3** will be displayed in the softkey area.
- b) Press the softkey **CORRECTION**. The **CORRECTION PAGE** will be displayed.
- c) Move the cursor to **OPEN** field. **ON**, **OFF** and **MEAS OPEN** will be displayed in the softkey area.
- d) Press **ON**, enable the open correction function.
- e) Move the cursor to **SHORT** field. **ON**, **OFF** and **MEAS SHORT** will be displayed in the softkey area.
- f) Press **ON**, enable the short correction function.
- g) Move the cursor to the **LOAD** field. **ON** and **OFF** will be displayed in the softkey area.
- h) Press **OFF**, close the load correction function.
- i) Move the cursor to **FREQ 1** field. **ON**, **OFF**, **MEAS OPEN**, **MEAS SHORT** and **MEAS LOAD** will be displayed in the softkey area.
- j) Press **ON**, enable the dot frequency clear function for frequency 1.
- k) Press key **[5],[.],[5]**, **+5.5** will be displayed in the bottom line of the screen, and the usable units (Hz, kHz, and MHz) will be displayed in the softkey area. Press the softkey **kHz**, the frequency 1 will be changed to 5.5000 kHz which is the same to the test frequency.
- l) Keep the test fixture open, press the softkey **MEAS OPEN** to perform open correction.
- m) Connect the shorting bar (TH26010) to the test fixture.
- n) Press the softkey **MEAS SHORT** to perform short correction.

5.2 The right connection between the test fixture and the DUT

Generally, any mutual inductance, interference of the test signals, or unwanted residual factors in the connection method incidental to ordinary termination methods will have a significant effect on measurement, especially at high frequency. The TH2819A employs a four-terminal pair measurement configuration that permits easy, stable, and accurate measurement while avoiding the negative influences inherent in the above factors. These are the UNKNOWN Terminals used to connect a four-terminal pair test fixture or test leads for measuring the device under test.

HD: High current drive

HS: High potential sense

LS: Low potential sense

LD: Low current drive

The every test terminal has its own shielding layer.

HD, HS, LD, LS must be connected to the corresponding lead wire of the DUT to make up of the four terminal test.

If you do the test with high accuracy, to use the test fixture is recommended.

No matter you use the test fixture provided by Tonghui Company, Kelvin test leads or the test fixture made by yourself, the following requirement must be met:

- 1) The distributed resistance must be decreased to the minimum, especially when the high resistance DUT is tested.
- 2) The contact resistance must be decreased to the minimum.
- 3) Short correction and open correction can be performed between the two contact points.

Note: 1) When the DUT has the polarity, the high potential terminal should be connected to “+” or HD, HS terminal, the low potential terminal should be connected to “-” or LD, LS terminal on the front panel.

2) Do the discharge before the DUT is tested to avoid the damage to the instrument.

5.3 Eliminate the disturbance of the stray capacitance

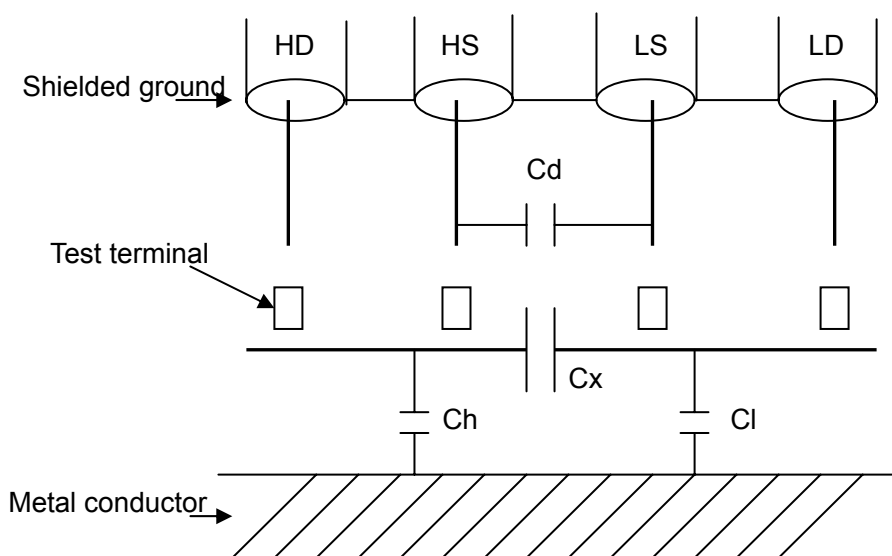

Figure 5-1 the disturb of the stray capacitance

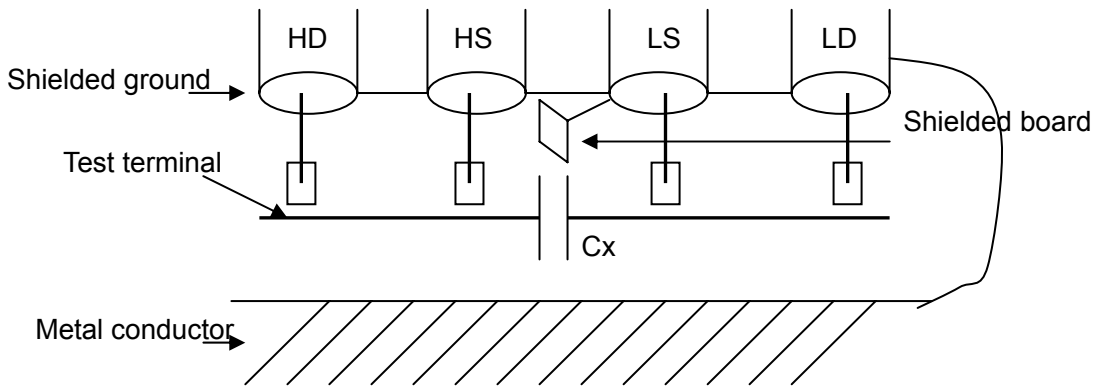

Figure 5-2 the method of eliminating the disturb of the stray capacitance

When the DUT is High Impedance (e.g.: small capacitance), the disturbance of the stray capacitance should not be neglected. In figure 5-1, when there is a conductor board below the DUT, the test result will be error. But when a grounded conductor is placed between the HS and the LS, C_d can be reduced to the smallest. At the same time, if the grounded conductor is placed between the LD and Metal conductor, the effect of the C_h and the C_i will be eliminated.

When the DUT is low impedance (e.g.: small inductance, big capacitance), the main source of the test error is electromagnetic coupling between the test leads. TH2819A employs a four-terminal pair measurement configuration to eliminate the effect of the coupling. Because the current in HD, LD and the one in the shielding terminal are the same size, but the opposite direction, the magnetic fields are eliminated.

5.4 Inductance test example

measurement conditions:

function: Ls-Q

frequency: 5.5kHz

level: 1.5Vrms

internal resistance: 100Ω

Procedures:

1) Turn on the TH2819A.

2) Set the basic parameters:

- a) Press [LCRZ], LCR MEAS DISP page will be displayed.
- b) Move the cursor to FUNC field by using the direction keys on the front panel. The FUNC field displays C_p-D . At this time, C_p-D , C_p-Q , C_p-G , C_p-R_p and MORE 1/6 will be displayed in the softkey area, which is on the right of the screen.

- c) Press MORE 1/6. Cs-D, Cs-Q, Cs-Rs and MORE 2/6 will be displayed.
 - d) Press MORE 2/6. Lp-D, Lp-Q, Lp-G, Lp-Rp and MORE 3/6 will be displayed.
 - e) Press MORE 3/6. Ls-D, Ls-Q, Ls-Rs and MORE 2/6 will be displayed.
 - f) Press Ls-Q to select Ls-Q test function.
 - g) Move the cursor to FREQ. the current frequency displayed is 1.0000kHz.
 - h) Press key[5][.][5], +5.5 will be displayed in the bottom line of the screen. The softkey area will display the usable units (Hz, kHz and MHz). Press kHz, the FREQ field will be changed to 5.5000kHz.
 - i) Move the cursor to LEVEL field. The current level displayed is 1.000V.
 - j) Press[1][.][5]. +1.5 will be displayed in the bottom line of the screen, and the softkey area will display the usable units (mV, V, uA, mA and A). Press ENTER, the level will be changed to 1.5V.
 - k) Press [LCRZ], and then press MORE 1/3, MEAS SETUP page will be displayed.
 - l) Move the cursor to Rsou field. 100Ω and 30Ω will be displayed in the softkey area.
 - m) Press the softkey 100Ω to select 100Ω as the internal resistance of the signal source.
- 3) Connect the test fixture (TH26005) to TH2819A's test terminals.
 - 4) Perform the clear. (To avoid the disturbance of the stray capacitance, you should do OPEN/SHORT CORRECTION. Refer to Dot frequency clear in this chapter.)
 - 5) Insert the test capacitance to test fixture.
 - 6) Perform the measurement.

Press [LCRZ], TH2819A will display LCR MEAS DISP page. TH2819A can test continually and display the test result in the middle of the screen as figure 5-3 shows.

| | | | |
|-----------------------|-------------|-------|------|
| <LCR MEAS DISP> | FILE | TOOLS | MEAS |
| FUNC: Ls-Q | RANGE: AUTO | DISP | |
| FREQ: 5.5000kHz | BIAS: 0.00V | BIN | |
| LEVEL: 1.500V | SPEED: SLOW | NO | |
| | | BIN | |
| | | COUNT | |
| | | LIST | |
| | | SWEEP | |
| | | MORE | |
| Vm: 1.000V | Im: 1.101mA | 1/3 | |
| CORR: OPEN, SHORT | | | |
| Use softkey to select | | | |

Figure 5-3 LCR MEAS DISP page

- 7) If the test result is error evidently, please perform the following steps:
 - (a) Check whether the capacitance is connected to the test fixture reliably
 - (b) Check whether the test fixture is connected to the test terminal of the instrument reliably.
 - (c) Do open correction and short correction again.

Note: when you use frequency sweep open/short correction, the dot frequency correction function

should be OFF. Please refer to 5.1 in this chapter.

5.5 Multi-frequency List sweep for capacitance test

measurement conditions:

function: Cp-D

level:1Vrms

The other parameters are shown in table 5-1:

Table 5-1 the related parameters of the capacitance test

| frequency | Compared parameter | upper limit | lower limit |
|-----------|--------------------|-------------|-------------|
| 1kHz | Cp | 325.0nF | 333.0nF |
| 10kHz | D | 0.0001 | 0.0003 |
| 100kHz | D | 0.0060 | 0.0100 |

Beep: HIGH

Alarm mode: out

Procedures:

1) Turn on the TH2819A.

2) Set the basic parameters:

- a) Press [LCRZ], LCR MEAS DISP page will be displayed.
- b) The FUNC field is Cp-D, the LEVEL field is 1.000V. At the same time, MEAS DISP, BIN NO, BIN COUNT, LIST SWEEP and MORE 1/3 will be displayed in the softkey area.
- c) Press MORE 1/3. MEAS SETUP, CORRECTION, LIMIT TABLE, LIST SETUP and MORE 2/3 will be displayed in the softkey area.
- d) Press LIST SETUP. LIST SWEEP SETUP page will be displayed.
- e) Move the cursor to (sweep parameter) field. The field displays FREQ [HZ].
- f) Press [↓]. Move the cursor to the parameter area of sweep point 1. The parameter area displays .
- g) Press [1], +1 will be displayed in the bottom line of the screen. The softkey area will display the usable units (Hz, kHz and MHz). Press kHz. The value of this field will be changed to 1.0000k.
- h) Press [↔], move the cursor to the LMT field of sweep point. The field displays . The softkey area will display LIMIT DATA A, LIMIT DATA B and OFF.
- i) Press LIMIT DATA A to select the main compared parameter Cp, the LMT field will display A, the cursor will be moved to the LOW field automatically.
- j) Press [3][2][5], +325 will be displayed in the bottom line of the screen. The usable units (p, n, u, m and MORE 1/2) will be displayed in the softkey area. Press n, the value of the field will be changed to 325.000n. The cursor will be moved to the HIGH field of the sweep point 1 automatically.
- k) Press [3][3][3], +333 will be displayed in the bottom line of the screen. The usable units (p, n, u, m and MORE 1/2) will be displayed. Press n, the value of this field will be changed to 333.000n. The cursor will be moved to the parameter area of the sweep point 2.
- l) Press [10], +10 will be displayed in the bottom line of the screen. The usable units (Hz, kHz

and MHz) will be displayed in the softkey area. Press kHz, the value of this field will be changed to 10.0000k.

- m) Press [↔]. Move the cursor to the LMT field of the sweep point 2. Current field displays , the softkey area will display LIMIT DATA A, LIMIT DATA B and OFF.
- n) Press LIMIT DATA B to select the secondary compared parameter D. The field will display , the cursor will be moved to the LOW field of the sweep point 2 automatically.
- o) Press [0].[0][0][0][1], +0.0001 will be displayed in the bottom line of the screen. The usable units (p, n, μ, m and MORE 1/2) will be displayed in the softkey area. Press MORE 1/2. k, M, *1 and MORE 2/2 will be displayed. Press *1, the value of this field will be changed to 100.000μ. The cursor will be moved to the HIGH field of the sweep point 2 automatically.
- p) Press [0].[0][0][0][3], +0.0003 will be displayed in the bottom line of the screen, the usable units (k, M, *1 and MORE 2/2) will be displayed in the softkey area. Press *1, the value of the field will be changed to 300.000μ. The cursor will be moved to the parameter area of the sweep point 3.
- q) According to steps l to p, Input the parameters of sweep point 3 in turn: 100 kHz, B, 0.0060 and 0.0100.

3) Setting for alarm

- (a) Press [SYSTEM]. The SYSTEM SETUP page will be displayed.
- (b) Move the cursor to beep field. The current field displays LOW. OFF, LOW and HIGH will be displayed in the softkey area.
- (c) Press HIGH to select beep with high sound
- (d) Move the cursor to ALARM MODE field. The current field displays OUT

4) Connect the test fixture (TH26005) to TH2819A's test terminals.

5) Perform the clear. (To avoid the disturbance of the stray capacitance, you should do OPEN/SHORT CORRECTION by referring to Dot frequency clear in this chapter.)

6) Insert the capacitance to test fixture.

7) Perform the following measurement.

Press [LCRZ], and press LIST SWEEP. TH2819A will display LIST SWEEP DISP page. The continually sweep test will be performed. The test and compared result will be displayed. The beep will sound when the compared result is H (greater than the high) and L (less than the low). Figure 5-4 shows the LIST SWEEP DISP page.

8) If the test result is error evidently, please perform the following steps:

- (a) Check whether the capacitance is connected to the test fixture reliably
- (b) Check whether the test fixture is connected to the test terminal of the instrument reliably.
- (c) Do open correction and short correction again.

Note: when you use frequency sweep open/short correction, the dot frequency correction function should be OFF. Please refer to 5.1 in this chapter.

| <LIST SWEEP DISP>FILE | | | | TOOLS | MEAS |
|------------------------|----------|---------|--|-------|-------|
| MODE:SEQ | | | | | DISP |
| FREQ[Hz] | Cp[F] | D [] | | CMP | BIN |
| 1.00000k | 326.335n | 0.00039 | | | NO |
| 10.0000k | 326.353n | 0.00060 | | H | BIN |
| 100.000k | 326.655n | 0.00439 | | L | COUNT |
| | | | | | LIST |
| | | | | | SWEEP |
| | | | | | MORE |
| | | | | | 1/3 |
| Use softkeys to select | | | | | |

Figure 5-4 the LIST SWEEP DISP page

5.6 Operation example for load correction

Procedures:

Suppose the test conditions are below:

frequency:100kHz

standard Cp:11nf

standard D:0.0005

- Press [LCRZ], and then press **MORE 1/3**. **MEAS SETUP**, **CORRECTION**, **LIMIT TABLE**, **LIST SETUP** and **MORE 2/3** will be displayed in the softkey area.
- Press the softkey **CORRECTION**. **CORRECTION** page will be displayed.
- Move the cursor to OPEN field. **ON**, **OFF** and **MEAS OPEN** will be displayed in the softkey area.
- Press **ON** to enable the open correction.
- Move the cursor to SHORT field. **ON**, **OFF** and **MEAS SHORT** will be displayed in the softkey area.
- Press **ON** to enable the short correction.
- Move the cursor to LOAD field. **ON** and **OFF** will be displayed in the softkey area.
- Press **ON** to enable the load correction.
- Move the cursor to FUNC field. The current field will display **Cp-D**. **Cp-D**, **Cp-Q**, **Cp-G**, **Cp-Rp** and **MORE 1/6** will be displayed in the softkey area.
- Press **Cp-D** to select Cp-D.
- Move the cursor to FREQ 1 field. **ON**, **OFF**, **MEAS OPEN**, **MEAS SHORT** and **MEAS LOAD** will be displayed in the softkey area.
- Press **ON** to enable the dot frequency correction for FREQ 1.
- Press [1][0][0], +100 will be displayed in the bottom of the screen, the usable units(**Hz**, **kHz** and **MHz**) will be displayed. Press **kHz**. The value of FREQ1 will be changed to 100.000kHz which is the same to test frequency.
- Move the cursor to REF A field below FREQ1. Press [1][1], +11 will be displayed in the bottom line of the screen. The usable units (**p**, **n**, **μ**, **m** and **MORE 1/2**) will be displayed in the softkey area. Press **n**. the value of this field will be changed to 11.0000 nF .
- Move the cursor to B: field below FREQ 1. Press [0][.][0][0][5], +0.0005 will be displayed in the bottom line of the screen, the usable units (**p**, **n**, **μ**, **m** and **MORE 1/2**) will be displayed in the softkey area. Press *1, the value of this field will be changed to 0.00050.
- Move the cursor to FREQ 1 field. **ON**, **OFF**, **MEAS OPEN**, **MEAS SHORT** and **MEAS LOAD** will be displayed in the softkey area.
- Keep the test fixture open, and keep your hands and other disturbance source far from the test

fixture. Press **MEAS OPEN** to perform open correction.

- (r) Insert the shorting bar (TH26010) to the test fixture to ensure the shorting bar and the test fixture contact close.
- (s) Press the softkey **MEAS SHORT** to perform short correction.
- (t) Insert the standard capacitance to the test fixture.
- (u) Press the softkey **MEAS LOAD** to perform load correction.

Note:

- (a) The displayed softkey information may be not identical to the one described in this book because the software version is different.
- (b) Load correction is effective to the instrument with the same specification. If the specification is changed, the load correction should be done again.

Chapter 6 Performance and measurement

This chapter describes the performance of TH2819A. The related parameters for TH2819A are illuminated.

6.1 Measurement function

6.1.1 Measurement parameter and sign description

C: Capacitance L: Inductance
 R: Resistance Z: Impedance Y: Admittance
 X: Reactance B: susceptance G: conductance
 D: dissipation θ : phase angle Q: quality factor
 DCR: DC resistance

6.1.2 Test combination

Eleven test parameters and Lk can be combined as the following methods:

Table 6-1 the combination methods for the test parameters

| | | | | |
|----------------------|--------------------------------------|-----------------|---|---|
| Main parameter | Z, Y | L, C | R | G |
| Auxiliary parameters | θ (degree), θ (radian) | D, Q, RS, RP, G | X | B |

Note: DCR has no test combination

6.1.3 Math operation

$$\Delta ABS=R-S;$$

$$\Delta\%=(R-S)/S*100\%.$$

(R: test value S: standard value)

6.1.4 Equivalent mode

Parallel, serial

6.1.5 Range

Auto, manual (hold, increase and decrease)

6.1.6 Trigger

Inner, outside, manual

Inner: the DUT is tested continually and the result is displayed.

Manual: Press "START" on the panel to perform the test once and the result is displayed. At the other time, the instrument is on the waiting state.

Outside: when the instrument HANDLER interface receives the "START" signal, one test is performed, and then the instrument is on the waiting state.

6.1.7 Delay time

0-60 s is programmable stepped by 1ms.

6.1.8 The unknown terminal

HD: High current drive

HS: High potential sense

LS: Low potential sense

LD: Low current drive

6.1.9 Measurement speed

$f \geq 1$ kHz: Fast: approximately 30 times/s (32ms/time)

Medium: approximately 10 times/s(90 ms/time)

Slow: approximately 1.5 times/s(650ms/time)

The medium speed and the fast speed will be reduced when the frequency is slower than 1kHz.

6.1.10 Average

1 to 255 programmable

6.1.11 Display digits

6 digits, the maximum is 999999.

6.2 Test signal

6.2.1 Test signal frequency

test signal: sine wave, the accurate of the frequency: 0.02%.

the range of the test frequency: 20~200 kHz

the minimum resolution: 0.01Hz

6.2.2 Signal mode

normal: test the voltage by programming in the MEAS DISP page. The voltage in the unknown terminal may be lower than the set one according to the tested resistance.

constant voltage: the DUT voltage is consistent with the set voltage by adjusting the internal voltage.

6.2.3 The test signal level

Table 6-2 the test level of the signal

| | mode | range | accurate | step |
|---------|----------|----------------------------|---|------|
| voltage | normal | 5mVRMS—2VRMS | $\pm (10\% \times \text{set value} + 2\text{mV})$ | 1mV |
| | constant | 5mVRMS—1VRMS | $\pm (6\% \times \text{set value} + 2\text{mV})$ | |
| current | Normal | 50 μ ARMS —20mARMS | $\pm (10\% \times \text{set value} + 10\mu\text{ARMS})$ | 1mV |
| | constant | 100 μ ARMS —10mARMS | $\pm (6\% \times \text{set value} + 10\mu\text{ARMS})$ | |

6.2.4 The output impedance

30 Ω 、100 $\Omega \pm 5\%$

6.2.5 The monitor for test signal level

Table 6-3 the monitor for the test signal level

| mode | range | accurate |
|---------|--------------------------------|--|
| voltage | 5mVRMS—2VRMS | $\pm (3\% \times \text{Result} + 0.5\text{mV})$ |
| | 0.01mVRMS—5mVRMS | $\pm (12\% \times \text{Result} + 0.1\text{mV})$ |
| current | 50 μ ARMS—20mARMS | $\pm (3\% \times \text{Result} + 5\mu\text{A})$ |
| | 0.001 μ ARMS—50 μ ARMS | $\pm (12\% \times \text{Result} + 1\mu\text{A})$ |

6.2.6 The maximum range of the test and display

Table 6-4 the range of the test and the display

| parameters | the test and display range |
|-------------|----------------------------|
| L、Lk | 0.01nH ~ 99.9999kH |
| C | 0.00001pF ~ 9.99999F |
| R、X、Z、DCR | 0.01mΩ ~ 99.9999MΩ |
| Y、B、G | 0.01nS ~ 99.9999S |
| D | 0.00001 ~ 99999.9 |
| Q | 0.01 ~ 99999.9 |
| θ | Deg -179.999°~179.999° |
| | Rad -3.14159 ~ 3.14159 |
| Turns Ratio | 1: 0.01—100: 1 |

6.2.7 The test voltage for DC resistance

1.5 VDC (when the test terminal is open)

Accurate: ±5%

The internal resistance: 30Ω±5%

6.2.8 The internal DC voltage bias

0V, 1.5VDC, 2VDC are optional

The setting accurate: ±5% (1.5V, 2V)

6.3 The test accuracy

The test accuracy includes the test stability, the temperature coefficient, the linear degree, the test repetition and correction interpolating error.

Check the test accuracy under the conditions below:

- ✓ The preheating time: ≥30 minutes
- ✓ The test cable length: 0m, 1m
- ✓ Do the open/short correction correctly.
- ✓ DC bias is OFF.
- ✓ The range of the instrument is AUTO to select the right range.

6.3.1 The accuracy of |Z|、|Y|、L、C、R、X、G、B

The accuracy of |Z|,|Y|,L,C,R,X,G,B is Ae.

$$Ae = \pm[A + (Ka + Kb + Kc) \times 100 + Kd + Kf] \times Ke \quad [%]$$

(A: basic accuracy(in figure 6-1)

Ka: resistance rate factor(in table 6-1)

Kb: resistance rate factor(in table 6-1)

Kc: correction interpolating factor(in table 6-2)

Kd: the cable length factor(in table 6-4)

Ke: temperature factor(in table 6-5)

Kf: correction facton (if no added, Kf=0; if added, Kf=0.2))

The condition when you use the L, C, X, B accuracy: D_x (The test value of D) ≤ 0.1

The condition when you use the R, G accuracy: Q_x (the test value of Q) ≤ 0.1

If $D_x \geq 0.1$, $A_e = A_e * \sqrt{1 + D_x^2}$ (for L,C,X and B)

If $Q_x \geq 0.1$, $A_e = A_e * \sqrt{1 + Q_x^2}$ (for R and G)

The G accuracy can be used only when the test method is G-B combination.

6.3.2 The D accuracy

The D accuracy is D_e .

$$D_e = \pm \frac{A_e}{100}$$

The above expression only can be used when $D_x \leq 0.1$.

When $D_x > 0.1$, $D_e = D_e * (1 + D_x)$

6.3.3 The Q accuracy

The Q accuracy is Q_e .

$$Q_e = \pm \frac{Q_x \times D_e}{1 + Q_x \times D_e}$$

Q_x : the test value of Q

D_e : the D accuracy

Condition for being used: $Q_x \times D_e < 1$

6.3.4 The θ accuracy

The θ accuracy is θ_e .

$$\theta_e = \frac{180}{\pi} \times \frac{A_e}{100} \quad \text{s[deg]}$$

6.3.5 the G accuracy

The G accuracy is G_e .

When D_x (the test value of D) ≤ 0.1 :

$$G_e = B_x \times D_e \quad [S]$$

$$sB_x = 2\pi f C_x = \frac{1}{2\pi f L_x}$$

B_x: the test value of B [S].

C_x: the test value of C [F].

L_x: the test value of L [H].

D_e: the D accuracy.

f: the test frequency.

The above expression only can be used in Cp-G combination and Lp-G combination.

6.3.6 The R_p accuracy

When D_x (the test value of D) ≤ 0.1:

$$R_p = \pm \frac{R_{px} \times D_e}{D_x \mu D_e} \quad [\Omega]$$

R_{px}: the test value of R_p

D_x: the test value of D

D_e: the D accuracy.

6.3.7 The R_s accuracy

The R_s accuracy is R_{se}.

When D_x (the test value of D) ≤ 0.1:

$$R_{se} = X_x \times D_e \quad [\Omega]$$

$$X_x = 2\pi f L_x = \frac{1}{2\pi f C_x}$$

X_x: the test value of X.

C_x: the test value of C [F].

L_x: the test value of L [H].

D_e: the D accuracy.

f: the test frequency.

6.3.8 The accuracy factor

Figure 6-1 shows the test accuracy A.

In figure 6-1, select the minimum value in the boundary. The method of selecting the basic accuracy of A is below:

0.05---when $0.4V_{rms} \leq V_s \leq 1.2V_{rms}$, the test speed is A of the medium, the slow or the fast.

0.1---when $0.4V_{rms} \leq V_s \leq 1.2V_{rms}$, the test speed is A.

When $V_s < 0.4V_{rms}$ or $V_s > 1.2V_{rms}$, the method of the computation for A is: to choose the A according to the current speed, to choose the accuracy correction factor A_r according to the current test signal

level (in figure 6-2).

$A=A \cdot A_e$; (V_s is the test signal level.)

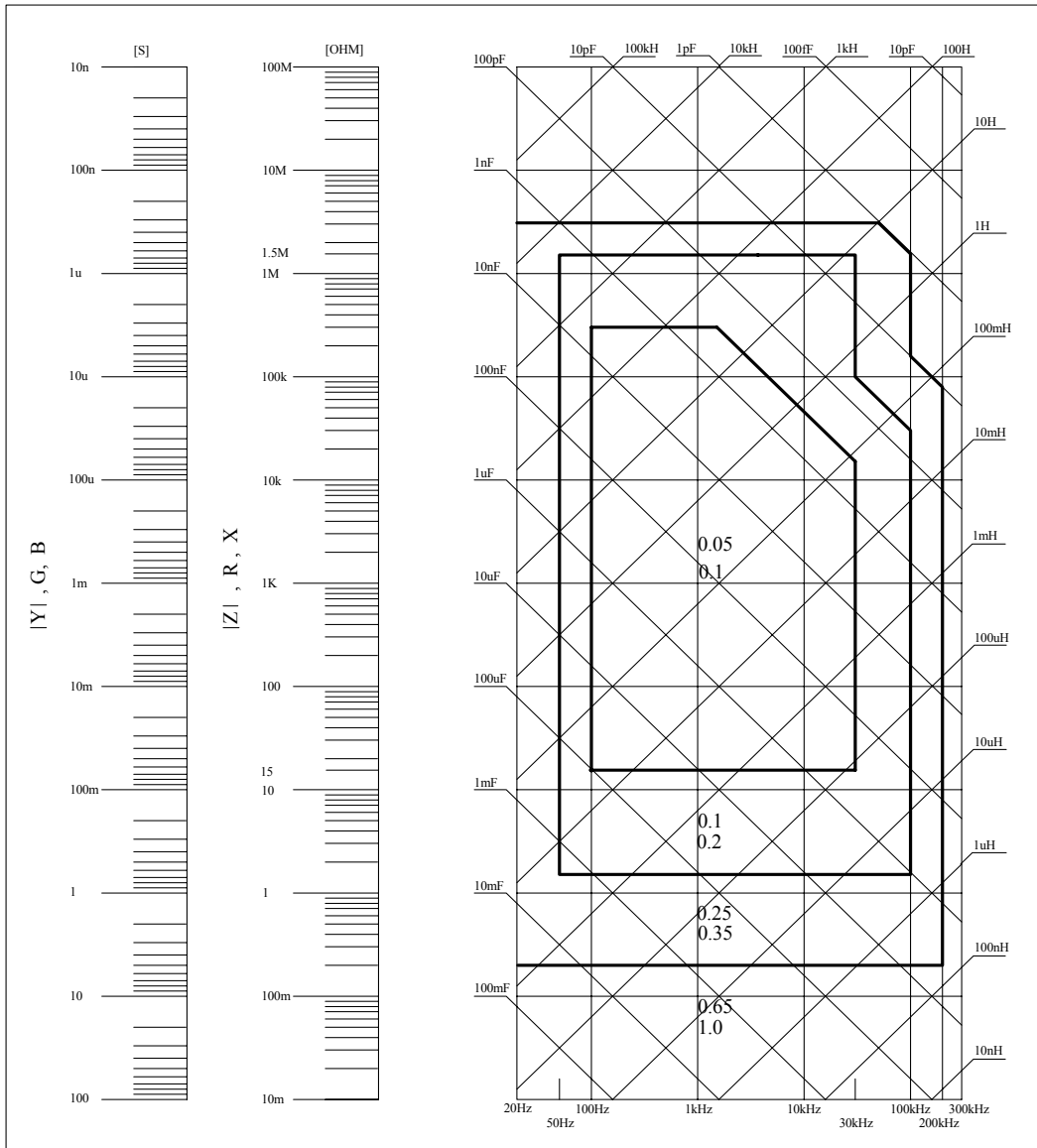

Figure 6-1 the test accuracy A

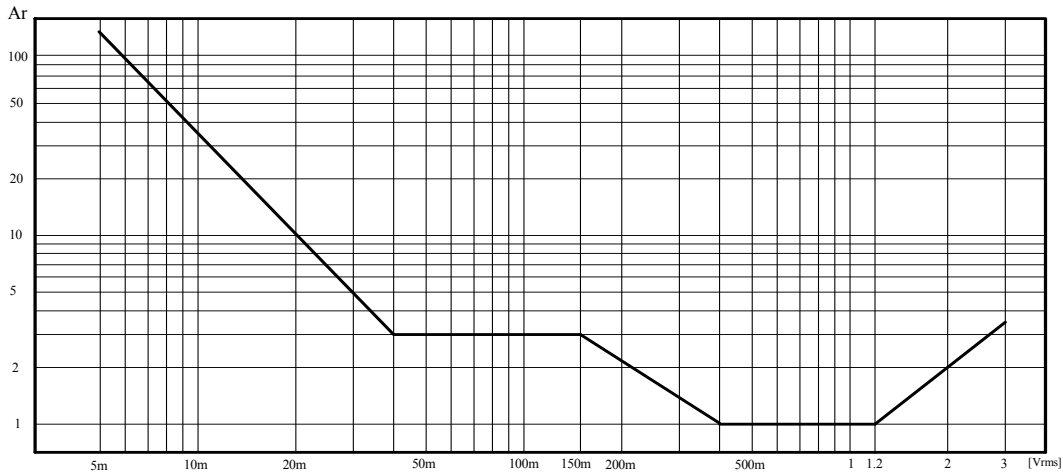

Figure 6-2 the correction curve of the basic accuracy

Table 6-5 the resistance rate factor Ka, Kb

| speed | frequency | Ka | Kb |
|----------------|--|---|--|
| medium slow | $f_m < 100\text{Hz}$ z | $(\frac{1 \times 10^{-3}}{ Z_m })(1 + \frac{200}{V_s})(1 + \sqrt{\frac{100}{f_m}})$ | $ Z_m (1 \times 10^{-9})(1 + \frac{70}{V_s})(1 + \sqrt{\frac{100}{f_m}})$ |
| | $100\text{Hz} \leq f_m \leq 100\text{kHz}$ | $(\frac{1 \times 10^{-3}}{ Z_m })(1 + \frac{200}{V_s})$ | $ Z_m (1 \times 10^{-9})(1 + \frac{70}{V_s})$ |
| | $100\text{kHz} < f_m \leq 200\text{kHz}$ | $(\frac{1 \times 10^{-3}}{ Z_m })(2 + \frac{200}{V_s})$ | $ Z_m (3 \times 10^{-9})(1 + \frac{70}{V_s})$ |
| fast | $f_m < 100\text{Hz}$ z | $(\frac{2.5 \times 10^{-3}}{ Z_m })(1 + \frac{400}{V_s})(1 + \sqrt{\frac{100}{f_m}})$ | $ Z_m (2 \times 10^{-9})(1 + \frac{100}{V_s})(1 + \sqrt{\frac{100}{f_m}})$ |
| | $100\text{Hz} \leq f_m \leq 100\text{kHz}$ | $(\frac{2.5 \times 10^{-3}}{ Z_m })(1 + \frac{400}{V_s})$ | $ Z_m (2 \times 10^{-9})(1 + \frac{100}{V_s})$ |
| | $100\text{kHz} < f_m \leq 200\text{kHz}$ | $(\frac{2.5 \times 10^{-3}}{ Z_m })(2 + \frac{400}{V_s})$ | $ Z_m (6 \times 10^{-9})(1 + \frac{100}{V_s})$ |

f_m : the test frequency [Hz]

the DUT resistance [Ω]

the test signal level [mVrms]

When the resistance is less than 500Ω, Ka should be used, but Kb is useless.
 When the resistance is more than 500Ω, Kb should be used, but Ka is useless.

Table 6-6 correction interpolating factor Kc

| | |
|-----------------------------|--------|
| Test frequency | Kc |
| Direct correction frequency | 0 |
| Other frequency | 0.0003 |

Table 6-7 direct correction frequency

| | | | | | | | | | | |
|-----|-----|-----|-----|-----|-----|-----|-----|-----|-----|-------|
| | | | 20 | 25 | 30 | 40 | 50 | 60 | 80 | [Hz] |
| 100 | 120 | 150 | 200 | 250 | 300 | 400 | 500 | 600 | 800 | [Hz] |
| 1 | 1.2 | 1.5 | 2 | 2.5 | 3 | 4 | 5 | 6 | 8 | [kHz] |
| 10 | 12 | 15 | 20 | 25 | 30 | 40 | 50 | 60 | 80 | [kHz] |
| 100 | 120 | 150 | 200 | 250 | 300 | | | | | [kHz] |

(There are 43 points in table 6-7, TH2819X has no 250kHz, 300kHz.)

Table 6-8 the cable length factor Kd

| The test signal level | The cable length | | |
|-------------------------|------------------|---------------------------------------|-------------------------------------|
| | 0m | 1m | 2m |
| ≤1.5Vrms | 0 | $2.5 \times 10^{-4} (1+50 \times fm)$ | $5 \times 10^{-4} (1+50 \times fm)$ |
| >1.5Vrms | 0 | $2.5 \times 10^{-3} (1+16 \times fm)$ | $5 \times 10^{-3} (1+50 \times fm)$ |
| fm: test frequency[MHz] | | | |

Table 6-9 temperature factor Ke

| temperature (°C) | 5 | | 8 | | 18 | | 28 | | 38 | |
|------------------|---|---|---|--|----|--|----|--|----|---|
| Ke | 6 | 4 | | | 2 | | 1 | | 2 | 4 |

6.3.9 The DCR accuracy

$$A(1+Rx/5M\Omega+16m\Omega/Rx)[\%] \pm 0.2m\Omega$$

When the test speed is medium or slow, A=0.25;

When the test speed is fast, A=0.5

Rx: the test resistance

6.3.10 The Lk accuracy

The inductance L accuracy +0.2%.

6.3.11 The Turns Ratio accuracy

$$\pm At \times Ar (1 + 1\Omega/Zp + 1/Q) [\%] \pm 0.002$$

fast: AT = 0.5

medium、slow: AT = 0.25

Zp: the resistance of the primary inductance.

Ar: the correction value of the test signal in [figure 6-2](#).

This accuracy index can be used under the condition that the coupling factor is 1 or close to 1.

6.4 Safety requirement

6.4.1 insulation resistance

Referring to the working condition, the insulation resistance of the power terminal and the case should not be less than 50MΩ.

Under the damp and heat condition, the insulation resistance should not be less than 2 MΩ.

6.4.2 insulation intension

Referring the working condition, the power terminal and the case should can load the AC voltage with 50Hz in frequency and 1.5kV in rated voltage for 1 minute, and should have no breakdown and arcing.

6.4.3 Leakage current

The leakage current should not be more than 3.5mA (the AC effective value).

6.5 The EMC requirement

The transient sensitivity of the instrument power meets the GB6833.4.

The conduction sensitivity of the instrument meets the GB6833.6.

The radiated interference of the instrument meets the GB6833.10.

6.6 Performance test

6.6.1 Working condition

The test should be done referring to the condition described in chapter 1. we test the main performance. The other performance (e.g.: the parameter of the transformer) can be tested by yourself referring to the condition described in chapter 1.

6.6.2 The experiment instruments

The experiment instruments are shown in table 6-10

| NO | The instrument name | requirement | |
|----|--|---------------------|--------------------------------------|
| 1 | Standard capacitance | 100pF | 0.02% (the loss D has been known) |
| | | 1000pF | |
| | | 10000pF | |
| | | 10nF | |
| | | 0.1uF | |
| | | 1uF | |
| 2 | AC standard resistor | 10Ω | 0.02% |
| | | 100Ω | |
| | | 1kΩ | |
| | | 10kΩ | |
| | | 100kΩ | |
| 3 | DC standard resistor | 0.1Ω | 0.02% |
| | | 1Ω | |
| | | 10Ω | |
| | | 100Ω | |
| | | 1kΩ | |
| | | 10kΩ | |
| | | 100kΩ | |
| 4 | Standard capacitance | 100μH | 0.02% |
| | | 1mH | |
| | | 10mH | |
| | | 100mH | |
| 5 | Frequency meter | (0~1000) MHz | |
| 6 | digital multimeter | 0.5% | |
| 7 | Insolation resistance meter | 500V 10 levels | |
| 8 | withstanding voltage and leakage meter | 0.25kW (0~500) V | |

6.6.3 Check the Function

The keys, the display and the terminals can work normally. The other functions are right.

6.6.4 The test signal level

When the test signal level is tested, the digital multimeter is used. Adjust the range of the multimeter to AC, connect one test stick to the HCUR terminal of the instrument, and the other to the ground terminal. Change the level to 20mv, 100mv, 200mv, 1V and 2 V in turn, the test result must meet the requirement described in this chapter.

6.6.5 frequency

Connect the ground terminal of the frequency meter to that of the instrument, and the test terminal of the frequency meter to the HCUR terminal of the instrument. Change the frequency to 20Hz, 100Hz, 1kHz, 10kHz, 100kHz and 200kHz in turn. The test result must meet the requirement described in this chapter.

6.6.6 The test accuracy

The main test parameters: R, L, C, D. the other parameters can be acquired from the parameters above.

6.6.7 The capacitance C and the loss D accuracy

function: Cp-D
the test frequency: 100Hz ,1kHz ,10kHz,100kHz
level: 1V
range: AUTO
bias: 0V
speed: slow

Short correction and open correction should be done before the test. Connect the standard capacitance (100pF, 1000pF, 10000pF, 10nF, 10nF, 0.1uF and 1uF) to the test fixture. Change the test frequency. The capacitance error between the test result and the standard value must be in the range of the C accuracy. The error of the loss D must be in the range of the D accuracy referring to this chapter.

6.6.8 The inductance L accuracy

Test condition:
Function: Ls-Q
Test frequency: 100Hz , 1kHz ,10kHz and 100kHz
Level: 1V
Range: AUTO
Bias: 0V
Speed: slow

Short correction and open correction should be done before the test. Connect the standard inductance (100μH, 1mH, 10mH and 100mH) to the test fixture. Change the test frequency. The error between the test result and the standard value must be in the range of the L accuracy referring to this chapter.

6.6.9 The resistance Z accuracy

Test condition:

Function: Z- θ
Test frequency: 100Hz, 1kHz ,10kHz and 100kHz
Level: 1V
Range: AUTO
Bias: 0V
Speed: slow

Short correction and open correction should be done before the test. Connect the standard resistor (10 Ω , 100 Ω , 1k Ω , 10k Ω , and 100k Ω) to the test fixture. Change the test frequency. The error between the test result and the standard value must be in the range of the |Z| accuracy referring to this chapter.

6.6.10 The DCR accuracy

Test condition:
Function: DCR
Test frequency: -----
Level: -----
Range: AUTO
Bias: -----
Speed: slow

Short correction and open correction should be done before the test. Connect the standard resistor (0.1 Ω , 1 Ω , 10 Ω , 100 Ω , 1k Ω , 10k Ω , and 100k Ω) to the test fixture. The error between the test result and the standard value must be in the range of the DCR accuracy referring to this chapter.

Chapter 7 Remote control

This chapter provides a description of the remote control system. The RS232C interface and the CPIOB interface on TH2819A are illuminated.

7.1 TH2819A RS232C interface

RS232 interface is asynchronous serial communication interface

Like the most serial interface used in the world, the serial interface on TH2819A doesn't meet RS-232 strictly, but provides one set shown in table 7-1.

Table 7-1 TH2819A RS232 interface

| signal | abbreviate | pin number |
|--------------|------------|------------|
| Send data | TXD | 2 |
| Receive data | RXD | 3 |
| Ground | GND | 5 |

The connection between the TH2819A and the computer is shown in figure 7-1:

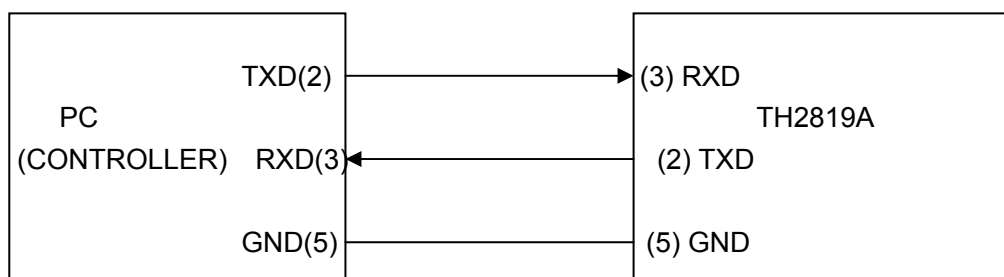

Figure 7-1 the connection between the TH2819A and the PC

Figure 7-1 shows that the pin definition of the TH2819A for serial interface is different from that of IBM AT PC. You can buy the cable for the serial interface from Tonghui Company.

The baud rate can be selected from 9600 to 115200. The frame has no parity, 8 data bits and 1 stop bit.

The data exchange with software is used in TH2819A to avoid losing the data. The procedures of the data exchange are below:

PC sends "AA" to the instrument before sending one command to the instrument.

When the PC receives "CC" sent by the instrument, PC begins to send the command string.

When the string ends, PC sends "0A" as the end char.

Because the speed of PC is faster than that of the instrument, TH2819A only sends data, but doesn't use the data exchange method with the software.

You should pay attention to the methods above when you design the control program.
 If you want to know the data format from the instrument to PC, please refer to chapter 8.

7.2 TH2819A GPIB(optional)

GPIB (General Purpose Interface Bus) is an interface standard for connecting computers and the peripherals, which supports the IEEE 488.2. The GPIB interface allows you to control the TH2819A from an external computer. The computer sends commands and instructions to the TH2819A and receives data sent from the TH2819A via the GPIB.

If you use the GPIB on TH2819A, you should pay attention to the following points:

- (1) The length of the cable for bus system should not be more than 2 m, and the total length of the cable should not be more than 20 m.
- (2) 15 test instruments can be connected to the same bus at most.
- (3) To add only 4-back-connector to one instrument is recommended.

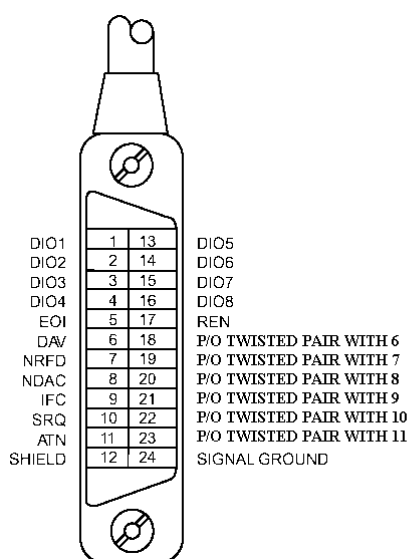

Figure 7-2 the GPIB connector

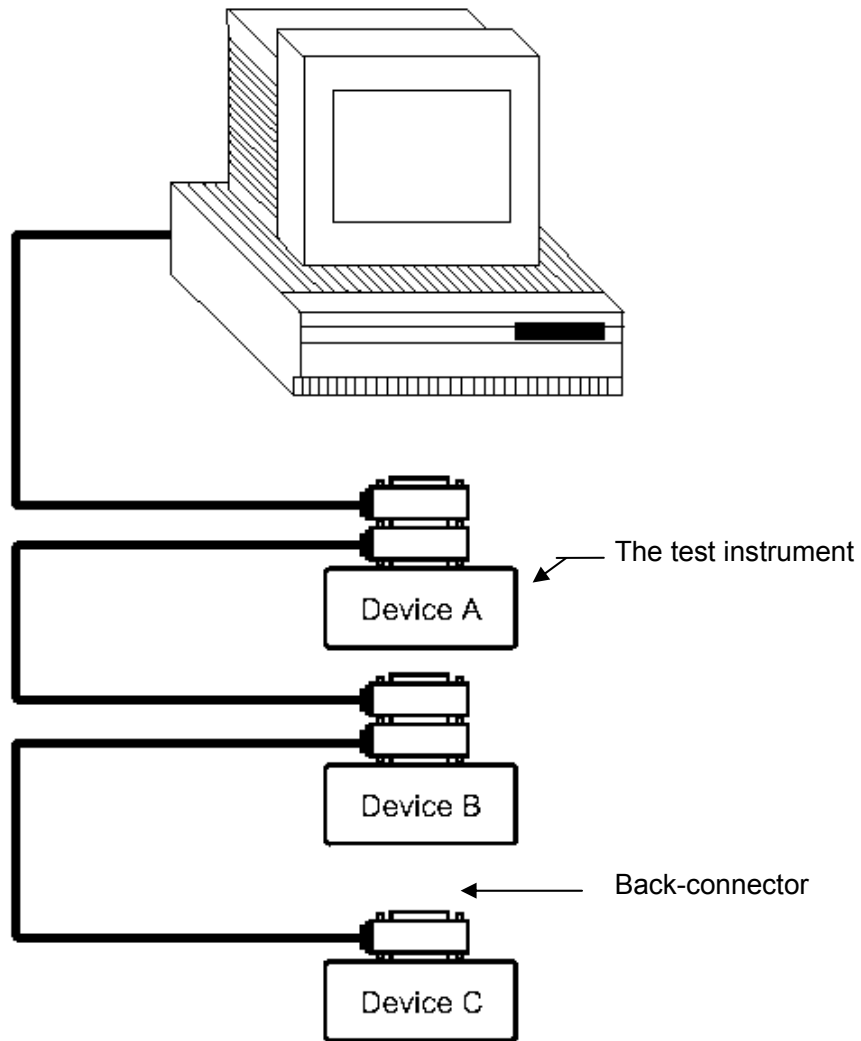

Figure7-3 the two- back-connector superposition

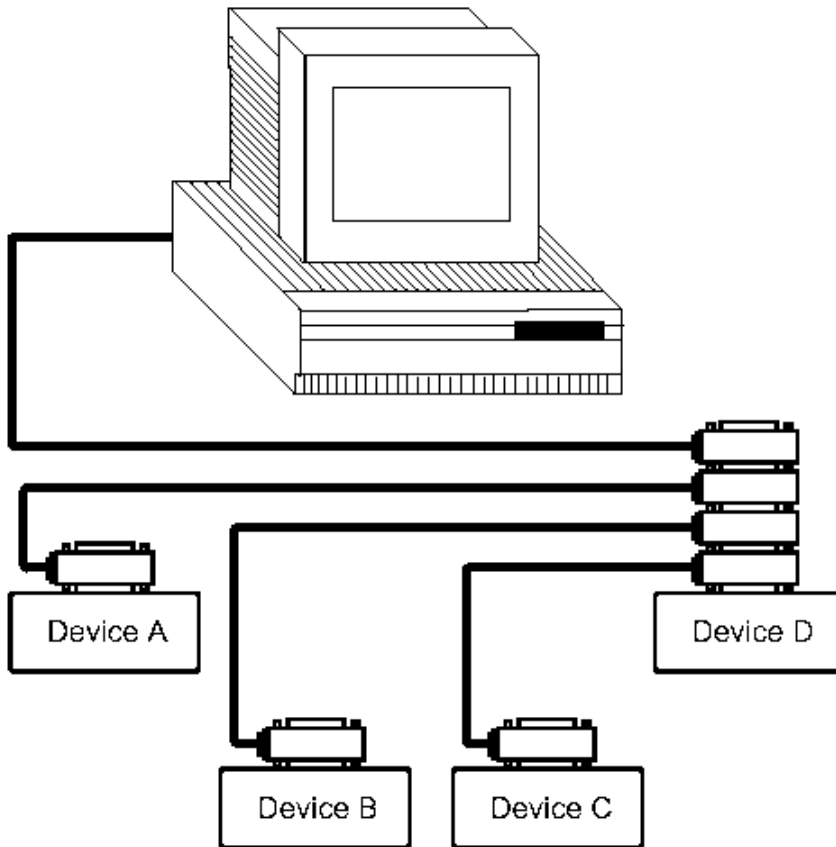

Figure7-4 the four- back-contractor superposition

7.2.1 GPIB interface function

GPIB interface provides various function, the instrument can send and receive the data and the command by the GPIB interface and the corresponding bus, which is shown in table 7-2.

Table 7-2 the GPIB function

| code | Interface function | description |
|------|--------------------------------|--------------------------------|
| SH1 | Data source communication | Three-line communication |
| AH1 | Data destination communication | Three-line communication |
| T5 | Speaking | Send instrument information |
| L4 | Listening | Receive instrument information |
| SR1 | Service request | Request the service |
| RL1 | Remote/local change | Remote/local change |
| DC1 | Reset the instrument | Send "clear signal" |
| DT1 | Instrument trigger | Send trigger signal |
| C0 | control | Send control information |

7.2.2 GPIB address

The range of the GPIB address on TH2819A is from 1 to 31. The setting for GPIB can refer to the bus address field on the SYSTEM SETUP page with the SYSTEM menu key being pressed.

7.2.3 GPIB bus function

The GPIB bus function is completed by the following commands:

- ABORT I/O (IFC): stop the bus working. Don't receive the instrument information, and reset the interface to the idle state.
- CLEAR LOCKOUT/SET LOCAL: control the instrument. The instrument can work at a remote place.
- DEVICE CLEAR (SDC or DCL): clear the selected instruments or all the instruments.
- LOCAL (GTL): return the local control.
- LOCAL LOCKOUT (LLO): lock the local command. When the remote instrument receives this command, the local command will be locked.
- REMOTE: set the instrument to remote mode.
- SPOLL: configure the bus state.
- SERVICE REQUEST: request the control signal.
- TRIGGER (GET): trigger the bus.

7.2.4 SCPI

SCPI is new universal commands based on IEEE488.2-1987. (SCPI is equivalent to TMSL that is Test and Measurement System Language used by HP Company in America.)

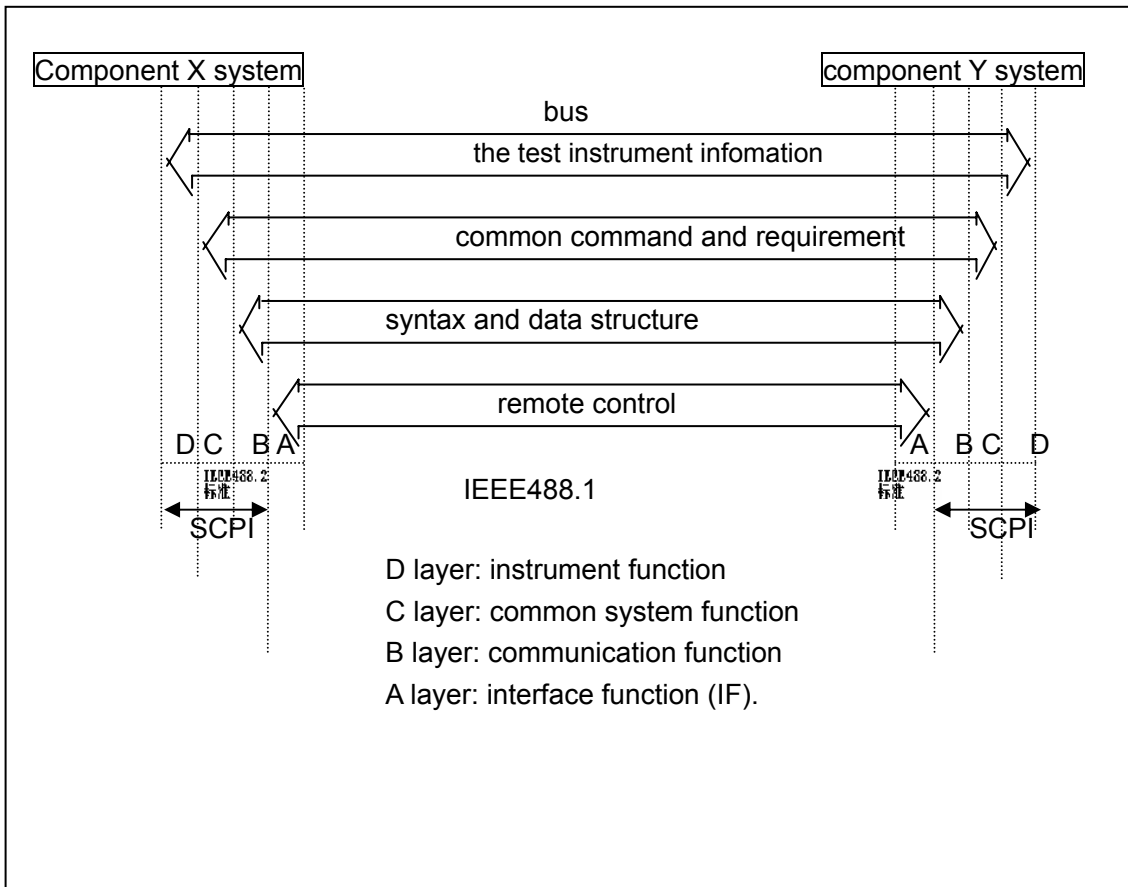

Figure 7-5 the function layers

Chapter 8 TH2819A commands

This chapter describes the commands specific for TH2819A.

The signs in this manual are as follows:

NR1: integer, e.g.: 123

NR2: fix-point number, e.g.:12.3

NR3: floating-point number, e.g.:12.3E+5

NL: carriage key, ASCII code: 10

END: EOI signal in IEEE-488

8.1 Subsystem commands for TH2819A

- DISPlay ●ORESister ●TRIGger ●CORRection
- FREQuency●BIAS ●INITiate ●COMParator
- VOLTage ●FUNCTion ●FETCh? ●Mass MEMory
- CURRent ●LIST ●ABORT ●TRAN
- AMPLitude ●APERture ●STATus ●FRES

8.1.1 DISPlay subsystem command set

DISPLAY subsystem command set is used to set the display page.

Command hierarchical chart:

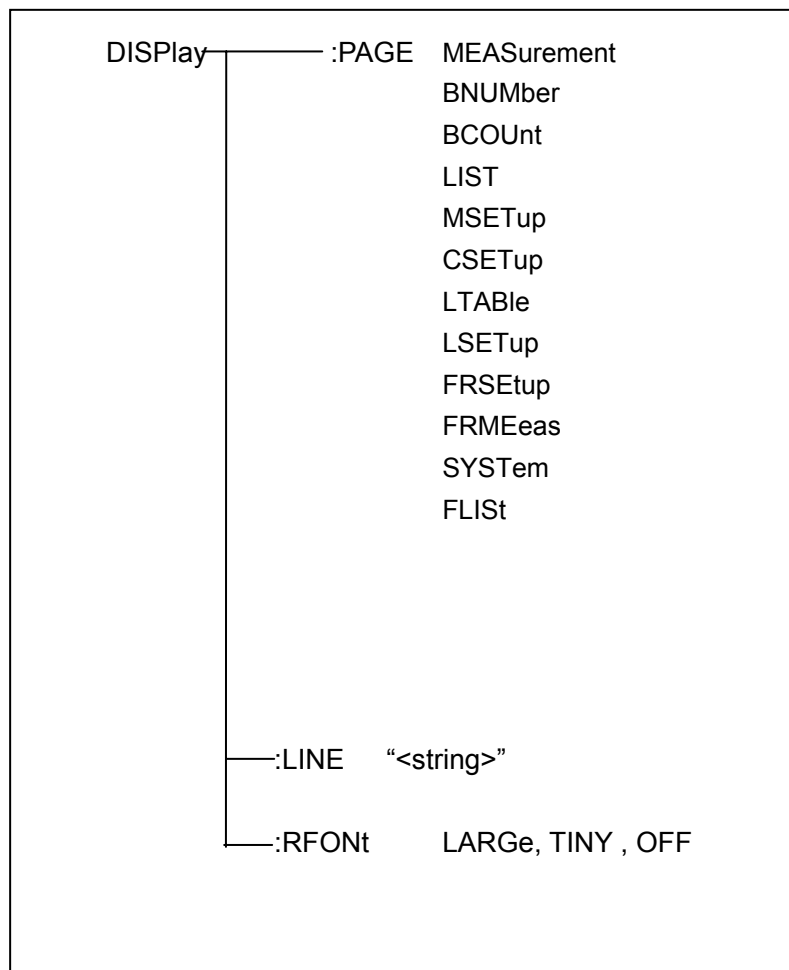

:PAGE is used to set the display page. Char '?' can be used to query the current page.

Command syntax: DISPLAY:PAGE <page name>

The following value can be selected for <page name>:

MEASurement: set the page to LCR Measurement display.
 BNUMber: set the page to BIN Number display.
 BCOUnt: set the page to BIN Count.
 LIST: set the page to List Sweep.
 MSETup: set the page to Measurement setup.
 CSETup: set the page to Correction.
 LTABLE: set the page to Limit Table
 LSETup: set the page to List Setup
 SYSTem: set the page to System Setup
 FLISt: set the page to File List.

E.g.: WrtCmd("ISP:PAGE MEAS"); set the page to LCR Measurement display.

Query syntax: DISPLAY:PAGE?

return: <page name><NL^END>

The following value can be selected for <page name>:

<LCR MEAS DISP>: the current page is LCR Measurement display
 <BIN No. DISP>: the current page is BIN Number display
 <BIN COUNT DISP>: the current page is BIN Count
 <LIST SWEEP DISP>: the current page is List Sweep
 <MEAS SETUP>: the current page is Measurement setup
 <CORRECTION>: the current page is Correction
 <LIMIT TABLE SETUP>: the current page is Limit Table
 <LIST SWEEP SETUP>: the current page is List Setup
 <SYSTEM SETUP>: the current page is System Setup
 <FILE LIST>: the current page is File List

:LINE is used to set the measurement theme. The maximum length of the theme string is 20. Char '?' can be used to query the current measurement theme. The theme string will be displayed in the file list page, and saved as the file name.

Command syntax: DISPLAY:LINE"<string>"

<string> is the ASCII string (the maximum length is 20).

e.g.: WrtCmd("DISP:LINE "Resistor meas");

query syntax: DISPLAY:LINE?

return: <string><NL^END>

:ResultFont is used to set the font of the measurement result. Char '?' can be used to query the current font of the measurement result.

Command syntax: DISPlay:RFONt

The following value can be selected for :

LARGE:display the measurement result with the large size, the hold time is 12 ms.

TINY:display the measurement result with the small size, the hold time is 5 ms.

OFF:don't display the measurement result, but the result can be read from the bus.

Query syntax: DISPlay:RFONt?

return: <NL^END>

the following value can be selected for :

LARGE

TINY

OFF

8.1.2 FREQuency subsystem command set

FREQuency subsystem command set is used to set the test frequency. Char '?' can be used to query the test frequency.

Command syntax:

FREQuency { <value>
MIN
MAX

<value>: NR1,NR2 or NR3 format with Hz,kHz or MHz as the postfix

MIN: set the test frequency to 20Hz

MAX:set the test frequency to 200kHz

e.g.: WrtCmd("FREQ 1KHZ"); set the test frequency to 1000Hz.

Query syntax: FREQuency?

return: <NR3><NL^END>

8.1.3 VOLTage subsystem command set

VOLTage subsystem command set is used to set the voltage level of the measurement instrument. Char '?' can be used to query the current level of the test voltage.

command syntax:
VOLTage { <value>
MIN
MAX

<value>: NR1,NR2 or NR3 format with V as the postfix.

MIN : set the level to 5mV

MAX: set the level to 2V

e.g.: WrtCmd("VOLT 1V"); set the level to 1V

query syntax: VOLTage?

return: <NR3><NL^END>

8.1.4 CURRent subsystem command set

Current subsystem command set is used to set the current level. Char '?' can be used to query the current level of the test instrument.

command syntax:

| | | |
|---------|---|---------|
| CURRent | { | <value> |
| | | MIN |
| | | MAX |

<value>: NR1, NR2 or NR3 format with mA as the postfix.

MIN: set the level to 50 μ A

MAX: set the level to 20mA

e.g.: WrtCmd("CURR 10MA"); set the level to 10mA.

query syntax: CURRent ?

return: <NR3><NL^END>

8.1.5 AMPLitude subsystem command set

AMPLitude subsystem is used to set the Auto Level control(ALC). Char '?' can be used to query the state of the ALC.

Command syntax:

| | | |
|---------------|---|-----|
| AMPLitude:ALC | { | ON |
| | | OFF |
| | | 1 |
| | | 0 |

char '1'(49) is equivalent to ON

char '0'(48) is equivalent to OFF.

e.g.: WrtCmd("AMPL:ALC 0"); set the ALC close

query syntax: AMPLitude:ALC?

return: <NR1><NL^END>

8.1.6 Output RESister subsystem command set

Output RESister subsystem command set is used to set the output internal resistance mode. Char '?' can be used to query the output internal resistance state.

command syntax:

```

    ORESister { 30
               } 100
    
```

e.g.: WrtCmd("ORES 30");set the output internal resistance to 30 OHM

query syntax: ORESister?
 return: <NR1><NL^END>

8.1.7 OUTPut subsystem command set

OUTPut subsystem command set is used to set the DC 100mA/10V bias source, and the DC isolation.

Command hierarchical chart:

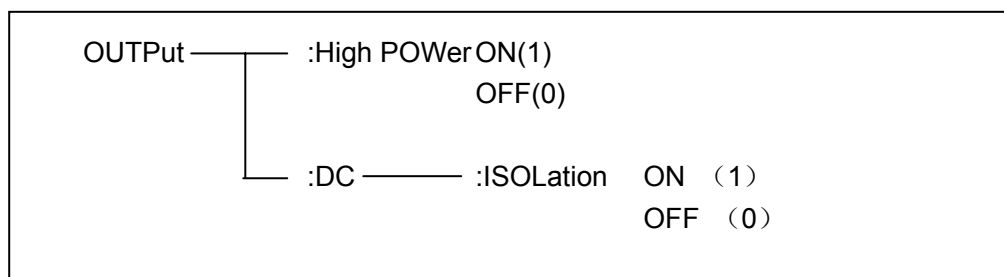

:HPOWER is used to set the DC 100mA/10V bias ON/OFF. Char '?' can be used to query the state of the bias source.

You must ensure that you have bought the DC 100mA/10V bias source (optional) from Tonghui company before you perform this command.

Command syntax:

```

    OUTPut:HPOWER { ON
                   } OFF
                   } 1
                   } 0
    
```

char '1'(49) is equivalent to ON
 char '0'(48) is equivalent to OFF.

query syntax: OUTPut:HPOWER?

return: <INT> <NL^END> or <OPT1><NL^END>, OPT1 shows that the DC

100mA/10V bias source is used, or not used.

:DC:ISOLation is used to set DC isolation ON/OFF of the DC 100mA/10V bias source. Char '?' can be used to query the DC isolation ON/OFF. You must ensure that you have bought the DC 100mA/10V bias source (optional) from Tonghui company before you perform this command.

command syntax:

OUTPut:DC:ISOLation { ON
OFF
1
0

char '1'(49) is equivalent to ON
char '0'(48) is equivalent to OFF.

query syntax: OUTPut:DC:ISOLation?

return: <NR1> <NL^END>.

8.1.8 BIAS subsystem command set

BIAS subsystem command set is used to set the internal bias voltage.

Command hierarchical chart:

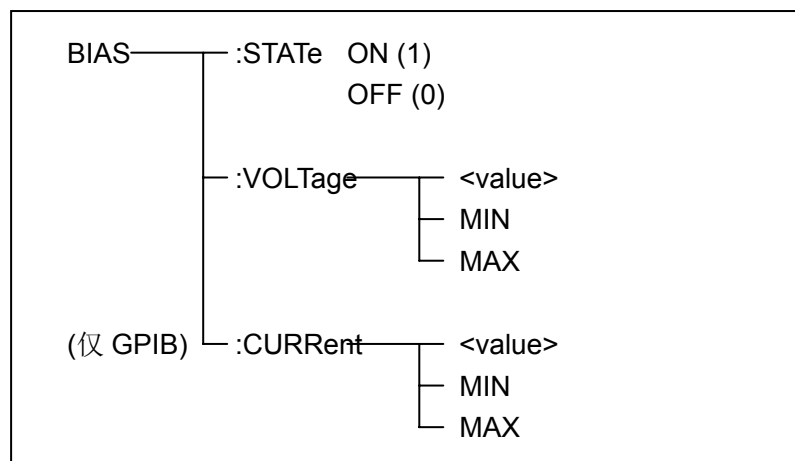

:STATE is used to set the bias ON/OFF. Char '?' can be used to query the state of the bias.

Command syntax:

BIAS:STATE { ON
OFF
1

0

char '1' (49) is equivalent to ON

char '0' (48) is equivalent to OFF.

e.g.: WrtCmd("BIAS:STATe 0"); set the DC bias close.

query syntax: BIAS:STATe?

return: <NR1><NL^END>

:VOLTage is used to set the bias voltage. Char '?' is used to query the current bias voltage.

Command syntax:

$$\text{BIAS:VOLTage} \left\{ \begin{array}{l} \text{<value>} \\ \text{MIN} \\ \text{MAX} \end{array} \right.$$

<value>: NR1,NR2 or NR3 format

MIN : set the bias voltage to 0V

MAX: set the bias voltage to 2V

e.g.: WrtCmd("BIAS:VOLT MIN");set the bias voltage to 0V

query syntax: BIAS:VOLTage?

return: <NR3><NL^END>

:CURRent (only for GPIB) is used to the external bias current. Char '?' is used to query the bias current. Because the external bias current is controlled by serial interface, this command is supported only by GPIB.

command syntax:

$$\text{BIAS: CURRent} \left\{ \begin{array}{l} \text{<value>} \\ \text{MIN} \\ \text{MAX} \end{array} \right.$$

<value>: NR1,NR2 or NR3 format

MIN : to set the bias current to 0A

MAX :to set the bias current to 10A

e.g.: WrtCmd("BIAS:CURR MIN"); set the bias current to 0A

query syntax: BIAS: CURRent?

return: <NR3><NL^END>

8.1.9 FUNCTION subsystem command set

FUNCTION subsystem command set is used to set the measurement function, range

function, monitor for current and voltage, deviation display mode and standard value setting.

Command hierarchical chart:

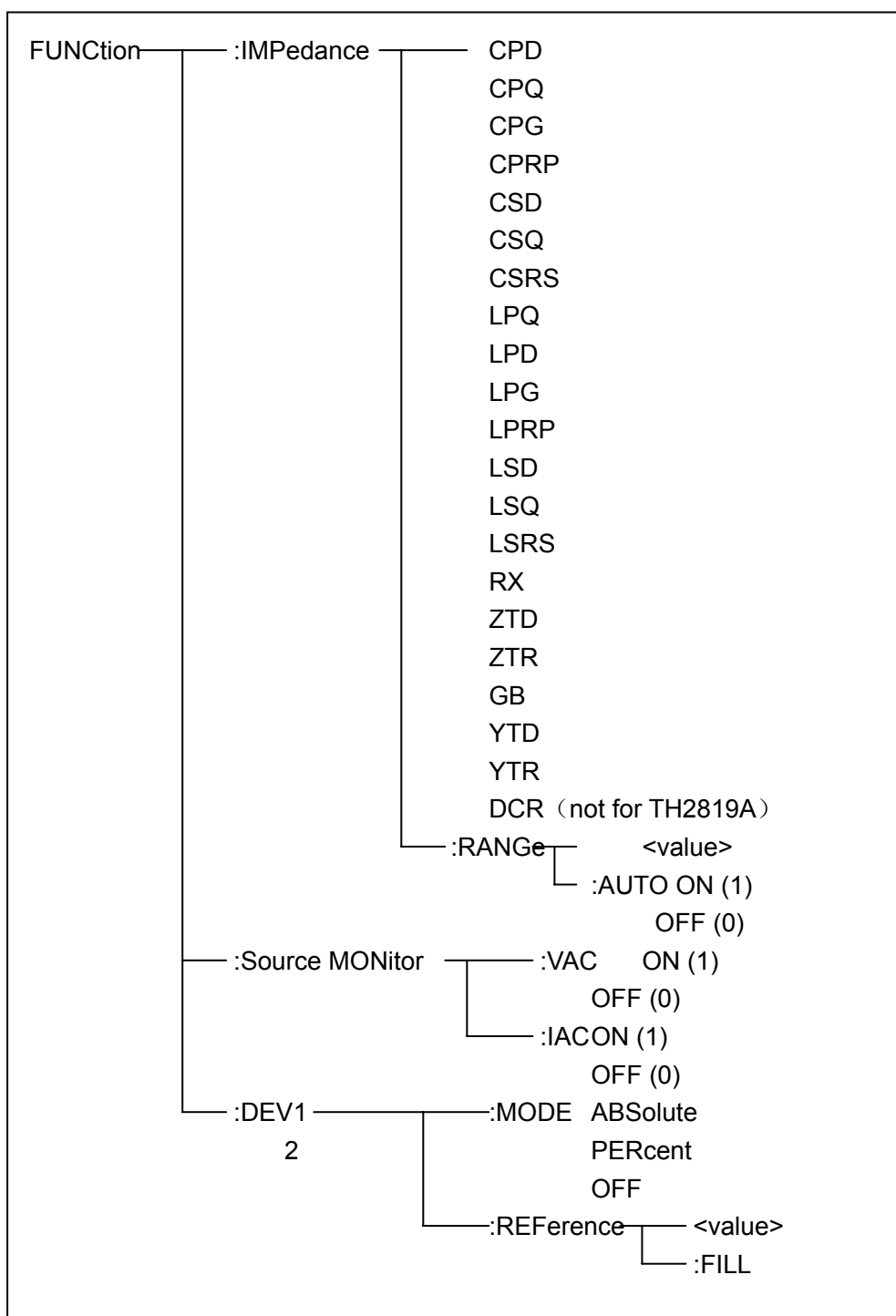

:IMPedance is used to set the function. Char '?' is used to query the current function parameter.

command syntax: FUNction:IMPedance <function>

the following value can be selected for <function>

- CPD: set the function to Cp-D
- CPQ: set the function to Cp-Q
- CPG: set the function to Cp-G
- LPRP: set the function to Lp-Rp
- LSD: set the function to Ls-D
- LSQ: set the function to Ls-Q

| | |
|---------------------------------|---------------------------------|
| CPRP: set the function to Cp-Rp | LSRS: set the function to Ls-Rs |
| CSD: set the function to Cs-D | RX: set the function to R-X |
| CSQ: set the function to Cs-Q | ZTD: set the function to Z-θ° |
| CSRS: set the function to Cs-Rs | ZTR: set the function to Z-θr |
| LPQ: set the function to Lp-Q | GB: set the function to G-B |
| LPD: set the function to Lp-D | YTD: set the function to Y-θ° |
| LPG: set the function to Lp-G | YTR: set the function to Y-θr |

e.g.: WrtCmd("FUNC:IMP RX"); ; set the function to R-X

query syntax: FUNCtion:IMPedance?

return: <function><NL^END>

:IMPedance:RANGe is used to set the range. Char '?' is used to query the current range

command syntax: FUNCtion:IMPedance:RANGe <value>

<value> can be the resistance of the DUT, or the NR1,NR2,NR3 format with OHM,KOHM as the postfix.

e.g.: WrtCmd("FUNC:IMP:RANG 1KOHM"); set the range to 1kOHM.

Query syntax: FUNCtion:IMPedance:RANGe?

return: <value><NL^END>

the following value can be selected for <value>:

| | | |
|-------|-------|--------|
| 10 | 30 | 100 |
| 300 | 1000 | 3000 |
| 10000 | 30000 | 100000 |

:IMPedance:RANGe:AUTO is used to select AUTO range. Char '?' can be used to query the current range.

command syntax:

FUNCtion:IMPedance:RANGe:AUTO { ON (1)
OFF (0)

char '1'(49) is equivalent to ON

char '0'(48) is equivalent to OFF.

e.g.: WrtCmd("FUNC:IMP:RANG:AUTO ON"); set the range to AUTO

query syntax: FUNCtion:IMPedance:RANGe:AUTO?

return: <NR1><NL^END>

:Source MONitor:VAC is used to set the monitor for voltage. Char '?' can be used to query the state of the voltage monitor.

Command syntax:

FUNCtion:SMONitor:VAC { ON (1)
OFF (0)

char '1'(49) is equivalent to ON
 char '0'(48) is equivalent to OFF.

e.g.: WrtCmd("FUNC:SMON:VAC ON"); set the voltage monitor ON.

query syntax: FUNCtion:SMONitor:VAC?
 return: <NR1><NL^END>

:Source MONitor:IAC is used to set the current monitor. Char '?' can be used to query the state of the current monitor.

command syntax:

FUNCtion:SMONitor:IAC { ON (1)
 OFF (0)

char '1'(49) is equivalent to ON
 char '0'(48) is equivalent to OFF.

e.g.: WrtCmd("FUNC:SMON:IAC ON"); set the current monitor ON

query syntax: FUNCtion:SMONitor:IAC?
 return: <NR1><NL^END>

: DEV<n>:MODE is used to set the deviation measurement mode. Char '?' is used to query the state of the deviation measurement mode.

command syntax:

FUNCtion:DEV<n>:MODE { ABSolute
 PERCent
 OFF

ABSolute: absolute deviation display

PERCent: percent deviation display

OFF: the direct display for the test value

<n>:

char '1'(49): set the deviation mode of the main parameters

char '2'(50): set the deviation mode of the secondary parameters

e.g.: WrtCmd("FUNC:DEV1:MODE ABS");

query syntax: FUNCtion:DEV<n>:MODE?

return: ABS } <NL^END>
 PERC }
 OFF }

:DEV<n>:REFerence is used to set the standard deviation. Char '?' is used to query the current standard deviation.

command syntax: FUNCtion:DEV<n>:REFerence<value>

<value>:NR1,NR2 or NR3 format

<n>:

char '1'(49):set the standard deviation of the main parameters

char '2'(50):set the standard deviation of the secondary parameters

e.g.: WrtCmd("FUNC:DEV1:REF 10");

query syntax: FUNCtion:DEV<n>:REFerence?

return: <NR3><NL^END>

:DEV<n>:REFerence:FILL is used to set the standard deviation, which controls the instrument only for one time. And copy the main and the secondary parameters as the standard deviation.

command syntax: FUNCtion:DEV<n>:REFerence:FILL

<n>: char '1'(49) or char '2'(50) can be used to set the standard deviation for the main parameters and the secondary parameters.

e.g.: WrtCmd("FUNC:DEV1:REF:FILL");

8.1.10 LIST subsystem command set

LIST subsystem command set is used to set the List Sweep, the sweep point, the sweep mode and limit comparison.

Command hierarchical chart:

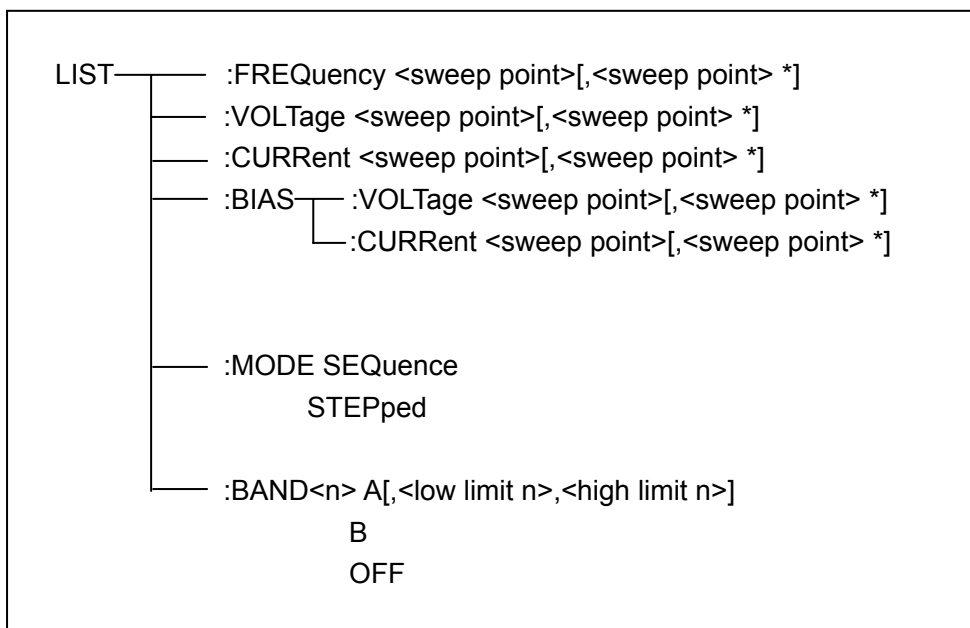

:FREQUENCY is used to clear the previous sweep point and set the frequency of the sweep point.

:BIAS:VOLTage is used to clear the DC bias voltage in the list sweep points before and set the the DC bias voltage.

command syntax: LIST:BIAS:VOLTage <value>[,<value> *]

note: " *" shows that the sweep points are 10 points at most.

<value> :NR1, NR2 or NR3 format

e.g.: WrtCmd("LIST:BIAS:VOLT 1.5V") ;set the DC bias voltage of the sweep point 1 to 1.5V.

query syntax: LIST:BIAS:VOLTage?

return: <NR3>[,<NR3> *]<NL^END>

note:the DC bias voltage must be 0 V, 1.5 V and 2 V, or the return value will be "error"..

:BIAS:CURRent is used to clear the DC bias current in the list sweep points before and set the DC bias current.

Command syntax: LIST:BIAS:CURRent <value>[,<value> *]

note: " *" shows that the sweep points are 10 points at most.

<value>:NR1, NR2 or NR3 format

e.g.: WrtCmd("LIST:BIAS:CURR 100MA") ;set the DC current of the sweep point 1 to100mA

WrtCmd("LIST:BIAS:CURR 1E-2,2E-2,3E-2,4E-2") ;set the DC current of the sweep point 1,2,3 and 4 to 10mA, 20mA, 30mA and 40mA

quety syntax: LIST:BIAS:CURRent?

return: <NR3>[,<NR3> *]<NL^END>

note: because TH2819A and TH2819 have no internal DC bias current source, the instrument must be used with the external DC bias source(TH1773, must be bought.) together.

:MODE is used to set the list sweep mode.

command syntax:

| | | | |
|-----------|---|----------|---|
| LIST:MODE | { | SEQuence | } |
| | | STEPped | |

SEQuenc: sequence mode

STEPped: stepped mode

e.g.: WrtCmd("LIST:MODE SEQ")

query syntax: LIST: MODE?

return:

| | | | |
|---|------|---|----------|
| { | SEQ | } | <NL^END> |
| | STEP | | |

:BAND<n> is used to set the limit data in the list sweep table.

command syntax: LIST:BAND<n><parameter>[,<low limit n>,<high limit n>]

<n> 1 to 10 (NR1 format): sweep point in the line n

- <parameter>: A compare the main parameter of the measurement result with the high limit and the low limit.
 B compare the secondary parameter of the measurement result with the high limit and the low limit.

OFF: don't do the comparison.

<low limit n>: NR1, NR2 or NR3 format, the low limit data in the line n

<high limit n>: NR1, NR2 or NR3 format, the high limit data in the line n.

e.g.: WrtCmd("LIST:BAND1 A,10,20")

WrtCmd("LIST:BAND3 OFF")

query syntax: LIST:BAND<n>?

return: <parameter>,<low limit n>,<high limit n>

8.1.11 APERTure subsystem command set

APERtures subsystem command set is used to set the measurement speed, the average times. Char '?' can be used to query the current speed, the average times.

command syntax:

APERture { FAST
 MEDium } [, <value>]
 SLOW }

FAST: fast, 30times/s

MEDium: medium, 10 times/s

SLOW: slow, 2 times/s

<value> 1 to 128(NR1 format), the average times.

e.g.: WrtCmd("APER MED,55");

query syntax: APERTure?

return: { FAST
 MED } ,<NR1><NL^END>
 SLOW }

8.1.12 TRIGger subsystem command set

TRIGger subsystem command set is used to set the trigger source, the delay time after the trigger and trigger instrument test.

Command hierarchical chart:

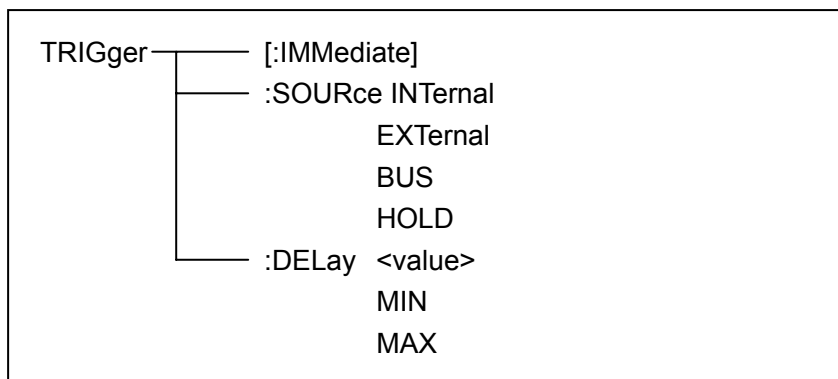

:IMMEDIATE is used to trigger the instrument only one time.

command syntax: TRIGGER[:IMMEDIATE]

e.g.: WrtCmd("TRIG");

:SOURCE is used to set the trigger source mode. Char '?' can be used to query the current mode of the trigger source

command syntax:

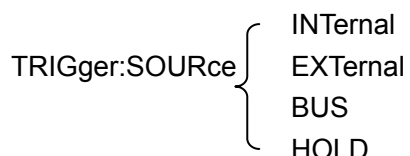

INTERNAL :triggered by the instrument itself automatically. It is the default setting.

EXTERNAL:triggered by the HANDLER interface.

BUS:triggered by RS232 or GPIB interface.

HOLD: triggered by the **TRIGGER** key in the front panel.

e.g.: WrtCmd("TRIG:SOUR BUS");

query syntax: TRIGGER:SOURCE?

return:

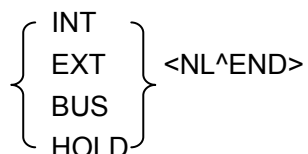

:DELAY is used to set the delay time after the instrument is triggered. Char '?' can be used to query the delay parameter.

command syntax:



<value>: NR1,NR2 or NR3 format, 0 to 60 s with 1ms as the resolution.

MIN : set the delay time to 0 s.

MAX:set the delay time to 60 s.

e.g.: WrtCmd("TRIG:DEL 5S"); set the delay time to 5 s.

query syntax: TRIGger:DELAy?

return: <NR3><NL^END>

8.1.13 FETCh? subsystem command set

FETCh? subsystem command set is used to transmit a test result.

Command hierarchical chart:

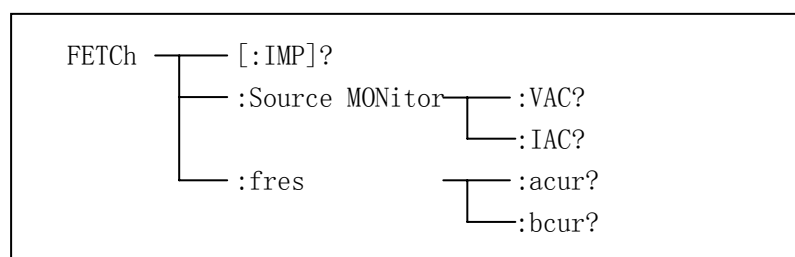

[:IMP]? is used to notify the TH2819A to transmit the test result to the buffer.

query syntax: FETCh[:IMP]?

e.g.: WrtCmd("TRIG:SOUR BUS");

WrtCmd("TRIG");

WrtCmd("FETC?");

TH2819A transmits the result with ASCII, the more details are below:

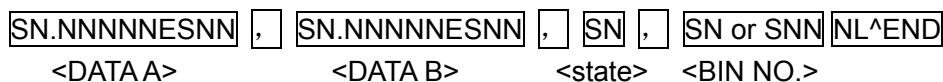

Figure 8-1 the ASCII format 1

<DATA A>,<DATA B> format: <DATA A> (the main parameter), <DATA B> (the secondary parameter) are ASCII code with 12 bits:

SN.NNNNNESNN

(S: +/-, N: 0 to 9, E: Exponent Sign)

<state>format: when the following value is selected, <state> will display the test state.

| state | description |
|-------|---|
| -1 | no data in buffer |
| 0 | normal test data |
| +1 | analog bridge is imbalance |
| +2 | ADC can't work. |
| +3 | signal I source overload |
| +4 | the constant voltage can't be adjusted. |

The data format for <state> is ASCII code with 2 bits:

SN (S: +/-, N: 0 to 4)

Note: when the <state> is -1,1 or 2, the test data is 9.9E37. when the <state > is 0,3 or 4, the test data will out of range.

<BIN>format: the data displays the sorted result:

| data | selected result |
|------|-------------------|
| 0 | Over the standard |
| +1 | BIN 1 |
| +2 | BIN 2 |
| +3 | BIN 3 |
| +4 | BIN 4 |
| +5 | BIN 5 |
| +6 | BIN 6 |
| +7 | BIN 7 |
| +8 | BIN 8 |
| +9 | BIN 9 |
| +10 | Auxiliary BIN |

Only when the comparison function is ON, <BIN>data will be displayed.

<BIN> data is the ASCII code with 2 or 3 bits:

SN or SNN (S: +/-, N: 0 to 9)

The ASCII data output format in the list sweep page is below:

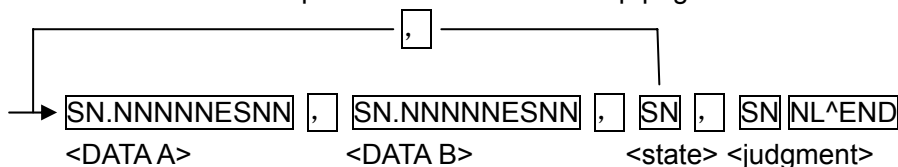

Figure 8-2 ASCII format 2(for list sweep)

<DATA A>,<DATA B>,<state> are the same to the ones above, < judgment > is described as follows: <input/output>format: display the comparison function for list sweep.

| data | result |
|------|--------|
| -1 | lower |
| 0 | good |
| 1 | higher |

When the comparison function for list sweep is OFF, <input/output> the output is 0.

<input/output>data format is ASCII code with 2 bits:

SN (S: +/-, N: 0 to 1)

On the test display page for the single transformer, the ASCII format is as follows:

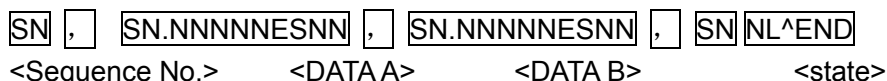

Figure 8-3 ASCII format 3(for single transformer)

<sequence NO.> is shown in table 8-1:

Table 8-1 the sequence NO. and the description

| Sequence NO. | description |
|--------------|-------------|
| 1 | TURN |
| 2 | Lx |
| 3 | LK |
| 4 | DCR |

<DATA A> is the same to the one above.

<DATA B>(the secondary parameter) has two formats:

When the test parameter is TURN, <DATA B> is the phase. The format is: +(same phase), -(reversed phase).

When the test parameter is Lx, <DATA B> is quality factor, the description is the same to <DATA A>.

At the same time, when the sequence number is greater than 3, there is no secondary parameter, and the state is displayed directly.

SN: +/-; N:0/1, described as the table below:

| state | description |
|-------|-------------|
| -1 | lower |
| 0 | good |
| 1 | higher |

8.1.14 CORRection subsystem command set

CORRection subsystem command set is used to set the correction function(short, open or load correction).

Command hierarchical chart:

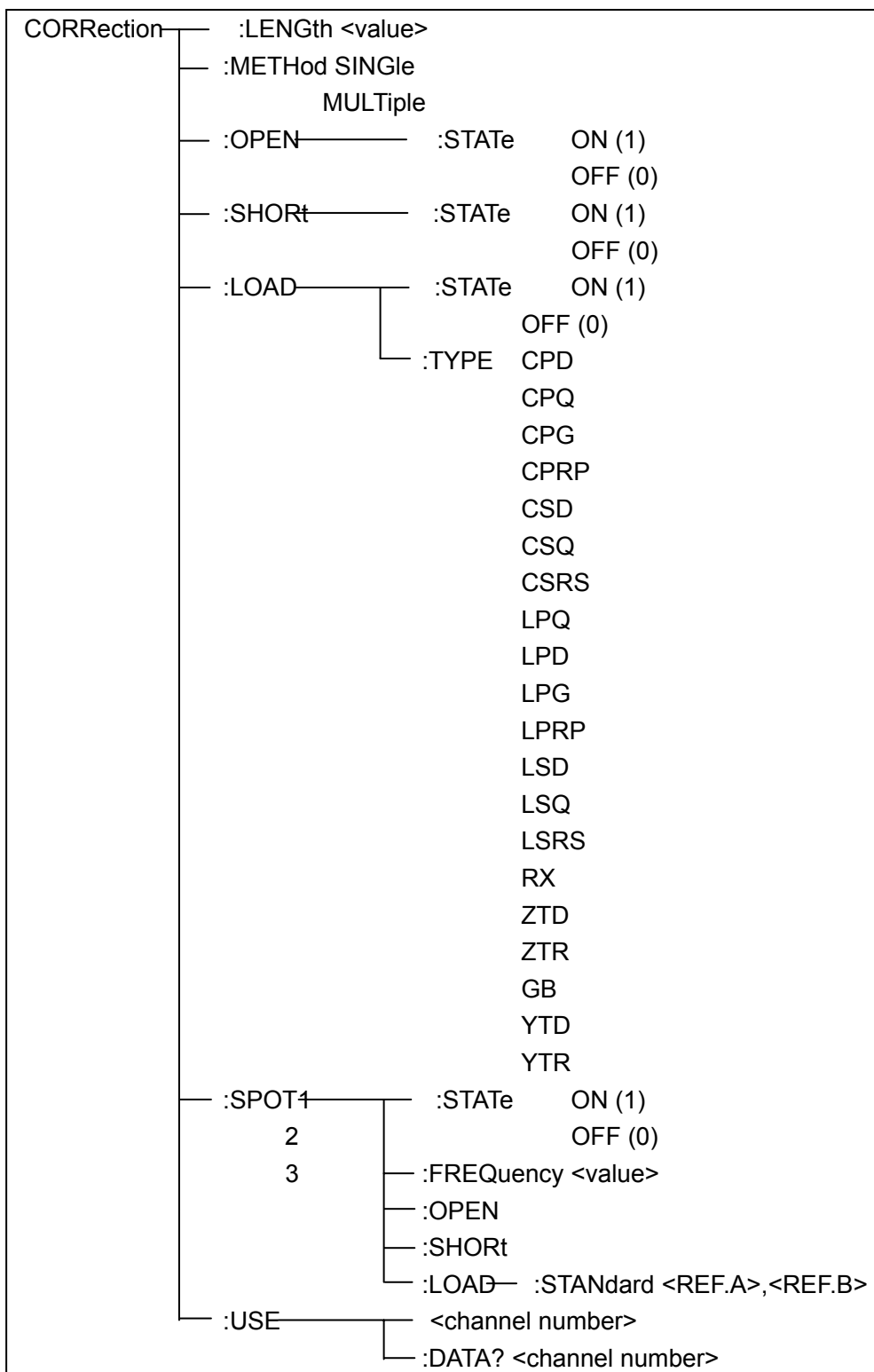

:LENGth is used to set the length of the correction cable. Char '?' is used to query the current length of the cable.

command syntax: CORRection:LENGth <value>

<value>:0, 1 or 2 with the unit m as the postfix.

e.g.: WrtCmd("CORR: LENG 1m") :set the cable length to 1m.

query syntax: CORRection:LENGth?

return: <NR1><NL^END>

:METHod is used to set the correction mode. Char '?' can be used to query the correction mode. command syntax: CORRection:METHod

$$\left\{ \begin{array}{l} \text{MULTi} \\ \text{SINGle} \end{array} \right\}$$

SINGle:set or return the single channel mode.

MULTi: set or return the multi-channel mode.

e.g.: WrtCmd("CORR:METH MULT") ;set the instrument to multi-channel mode

query syntax: CORRection:METHod?

return: $\left\{ \begin{array}{l} \text{SINGle} \\ \text{MULTi} \end{array} \right\} <NL^END>$

:OPEN is used to perform the correction data of 41 preset test points.

command syntax: CORRection:OPEN

e.g.: WrtCmd("CORR:OPEN")

:OPEN:STATe is used to set the open correction function. Char '?' is used to query the state of the open correction.

command syntax:

$$\text{CORRection:OPEN:STATe} \left\{ \begin{array}{l} \text{ON} \\ \text{OFF} \\ 1 \\ 0 \end{array} \right\}$$

char '1'(49) :enable the open correction, which is equivalent to ON

char '0'(48): forbid the open correction, which is equivalent to OFF.

e.g.: WrtCmd("CORR:OPEN:STAT ON")

query syntax: CORRection:OPEN:STATe?

return: <NR1><NL^END>

:SHORT is used to perform the short correction data of 41 preset test points.

command syntax: CORRection:SHORT

e.g.: WrtCmd("CORR:SHOR")

:SHORT:STATe is used to set the short correction function. Char '?' is used to query the state of the short correction.

Command syntax:

$$\text{CORRection:SHORT:STATe} \left\{ \begin{array}{l} \text{ON} \\ \text{OFF} \\ 1 \\ 0 \end{array} \right\}$$

char '1'(49):enable the short correction, which is equivalent to ON.

char '0'(48):forbid the short correction, which is equivalent to OFF.

e.g.: WrtCmd("CORR:SHOR:STAT ON")

query syntax: CORRection:SHORT:STATe?

return: <NR1><NL^END>

:LOAD:STATE is used to set the load correction function. Char '?' is used to query the state of the load correction.

command syntax:

CORRection:LOAD:STATe $\left. \begin{array}{l} \text{ON} \\ \text{OFF} \\ 1 \\ 0 \end{array} \right\}$

char '1'(49):enable the load correction, which is equivalent to ON.

char '0'(48):forbid the load correction, which is equivalent to OFF.

e.g.: WrtCmd("CORR: LOAD: STAT ON")

query syntax: CORRection:LOAD:STATe?

return: <NR1><NL^END>

:LOAD:TYPE is used to set the combination parameter function for the load correction.

Char '?' is used to query the type of the combination parameter.

Fuction:

CPD: set the function to Cp-D

LPRP: set the function to Lp-Rp

CPQ: set the function to Cp-Q

LSD: set the function to Ls-D

CPG: set the function to Cp-G

LSQ: set the function to Ls-Q

CPRP: set the function to Cp-Rp

LSRS: set the function to Ls-Rs

CSD: set the function to Cs-D

RX: set the function to R-X

CSQ: set the function to Cs-Q

ZTD: set the function to Z-θ°

CSRS: set the function to Cs-Rs

ZTR: set the function to Z-θr

LPQ: set the function to Lp-Q

GB: set the function to G-B

LPD: set the function to Lp-D

YTD: set the function to Y-θ°

LPG: set the function to Lp-G

YTR: set the function to Y-θr

e.g.: WrtCmd("CORR:LOAD:TYPE CPD")

query syntax: CORRection:LOAD:TYPE?

return: <function><NL^END>

:SPOT<n>:STATE is used to set the particular frequency point. Char '?' is used to query the state of the current frequency point(frequency 1, frequency 2 or frequency 3.)

command syntax:

CORRection:SPOT<n>:STATe $\left\{ \begin{array}{l} \text{ON} \\ \text{OFF} \\ 1 \\ 0 \end{array} \right\}$

char '1'(49) is equivalent to ON
 char '0'(48) is equivalent to OFF

<n>:

- 1:frequency point 1
- 2:frequency point 2
- 3:frequency point 3

e.g.: WrtCmd("CORR:SPOT1:STAT ON")

query syntax: CORRection:SPOT<n>:STATe?

return: <NR1><NL^END>

:SPOT<n>:FREQuency is used to set the frequency of the particular frequency point 1, 2 and 3. char '?' is used to query the current frequency of the frequency point.

command syntax: CORRection:SPOT<n>:FREQuency <value>

<value> : NR1,NR2 or NR3 format with HZ, KHZ and MHZ as the shortfix.

<n>:

- 1:frequency point 1
- 2:frequency point 2
- 3:frequency point 3

e.g.: WrtCmd("CORR:SPOT1:FREQ 2KHZ") ;set frequency 1 to 2 kHz

note: the range of <value> must be 20Hz to 200kHz, or the return value will be "error".

query syntax: CORRection:SPOT<n>:FREQuency?

return: <NR3><NL^END>

:SPOT<n>:OPEN is used to perform the open correction for the particular frequency points(point 1,point 2 and point 3).

command syntax: CORRection:SPOT<n>:OPEN

<n>:

- 1:frequency point 1
- 2:frequency point 2
- 3:frequency point 3

e.g.: WrtCmd("CORR:SPOT1:OPEN") ;perform the open correction for frequency point 1.

:SPOT<n>:SHORT is used to perform the short correction for the particular frequency points(point1, point 2 and point 3).

command syntax: CORRection:SPOT<n>:SHORT

<n>:

1:frequency point 1

2:frequency point 2

3:frequency point 3

e.g.: WrtCmd("CORR:SPOT1:SHOR") ;perform the short correction for point 1

:SPOT<n>:LOAD:STANdard is used to perform the load correction for the particular frequency points(point 1, point 2 and point 3) under the standard reference value.

command syntax: CORRection:SPOT<n>:LOAD:STANdard <REF.A>,<REF.B>

<n>:

1:frequency point 1

2:frequency point 2

3:frequency point 3

<REF.A> : NR1, NR2 or NR3 format, is the standard reference value for the main parameter

<REF.B> : NR1, NR2 or NR3 format, is the standard reference value for the secondary parameter

e.g.:WrtCmd("CORR:SPOT1:LAOD:STAN 100.7,0.0002")

query syntax: CORRection:SPOT<n>:LOAD:STANdard?

return: <NR3>,<NR3><NL^END>

:USE is used to set the channel number for multi-channel. Char '?' can be used to query the used channel number.

command syntax: CORRection:USE <channel number>

<channel number>:the channel number from 1 to 127(NR1, NR2 or NR3 format).

e.g.: WrtCmd("CORR:USE 10") ;set the channel number to 10

query syntax: CORRection:USE?

return: <channel number><NL^END>

:USE:DATA? is used to query the test data of the open/short/load correction for the particular frequency point 1,2 or 3.

query syntax: CORRection:USE:DATA? <channel number>

<channel number>:1 to 127 (NR1 format)

return: <open1 A>,<open1 B>,<short1 A>,<short1 B>,<load1 A>,<load1 B>,
<open2 A>,<open2 B>,<short2 A>,<short2 B>,<load2 A>,<load2 B>,

<open3 A>,<open3 B>,<short3 A>,<short3 B>,<load3 A>,<load3 B>,
<open1/2/3 A>:NR3 format, the open correction data of the main parameter for frequency point 1/2/3.

<open1/2/3 B>:NR3 format, the open correction data of the secondary parameter for frequency point 1/2/3.

<short1/2/3 A>:NR3 format, the short correction data of the main parameter for frequency point 1/2/3.

<short1/2/3 B>:NR3 format, the short correction data of the secondary parameter for frequency point 1/2/3.

<load1/2/3 A>:NR3 format, the load correction data of the main parameter for frequency point 1/2/3.

<load1/2/3 B>:NR3 format, the load correction data of the secondary parameter for frequency point 1/2/3.

8.1.15 COMParator subsystem command set

COMParator subsystem command set is used to set the BIN comparator, including setting the compator ON/OFF, setting the limit list.

Command hierarchical chart:

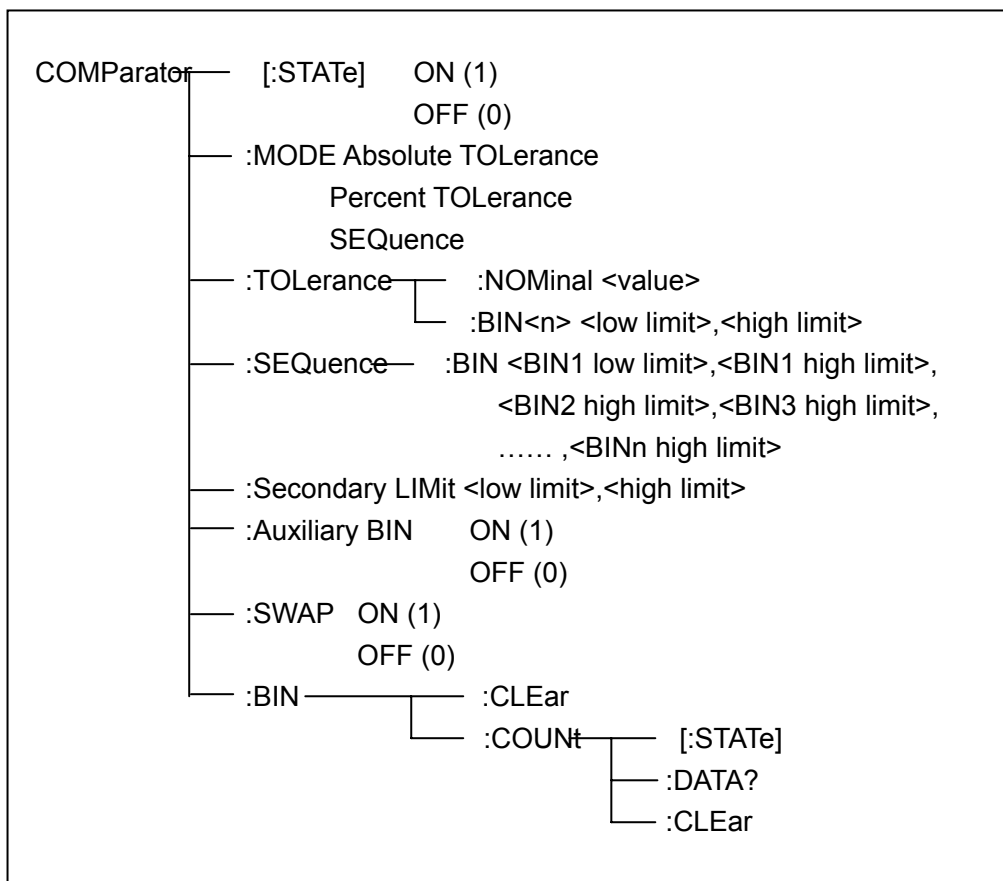

[:STATe] is used to set the comparator ON/OFF,

command syntax:

$$\text{COMPArator[:STATe]} \left\{ \begin{array}{l} \text{ON} \\ \text{OFF} \\ 1 \\ 0 \end{array} \right.$$

char '1'(49) is equivalent to ON
 char '0'(48) is equivalent to OFF

e.g.: WrtCmd("COMP ON")

query syntax: COMPArator[:STATe]?

return: <NR1><NL^END>

:MODE is used to set limit mode for comparator. Char '?' is used to query the limit mode.

command syntax:

$$\text{COMPArator:MODE} \left\{ \begin{array}{l} \text{ATOLerance} \\ \text{PTOLerance} \\ \text{SEQuence} \end{array} \right.$$

ATOLerance:set the absolute error mode
 PTOLerance:set the relative error mode

SEquence:set sequence mode

e.g.: WrtCmd("COMP:MODE ATOL")

query syntax: COMPArator:MODE?

return: $\left\{ \begin{array}{l} \text{ATOL} \\ \text{PTOL} \\ \text{SEQ} \end{array} \right\} \langle \text{NL}^{\wedge} \text{END} \rangle$

:TOLerance:NOMinal is used to set the standard value of the error mode for the comparator(this mode is effective only when the limit mode is error mode.).

command syntax: COMPArator:TOLerance:NOMinal <value>

<value>:the standard value with NR1, NR2 or NR3 format

e.g.: WrtCmd("COMP:TOL:NOM 100E-12")

query syntax: COMPArator:TOLerance:NOMinal?

return: <NR3><NL^END>

:TOLerance:BIN<n> is used to set the low limit and the high limit of every BIN on the comparator error mode(this function is effective only when the limit mode is set to the error mode.)

command syntax: COMPArator:TOLerance:BIN<n><low limit>,<high limit>

<n>:1 to 9 (NR1 format) , BIN number

<low limit>: NR1, NR2 or NR3 format, the low limit

<high limit>: NR1, NR2 or NR3 format, the high limit

Note: the low limit should be less than the high limit, or the error message will be prompted.

e.g. : WrtCmd("COMP:TOL:BIN1 -5,5")

WrtCmd("COMP:TOL:BIN2 -10,10")

query syntax: COMPArator:TOLerance:BIN<n>?

return: <low limit>,<high limit><NL^END>

:SEquence:BIN is used to set the high limit and the low limit of the comparator on the sequence mode(this function is effective only when the limit mode is set to sequence mode.).

command syntax: COMPArator:SEquence:BIN <BIN1 low limit>,<BIN1 high limit>,
<BIN2 high limit>,..., <BINn high limit>

<BIN1 low limit>: NR1, NR2 or NR3 format, the low limit of BIN 1.

<BIN1 high limit>: NR1, NR2 or NR3 format, the high limit of BIN 1.

<BINn high limit>: NR1, NR2 or NR3 format, the high limit of BIN n(the maximum value of n is 9).

Note:the low limit should be less than the high limit

e.g.: WrtCmd("COMP:SEQ:BIN 10,20,30,40,50")

query syntax: COMPArator:SEQuence:BIN?

return: <BIN1 low limit>,<BIN1 high limit>,<BIN2 high limit>,...,
<BINn high limit><NL^END>

:Secondary LIMit is used to set the high limit and the low limit of the secondary parameter for the comparator.

command syntax: COMPArator:SLIMit <low limit>,<high limit>

<low limit>: NR1, NR2 or NR3 format, the low limit.

<high limit>: NR1, NR2 or NR3 format, the high limit.

Note:the high limit should be greater than the low limit, or the error message will be prompted.

e.g.: WrtCmd("COMP:SLIM 0.001,0.002")

query syntax: COMPArator:SLIMit?

return: <NR3>,<NR3><NL^END>

:Auxiliary BIN is used to set the auxiliary BIN ON/OFF of the BIN Count. The state of the auxiliary BIN can be queried.

command syntax:

| | | |
|--------------------------|---|-----|
| COMPArator:Auxiliary BIN | } | ON |
| | } | OFF |
| | } | 1 |
| | } | 0 |

char '0'(48) is equivalent to OFF

char '1'(49) is equivalent to ON .

e.g.: WrtCmd("COMP:ABIN ON")

query syntax: COMPArator:Auxiliary BIN?

return: <NR1><NL^END>

:SWAP is used to set the swap comparator mode ON/OFF of the main parameter and the secondary parameter.

e.g.:function:Cp-D; SWAP mode: ON; the function will be changed to D-Cp.At the same time, the limit setting on BIN 1 to 9 is the high limit and the low limit for D, the setting of BIN 2 is the Cp limit. The meaning is that if ON is selected, the main parameter and the secondary parameter will be compared by being interchanged; if OFF is selected, the parameters will be compared by the primary order. The state of the swap comparator mode can be queried.

command syntax:

| | | |
|-----------------|---|-----|
| COMPArator:SWAP | } | ON |
| | } | OFF |
| | } | 1 |
| | } | 0 |

char '1'(49) is equivalent to ON
 char '0'(48) is equivalent to OFF

e.g.: WrtCmd("COMP:SWAP ON")

query syntax: COMPArator:SWAP?

return: <NR1><NL^END>

:BIN:CLEAr is used to clear the setting limit of every BIN in the limit list.

command syntax: COMPArator:BIN:CLEAr

e.g.: WrtCmd("COMP:BIN:CLE")

:BIN:COUNT[:STATe] is used to set the BIN counter ON/OFF. The state of the BIN counter can be queried.

command syntax:

| | | |
|------------------------------|---|-----|
| COMPArator:BIN:COUNT[:STATe] | } | ON |
| | } | OFF |
| | } | 1 |
| | } | 0 |

char '1'(49) is equivalent to ON
 char '0'(48) is equivalent to OFF

e.g.: WrtCmd("COMP:BIN:COUN ON")

query syntax: COMPArator:BIN:COUNT[STATe]?

return: <NR1><NL^END>

:BIN:COUNT:DATA? is used to query the BIN count result.

query BIN: COMPArator:BIN:COUNT:DATA?

return: <BIN1 count>,<BIN2 count>,...,<BIN9 count>,<OUT OF BIN count>,
 <AUX BIN count><NL^END>

<BIN1-9 count>:NR1 format, is the count result of BIN 1 to 9.

<OUT OF BIN count>: NR1 format, is the count result of over the standard.

<AUX BIN count>: NR1 format, is the count result of the auxiliary BIN.

:BIN COUNT:CLEAr is used to clear all the count result.

command syntax: COMPArator:BIN:COUNT:CLEAr

e.g.: WrtCmd("COMP:BIN:COUN:CLE")

8.1.16 Mass MEMory subsystem command set

Mass MEMory subsystem command set is used to save and load the file.

Command hierarchical chart:

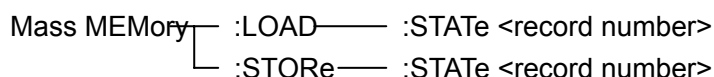

:LOAD:STATE is used to load the saved file.

command syntax: MMEMory:LOAD:STATE <value>

<value>:the file sequence number of 0 to 9 (NR1 format).

e.g.: WrtCmd("MMEM:LOAD:STAT 1");

:STORE:STATE is used to save the current setting for the instrument as one file.

command syntax: MMEMory:STOR:STATE <value>

<value>: the file sequence of 0 to 9 (NR1 format) .

e.g.: WrtCmd("MMEM:STOR:STAT 1");

8.2 The GPIB common command for TH2819A

| | | | |
|-------|-------|-------|-------|
| ●*RST | ●*TRG | ●*IDN | ●*TST |
| ●*ESE | ●*SRE | ●*ESR | ●*STB |
| ●*OPC | ●*CLS | | |

- *RST is used to reset the instrument.
command syntax: *RST
e.g.: WrtCmd("*RST");
- *TRG is used to trigger the measurement instrument, and transmit the test result to the output buffer.
command syntax: *TRG
e.g.: WrtCmd("*TRG");
- *CLS is used to clear the state register of the standard events and the service request.
command syntax: *CLS
e.g.: WrtCmd("*CLS");
- *IDN? is used to return the ID of the TH2819A.
query stynax: *IDN?
return: <manufacturer>,<model>,<firmware><NL^END>
<manufacturer> :manufacturer name.(e.g.:Tonghui).
<model> :the instrument type.(e.g.:TH2819A)
<firmware>:the software version.(e.g.:VER2.3.7)
e.g.: WrtCmd("*IDN?");
- *TST? is used to query self-checking, to perform internal self-checking and generate the error message report. For TH2819A, if the query result is "0", there is no error.
query syntax: *TST?
return: 0<NL^END>
0:0(NR1 format).
e.g.: WrtCmd("*TST?").
- *ESE (standard Event Status Enable command) is used to set the open bits of the

standard event status register). This query command returns the open bits setting state of the event status register.

Command syntax: *ESE<value>

<value> :NR1 format, the decimal for every bit of the state register.

The definition for event status register is shown in the table below.

| bit | description |
|-----|-----------------------------|
| 7 | Power On(PON) Bit |
| 6 | User Request(URQ) Bit |
| 5 | Command Error(EME) Bit |
| 4 | Execution Error(EXE) Bit |
| 3 | Device Dependent Error(DDE) |
| 2 | Query Error(QYE) Bit |
| 1 | Request Control(RQC) Bit |
| 0 | Operation Complete(OPC) Bit |

query syntax: *ESE?

return: <value><NL^END>

e.g.: WrtCmd("**ESE?");

- *SRE (Service Request Enable command) is used to set the open bits of the status byte register. This query command returns the current setting status of the status byte register.

command syntax: *SRE<value>

<value>: NR1 format, the decimal for the the status byte register.

The definition for the status byte register is shown in the table below.

| bit | description |
|-----|--|
| 7 | Operation Status Register Summary Bit |
| 6 | RQS(Request Service) Bit |
| 5 | Standard Event Status Register Summary Bit |
| 4 | MAV(Message Available) Bit |
| 3-0 | Always 0(zero): 0 |

query syntax: *SRE?

return: <value><NL^END>

e.g.: WrtCmd("**SRE?");

- *ESR? Returns the value of the event status register.

query syntax: *ESR?

return: <value><NL^END>

<value>: NR1 format, the decimal for the value of the event status register.

The definition for event status register is shown in the table below.

| bit | description |
|-----|-------------------|
| 7 | Power On(PON) Bit |

| | |
|---|---------------------------------|
| 6 | User Request(URQ) Bit |
| 5 | Command Error(EME) Bit |
| 4 | Execution Error(EXE) Bit |
| 3 | Device Dependent Error(DDE) Bit |
| 2 | Query Error(QYE) Bit |
| 1 | Request Control(RQC) Bit |
| 0 | Operation Complete(OPC) Bit |

e.g: WrtCmd("**ESR?");

- *STB? reads the value of the service status register. It has no effect to the value of the service status register.

query syntax: *STB?

return: <value><NL^END>

<value>:NR1 format, the decimal for the value of the status register.

The definition for the status word is shown in the table below:

| bit | discription |
|-----|--|
| 7 | Operation Status Register Summary Bit |
| 6 | RQS(Request Service) Bit |
| 5 | Standard Event Status Register Summary Bit |
| 4 | MAV(Message Available) Bit |
| 3-0 | Always 0(zero): 0 |

e.g.: WrtCmd("**STB?");

- *OPC is used to set the OPC bit of the event status register when TH2819A has finished the test task. At the same time, this command will notify the instrument that the buffer of the instrument shouble be set to 1(ASCII).

command syntax: *OPC

e.g.: OUTPUT 717;"*OPC"! ;set the OPC bit when the previous command has be finished.

query syntax: *OPC?

return: 1<NL^END>

char '1': 1(ASCII), 49 (decimal))

e.g.: WrtCmd("**OPC?")

Chapter 9 The description for Handler (optional)

This chapter will show you the Handler interface On TH2819A.

The TH2819 provides the Handler interface for you. The interface is mainly used for the output of the sorted result. The interface offers the communication signal and the signal for the output of the sorted result. The separator result is corresponding to the output of BIN 10. The design for the Handler interface is very smart with the status of the output signal can be defined according to your application target.

9.1 The technology description for TH2819A Handler

Table 9-1 shows the description for TH2819A HANDLER.

Table 9-1 the HANDLER description

| |
|---|
| <p>The output signal: low effective, open collector output, optoelectronic isolation</p> <p>Output signal judgment:</p> <p>BIN comparator: good, over the standard, not good</p> <p>list sweep comparator: IN/OUT for every sweep point and pass/fail for all the compared result.</p> <p>INDEX: ADC ended</p> <p>EOC: end of one test and comparison</p> <p>Alarm: alarm for circuit interruption</p> <p>The input signal: optoelectronic isolation</p> <p>Keylock: lock the keys on the front panel</p> <p>External Trigger: pulsewidth$\geq 1\mu\text{S}$</p> |
|---|

9.2 The operation description

9.2.1 The definition for the signal line

The Handler interface has 3 signal: comparison output, control output and control input. The signal line's definition for the BIN comparison and list sweep comparison is below:

Comparison signal lines:

- Comparison output signal
/BIN1 - /BIN9, /AUX, /OUT, /PHI(the main parameter is higher), /PLO(the main parameter is lower), /SREJ(the secondary parameter is not good). The signal line

distribution for comparison out is shown in figure 9-1.

- Control output signal
/INDEX(analog test finished signal), /EOM(test ended and the compared data effective), /ALARM(the circuit interruption)
- Control input signal
/EXT.TRIG(external trigger signal) , /Keylock(the key lock).

The signal distribution for the pins is described in table 9-2.

Table 9-2 The signal distribution for the pins

| pin | signal name | description |
|-----|-------------|--|
| 1 | /BIN1 | BIN sorted result /BIN(BIN number) output are all open collector output. |
| 2 | /BIN2 | |
| 3 | /BIN3 | |
| 4 | /BIN4 | |
| 5 | /BIN5 | |
| 6 | /BIN6 | |
| 7 | /BIN7 | |
| 8 | /BIN8 | |
| 9 | /BIN9 | |
| 10 | /OUT | |
| 11 | /AUX | |
| 12 | /EXT.TRIG | External trigger: when the trigger mode is EXT.TRIG, TH2819A will be triggered by the positive-edge in this pin. |
| 13 | | |
| 14 | EXT.DCV2 | External DC voltage 2: The DC provider pin for the optoelectronic coupling signal(/EXT_TRIG, /KeyLock, /ALARM, /INDEX, /EOM) |
| 15 | | |
| 16 | +5V | The internal power +5V: to use the internal power is not recommended. If you use the internal power, please ensure that the current is lower than 0.3A and the signal line is far from the disturbance source. |
| 17 | | |
| 18 | | |
| 19 | /PHI | The main parameter is higher: the test result is greater than the high limit in BIN1 to BIN9. |
| 20 | /PLO | The main parameter is lower: the test result is less than the low limit in BIN1 to BIN9. |

| | | |
|----------------|----------------|---|
| 21 | /SREJ | The secondary parameter is not good: the test result is not in the range of the high limit and the low limit. |
| 22 23 24 | NC NC NC | Not connect. |
| 25 | /KEY LOCK | When this single is effective, the keys in the front panel are locked. |
| 27 28 | EXT.DCV1 | The external DC voltage 1 : the pull-up DC power provider pin for optoelectronic coupling signal(/BIN-/BIN9,/AUX, /OUT, /PHI, /PLO, /SREJ). |
| 29 | /ALARM | When circuit is interrupted, /ALARM is effective. |
| 30 | /INDEX | When the analog test is finished and the UNKNOWN terminal can be connected to another DUT, /INDEX is effective. But the comparison signal is effective until /EOM is effective. |
| 31 | /EOM | End Of Measurement: when the test data and the compared result are effective, this signal is effective. |
| 32,33 | COM2 | The reference ground for external power EXTV2. |
| 34,35,36 | COM1 | The reference ground for external power EXTV1. |

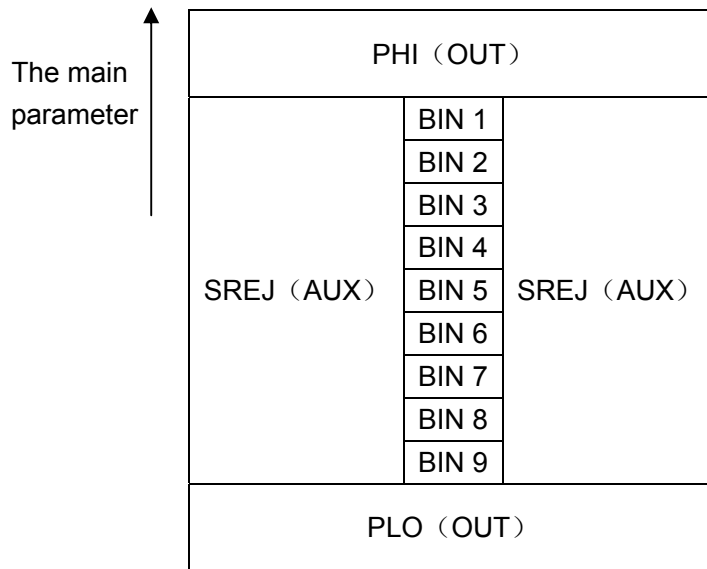

→
 The secondary parameter

Figure 9-1 the /PHI, /PLO, /SREJ signal distribution for BIN comparison

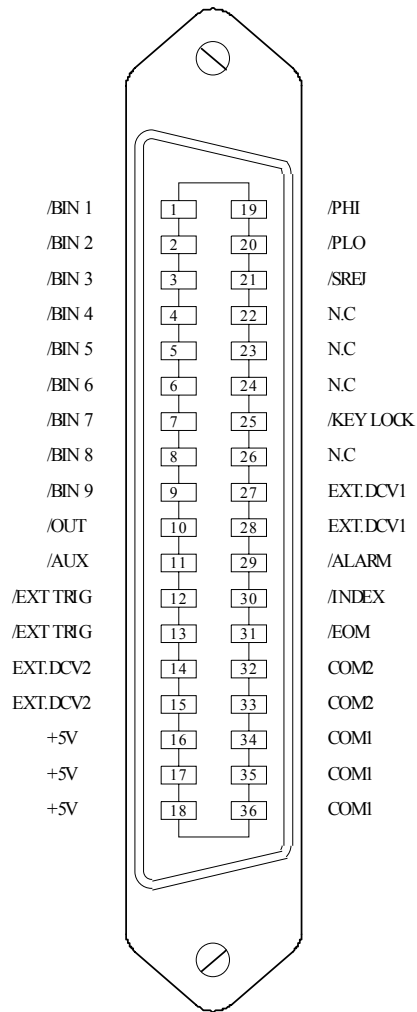

Note: the signal to /BIN1 - /BIN9, /OUT, /AUX, /PHI, /PLO and /SREJ in the list sweep comparison is different from that in the BIN comparison.

Figure 9-2 the pin definition for HANDLER

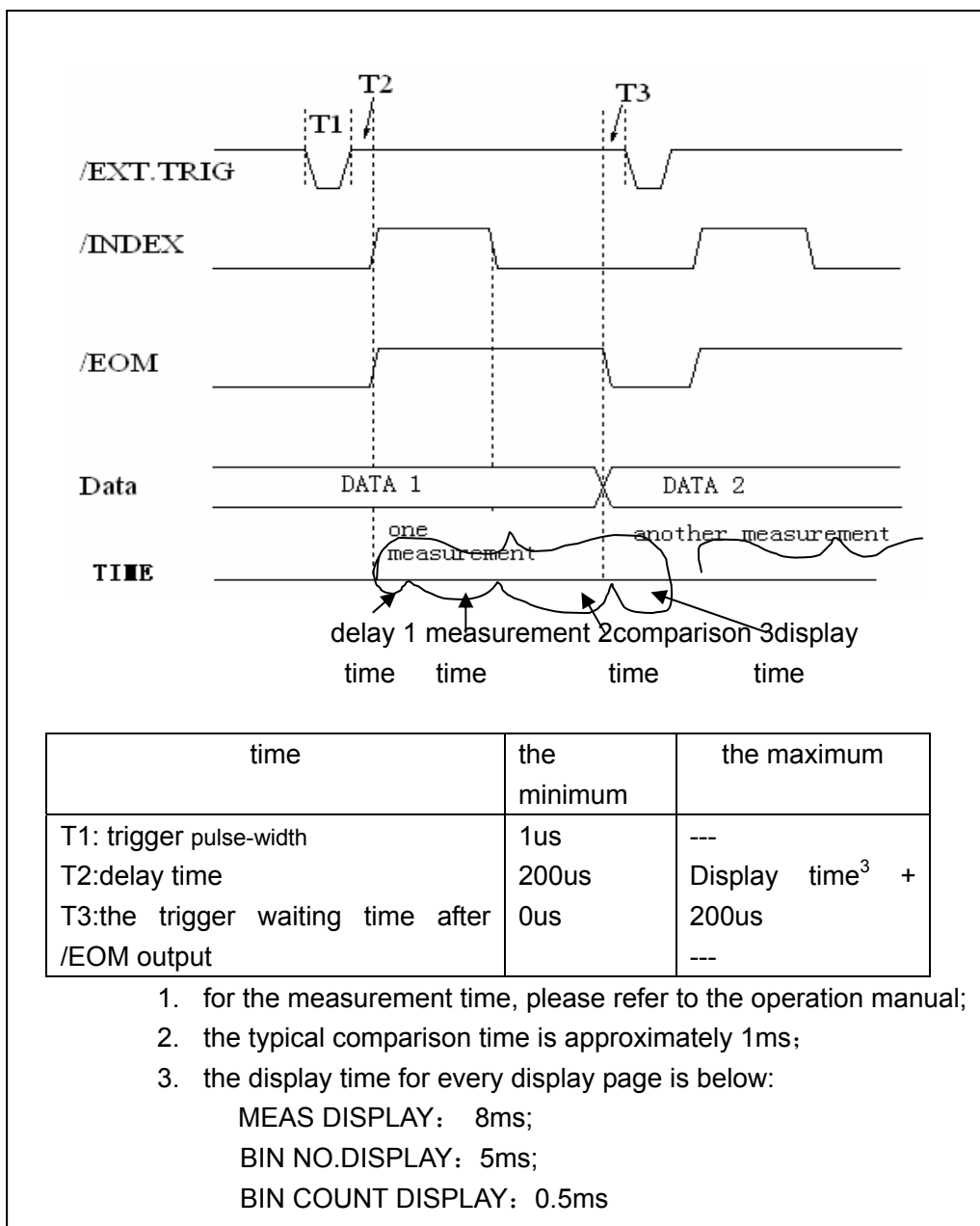

Figure 9-3 the timing chart

List sweep comparison signal line

The definition for list sweep comparison is different from that for the BIN comparison.

● Comparison output signal

/BIN-/BIN9 and /OUT show the IN/OUT (good or over the standard) judgment (figure 9-4). /AUX shows PASS/FAIL judgement.

When a sweep test is finished, these signal will be the output signal.

● Control

/INDEX(analog test finished), /EOM(the test ended).

The timing is below when /INDEX and /EOM are effective:

SEQ sweep mode:

/INDEX is defined as the effective signal when the last sweep point of the analog test is finished.

/EOM is defined as the effective signal when all the test results are effective after every list sweep task is finished.

STEP sweep mode:

/INDEX is defined as the effective signal when the analog test of every sweep point is finished.

/EOM is defined as the effective signal when the test and the comparison of every step are finished.

The pin distribution for list sweep is shown in table 9-3 and figure 9-2. (the pin definition for the list sweep comparison is the same to that for the BIN comparison). The timing chart is shown in figure 9-5.

Table 9-3 the pin distribute for the list sweep comparison

| pin | signal | description |
|-----|--------|--|
| 1 | /BIN1 | out of the limit of sweep point1 |
| 2 | /BIN2 | out of the limit of sweep point2 |
| 3 | /BIN3 | out of the limit of sweep point3 |
| 4 | /BIN4 | out of the limit of sweep point4 |
| 5 | /BIN5 | out of the limit of sweep point5 |
| 6 | /BIN6 | out of the limit of sweep point6 |
| 7 | /BIN7 | out of the limit of sweep point7 |
| 8 | /BIN8 | out of the limit of sweep point8 |
| 9 | /BIN9 | out of the limit of sweep point9 |
| 10 | /OUT | out of the limit of sweep point10 |
| 11 | /AUX | /AUX is defined as the effective signal when at least one is not good in the list. |
| 30 | /INDEX | SEQ: When the analog test of the last sweep point is finished and the UNKNOWN terminal can be connected to another DUT, /INDEX is effective. But the comparison signal is effective until /EOM is effective. STEP: When the analog test of the last sweep point is finished, /INDEX is effective. But the comparison signal is effective until /EOM is effective. |
| 31 | /EOM | Test ended: SEQ: when the test is finished and the compared results are effective, this signal is effective. STEP: When the test of every sweep point is finished, /EOM is |

| | | |
|--------|--|--|
| | | finished. the comparison result signal is effective until /EOM is effective. |
| others | | The definition is the same to that of the comparison. |

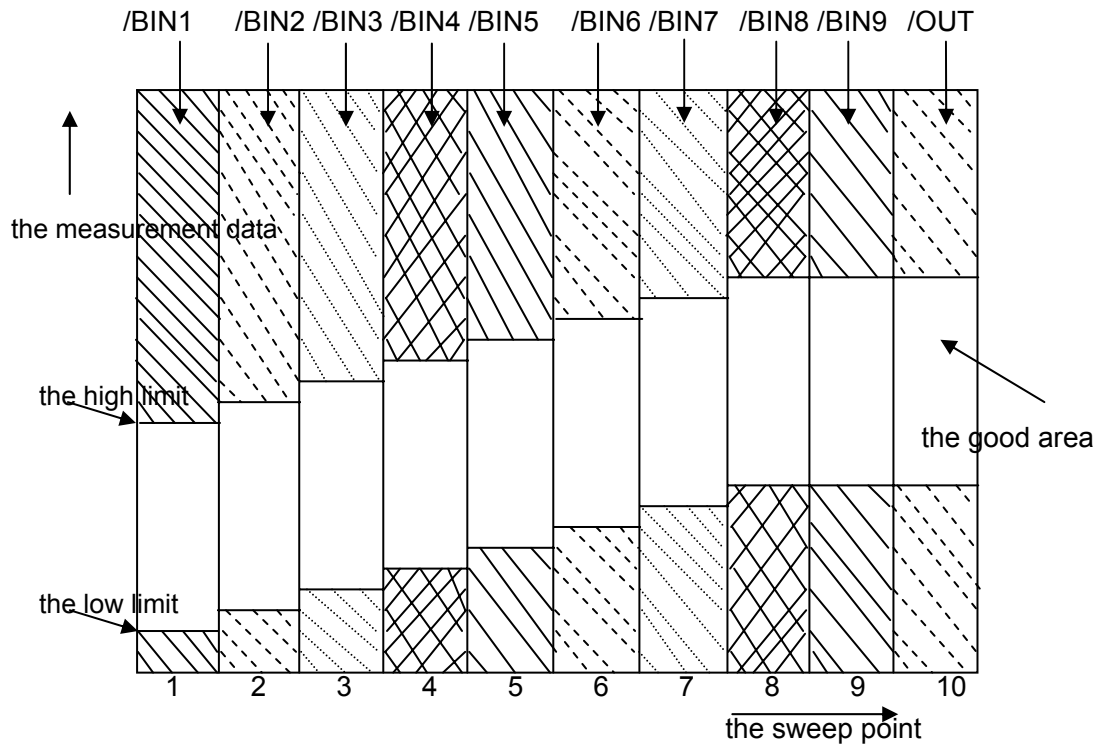

Figure 9-4 the signal area of the list sweep comparison

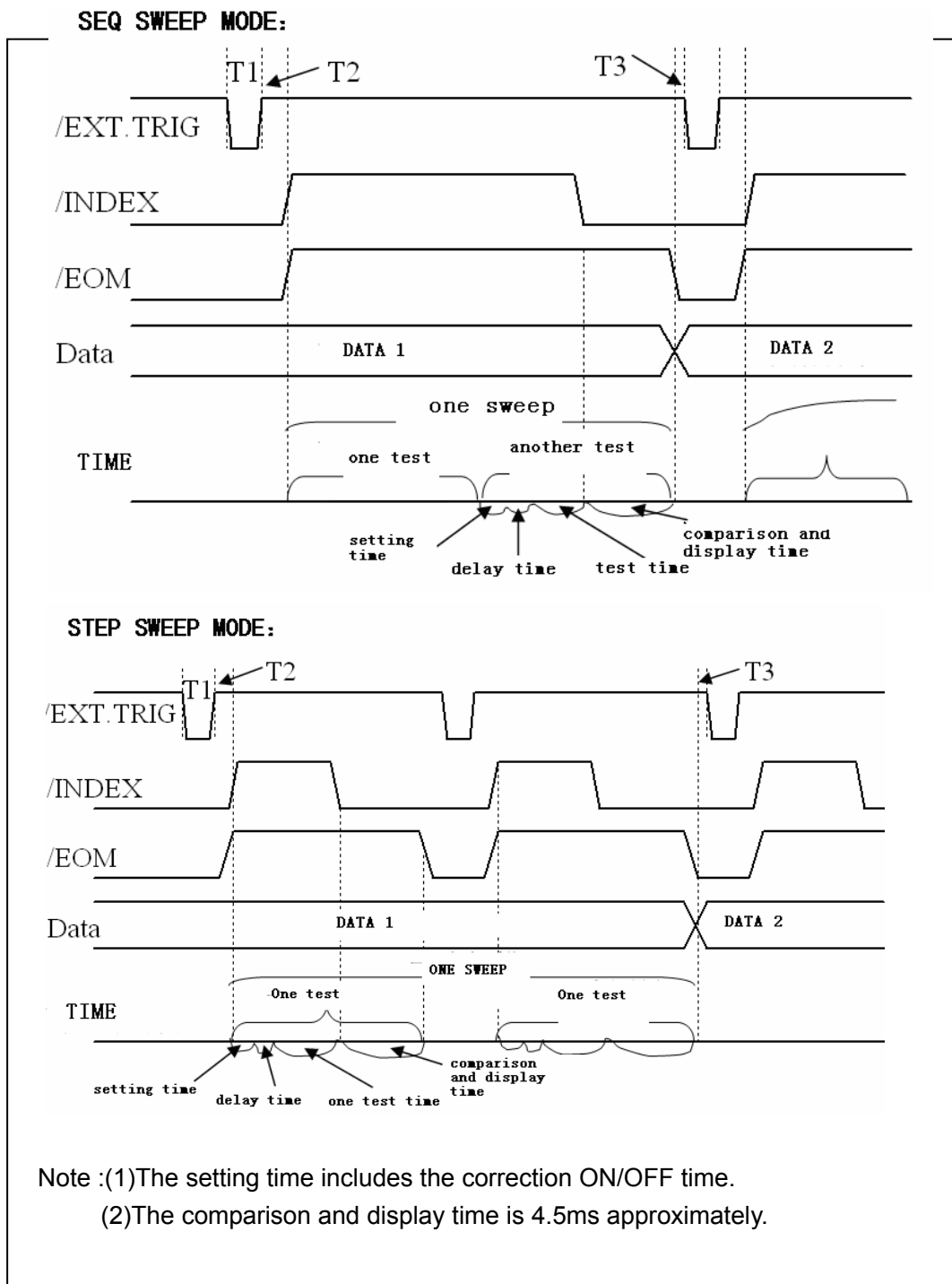

Figure 9-5 the time counting

9.2.2 Electrical feature

As it is shown above, the signal definition for the comparison and the list sweep comparison are different. But the electrical feature is same. So the description can be applied to BIN comparison and list sweep comparison.

DC isolation output: the DC isolation output (pin1 to pin16) generates the isolation by the optoelectronic coupler with the collector open. The output voltage on every line is set

by the pull-up resistance on the HANDLER interface board. The pull-up resistance is connected to the internal voltage (+5v). or the external voltage(EXTV:+5v).

The electrical feature of the DC isolation output can be divided into 2 types shown in Table 9-4.

Table 9-4 the electrical feature of the DC isolation output

| the output signal | the output rated voltage | | the maximum current | the reference ground for the circuit |
|--|--------------------------|-----------|---------------------|---|
| | LOW | HIGH | | |
| compared signal /BIN1 - /BIN9 /AUX /OUT /PHI /PLO | $\leq 0.5V$ | +5V--+24V | 6mA | Internal pull-up voltage: TH2819A GND EXTV1: COM1 |
| control signal /INDEX /EOM /ALARM | $\leq 0.5V$ | +5V--+24V | 5mA | Internal pull-up voltage : TH2819A GND EXTV2: COM2 |

9.2.3 HANDLER Interface board circuit

The output circuit for the comparison result is shown in the figure 9-6 below.

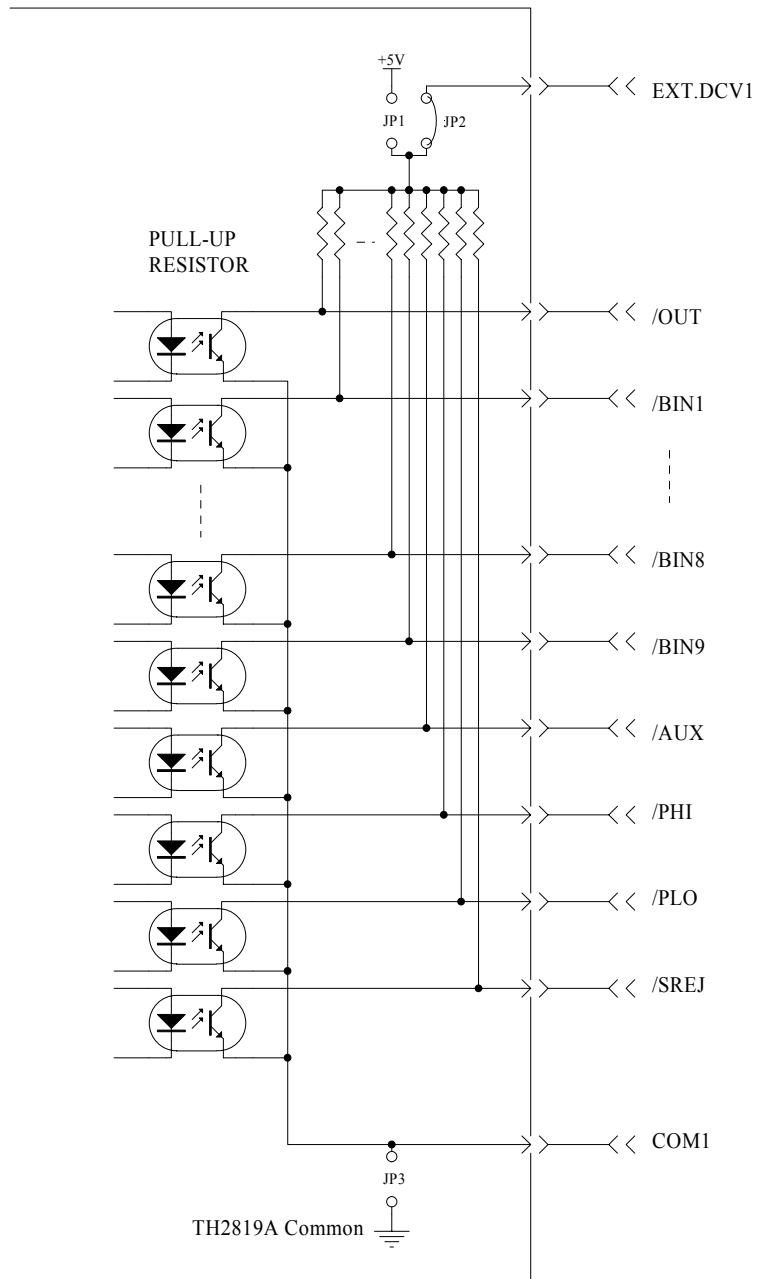

Figure 9-6 the output circuit for the comparison result

The output circuit for control signal is shown in the figure 9-7 below.

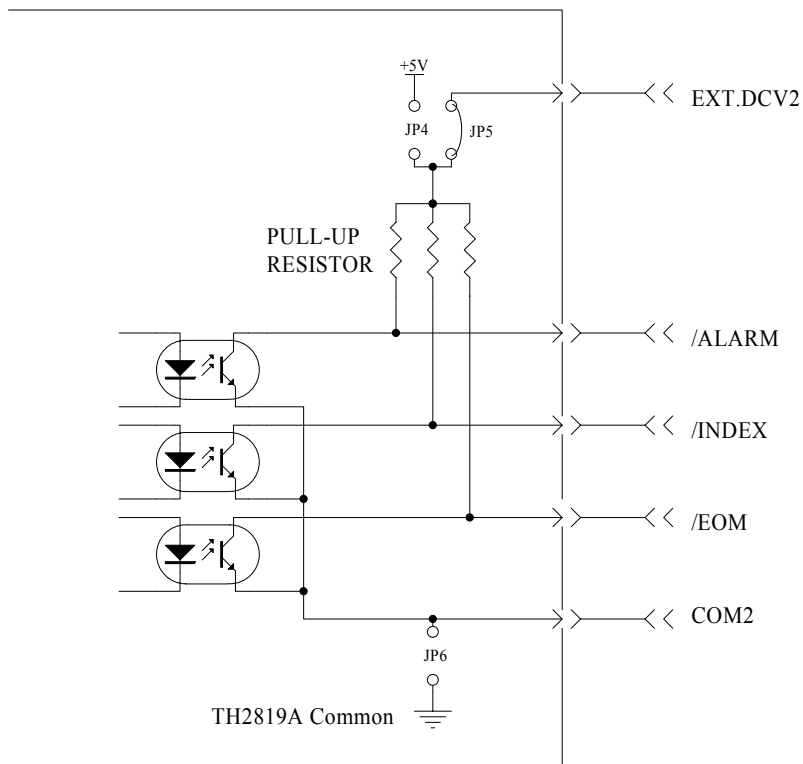

Figure 9-7 the output circuit for control signal

The input circuit for control signal is shown in the figure 9-8 below.

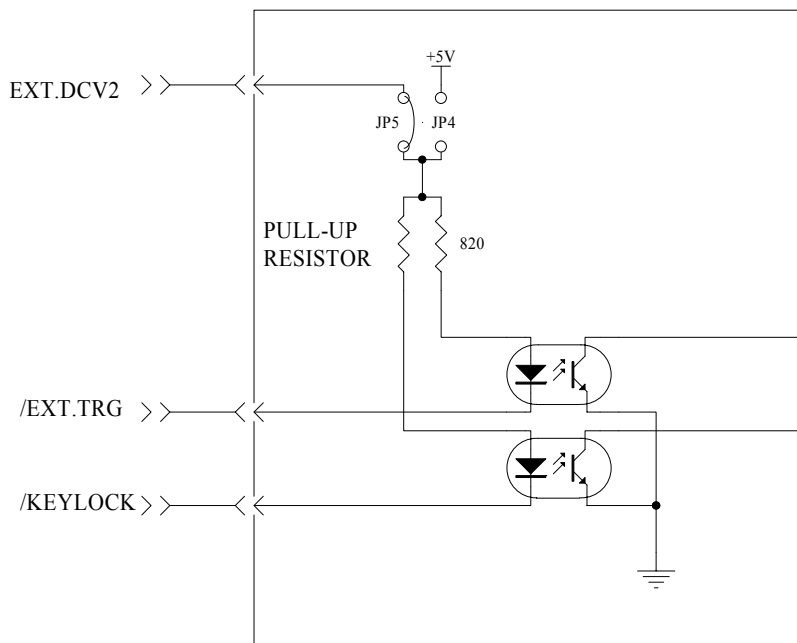

Figure 9-8 the input circuit for control signal

9.2.4 operation

Before you use the HANDLER function, you should ensure that your instrument has install the HANDLER interface board. The following procedure will show you how to use the interface comparison and the list sweep comparison.

The procedure for comparison setting :

- (1) Press the softkey [LIMIT TABLE]. LIMIT TABLE SETUP page will be displayed.
- (2) Set the standard value and the high limit and the low limit in LIMIT TABLE SETUP.
Refer to the LCR menu key description to see more details.
- (3) Move the cursor to COMP field. The softkey area will display :
 - ON
 - OFF
- (4) Press the softkey ON to enable the comparison function.
- (5) Press [LCRZ], and then press the softkey BIN NO. or BIN COUNT, the DUT will be tested; at the same time, you can set the counter for the DUT and the auxiliary.

Note: COMP ON/OFF can be set in BIN COUNT page.

The procedure for list sweep comparison:

- (1) Press LIST SETUP, LIST SWEEP SETUP page will be displayed.
- (2) Set the sweep mode, sweep frequency point, reference value, the high limit and the low limit. Refer to the LCR menu key description to see more details.
- (3) Press [LCRZ]. and then press the softkey LIST SWEEP, LIST SWEEP DISP page will be displayed. Refer to the LCR menu key description to see more details.

Note: the following methods can be used to improve the speed:

- (1) Set the range to the maximum that the capacitance may be, and lock this range.
- (2) Set Vm: OFF and Im: OFF in the MEAS SETUP page.
- (3) Test the DUT in the BIN COUNT page.