

OPERATION MANUAL

TH2811D LCR Meter

<u>CHAPTER 1 PREPARATION.....</u>	<u>1-6</u>
1.1 UNPACKING AND INSPECTION.....	1-6
1.2 POWER REQUIREMENTS	1-6
1.3 LINE VOLTAGE AND FUSE SELECTION	1-6
1.4 OPERATION ENVIRONMENT	1-7
1.5 USE TEST FIXTURE	1-7
1.6 WARM-UP AND CONTINUOUS WORKING TIME.....	1-7
1.7 OTHER FEATURES	1-8
<u>CHAPTER 2 PANEL DESCRIPTION.....</u>	<u>2-9</u>
2.1 A TOUR OF THE FRONT PANEL.....	2-9
2.2 A TOUR OF THE REAR PANEL.....	2-10
2.3 DISPLAY AREA DEFINITION.....	2-11
<u>CHAPTER 3 OPERATION.....</u>	<u>3-13</u>
3.1 POWER ON	3-13
3.2 PARAMETER SETUP	3-13
3.3 TEST FREQUENCY	3-14
3.4 TEST SIGNAL LEVEL	3-15
3.5 SIGNAL SOURCE OUTPUT IMPEDANCE.....	3-15
3.6 MEASUREMENT SPEED	3-15
3.7 EQUIVALENT CIRCUIT MODE	3-16
3.7.1 Series and Parallel Circuits Setup	3-16
3.7.2 How to Select the Measurement Circuit Mode	3-16
3.8 MEASUREMENT RANGE	3-17
3.9 OPEN CORRECTION	3-18
3.10 SHORT CORRECTION	3-19
<u>CHAPTER 4 SPECIFICATIONS.....</u>	<u>4-20</u>
4.1 MEASUREMENT PARAMETERS	4-20
4.2 EQUIVALENT MEASUREMENT CIRCUIT MODE	4-20
4.3 MEASUREMENT RANGE	4-21
4.4 MEASUREMENT TERMINALS	4-21
4.5 MEASUREMENT SPEED	4-22

4.6 BASIC ACCURACY	4-22
4.6.1 Maximum and Minimum Values of Measurement Parameters Affecting Accuracy	4-22
4.6.2 Measurement Speed Factor k_s	4-23
4.6.3 Measurement Voltage Level Factor k_v	4-23
4.6.4 Measurement Frequency Factor k_f	4-23
4.7 MEASUREMENT FREQUENCY	4-23
4.8 TEST SIGNAL LEVEL	4-23
4.9 OUTPUT IMPEDANCE	4-23
4.10 DISPLAY RANGE	4-23
4.11 CORRECTION FUNCTION	4-24
4.12 RANGE MODE	4-24

Manual Print History

The manual print history shown below lists all the printing dates and editions. The printing date changes when a new edition is released. The latest editions can be downloaded from our website.

March 2006 First Edition
December 2007 Second Edition

Warranty

This Tonghui instrument product is warranted against defects in material and workmanship for a period of two years from the date of shipment. Other items such as test fixtures, test cables are warranted for 90 days from the date of shipment. During the warranty period, we will, at our option, either repair or replace products which prove to be defective.

For warranty service or repair, this product must be returned to a service facility designated by Tonghui. Purchaser shall prepay shipping charges to Tonghui and Tonghui shall pay for the return of the product to Buyer. However, Buyer shall pay all shipping charges, duties, taxes, and any other charges for products returned to Tonghui from another country.

Limitation of Warranty

This warranty does not apply to defects resulting from improper or inadequate maintenance and care by Buyer, Buyer-supplied software or interfacing, unauthorized modification or misuse, operation outside of the environmental specifications for the product, or improper site preparation or maintenance.

No other warranty is expressed or implied. Tonghui specially disclaims the implied warranties of merchantability and fitness for a particular use.

Tonghui's responsibility to repair or replace defective products is the sole and exclusive remedy provided to the customer for breach of this warranty. Tonghui shall not be liable for any direct, indirect, special, incidental, or consequential damages, whether based on contract, tort, or any other legal theory.

Safety Precautions

The following safety precautions must be observed to avoid injury and prevent damage to this product or any products connected to it. To avoid potential hazards, read the operating information carefully before using the product and use this product only as specified.

NOTE: *This product complies with INSTALLATION CATEGORY 1 as well as POLLUTION DEGREE 2. This product is an INDOOR USE product.*

- Ground the Instrument

Before operating the instrument, make sure the instrument chassis is grounded with the 3-pole power cable.

- Don't operate in an explosive atmosphere

To prevent explosion or fire, don't operate the instrument in the presence of inflammable gases or fumes.

- Use the proper fuse

Replace the broken fuse with the same type and rating for continuous protection against fire hazard.

- Keep away from live circuits

Don't remove the instrument covers when operating the instrument. Component replacement and internal adjustment can only be done by qualified personnel. Don't replace components with the power cable connected. Dangerous voltage may remain even after the power cable has been disconnected. Always remove the power cable from the instrument and discharge circuits before touching them.

Chapter 1 Preparation

This chapter provides the information necessary for performing an incoming inspection and setting up the instrument before operation.

1.1 Unpacking and Inspection

Thank you for purchasing and using our product. Inspect the shipping container for damage. If the shipping container or cushioning material is damaged, it should be kept until the contents of the shipment have been checked for completeness and the TH2811D has been checked mechanically and electrically. The contents of the shipment should be as listed in the packing list. If the contents are incomplete, if there is mechanical damage or defect, if the instrument does not work normally, notify our company or our local representative. Keep the shipping container and packing material for future use such as returning for re-calibration or service.

1.2 Power Requirements

- (1) Voltage: 198 to 242 Vac, or 99 to 121Vac
- (2) Frequency: 47.5 to 63 Hz
- (3) Power: 20 VA maximum
- (4) In accordance with internal safety standards, this instrument is equipped with a three-wire power cable. When connected to an appropriate ac power outlet, this cable grounds the instrument frame.
- (5) The instrument is carefully designed in order to reduce the disturbance induced by AC power supply, however, low noise environment is recommended. Sometimes a power source filter is needed.

Warning: *For protection from electrical shock, the power cable ground must not be defeated. The power plug must be plugged into an outlet that provides a protective earth ground connection.*

1.3 Line Voltage and Fuse Selection

Figure 1-1 illustrates the line voltage selection switch on the instrument's rear panel. Before connecting the instrument to the power source, make sure that the correct fuse has been installed and the Line Voltage Selection Switch is correctly set.



Figure 1-1. Line Voltage Selector

The instrument has been equipped with the 200 mA fuse before leaving factory. Use only fuses with the required current rating and of the specified type as replacements. Do not use a mended fuse or short-circuit the fuse-holder in order to by-pass a blown fuse. Find out what caused the fuse to blow!

1.4 Operation Environment

- (1) Please do not operate the instrument in places where there is dusty, vibrant, under direct sunlight, or where there is corrosive air.
- (2) In order to maintain good measurement accuracy, the TH2811D must be operated under the following environment conditions:
Temperature: 0°C ~ 40°C
Humidity: ≤ 75% RH at 40°C.
- (3) The instrument is carefully designed in order to reduce the disturbance induced by AC power supply, however, low noise environment is recommended. Sometimes a power source filter is needed.
- (4) Please store the instrument in the place where the temperature is between 5°C and 40°C, humidity is less than 85% RH. If the instrument will not be put in use for a time, please have it properly packed with its original box or a similar box for storage.
- (5) The instrument, especially the test leads, should be kept far away from strong electromagnetic field to avoid interference with measuring precision.

1.5 Use Test Fixture

Original test fixture and test clip leads should be used in order to ensure correct and accurate measuring results. At the same time, test fixture, test clip leads and pins of DUT should be kept clean in order to connect well between DUT and test fixture. Test fixture and test clip leads are connected to Hcur、Hpot、Lcur and Lpot 4 terminals on the front panel. For DUT which has shield, please connect the shield to the ground terminal “⊥” of the instrument.

1.6 Warm-up and Continuous Working Time

Warm up the instrument for a minimum time of 15 minutes in order to ensure measuring precision.

Continuous working time should be less than 16 hours.

1.7 Other features

- (1) Power consumption: $\leq 20\text{VA}$
- (2) Dimension(W*H*D) : 350mm*110mm*340mm
- (3) Weight: about 3.5kg

Chapter 2 Panel Description

This chapter provides information including a tour of the front and rear panel and display area definition, which will help you to quickly learn how to operate the TH2811D.

2.1 A Tour of the Front Panel

Figure 2-1 shows the brief description of each key on the TH2811D's front panel.

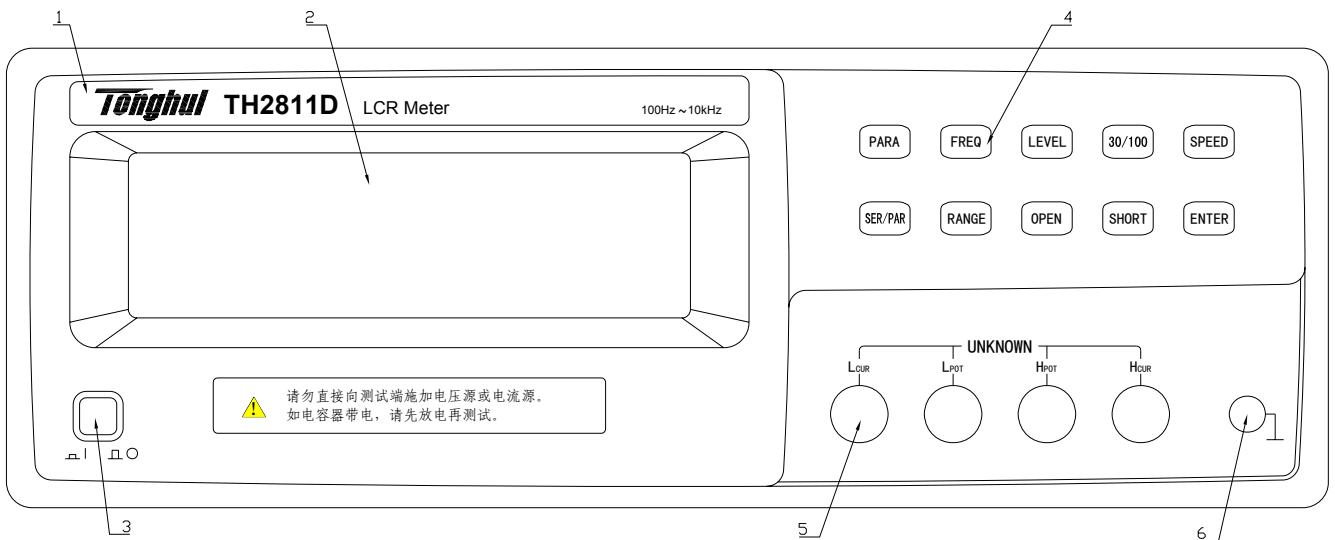

Figure 2-1 Front Panel Overview

(1) Brand and Model

Brand and model of instrument

(2) LCD

The Liquid Crystal Display displays the measurement results, test conditions, etc.

(3) Power On/Off

Power on/off switch. In the “ON” position all operating voltages are applied to the instrument. In the “OFF” position NO operating voltages are applied to the instrument.

(4) Keys

- a) **PARA** key: the selection key of test parameter combinations.
- b) **FREQ** key: the setup key of test frequency.
- c) **LEVEL** key: the selection key of test voltage level.
- d) **30/100** key: the selection key of signal output resistance.

- e) **SPEED** key: the selection key of measurement speed.
- f) **SER/PAR** key: the selection key of serial/parallel equivalent circuit mode.
- g) **RANGE** key: the setup key of AUTO/HOLD ranging mode.
- h) **OPEN** key: the key of open correction.
- i) **SHORT** key: the key of short correction.
- j) **ENTER** key: the confirming key of short/open correction.

(5) UNKNOWN Terminals

There are 4 unknown terminals used to connect a 4-terminal test fixture or test leads for measuring the device under test.

- H_{CUR}**: High current
- H_{POT}**: High potential
- L_{POT}**: Low potential
- L_{CUR}**: Low current

(6) Frame Terminal

This is the frame terminal which is tied to the instrument's chassis and which can be used for measurements that require guarding.

2.2 A Tour of the Rear Panel

Figure 2-2 shows a brief description of the TH2811D's rear panel.

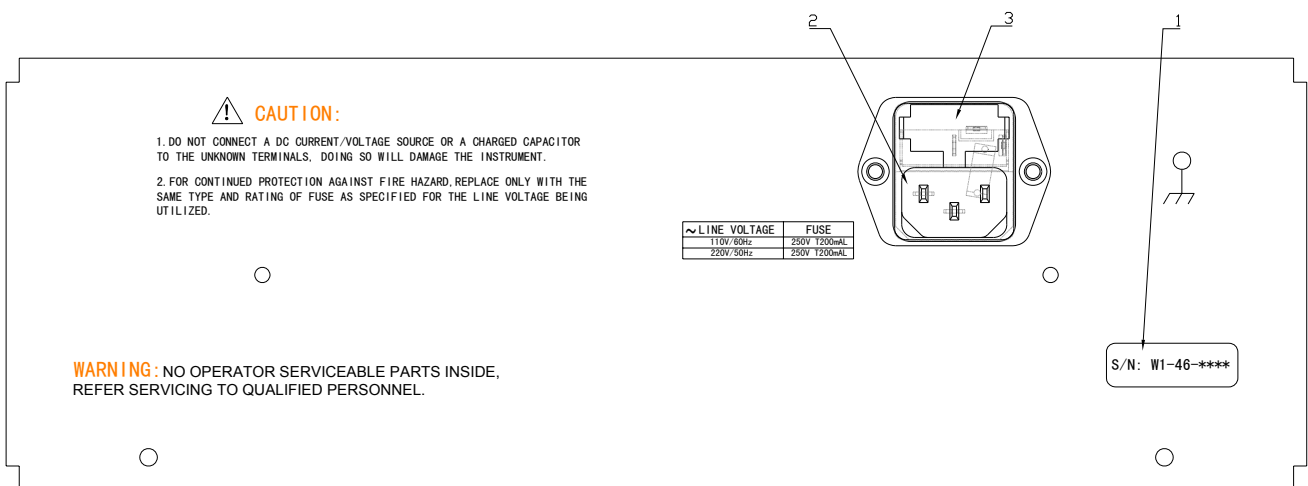

Figure 2-2 Rear Panel Overview

(1) Name Plate

Name plate is used to provide the information of date, model, lot number and manufacturer etc.

(2) Line Input Receptacle

AC power cord receptacle.

(3) Fuse Holder and Line Voltage Selector

Fuse holder and line voltage selector for TH2811D's power supply.

(4) Line Voltage Selector

The switch used to match the TH2811D to the AC operating voltage being use. Refer to chapter 1 to determine the correct operating voltage.

2.3 Display Area Definition

The display area on the LCD is divided into the following areas shown in Figure 2-3.

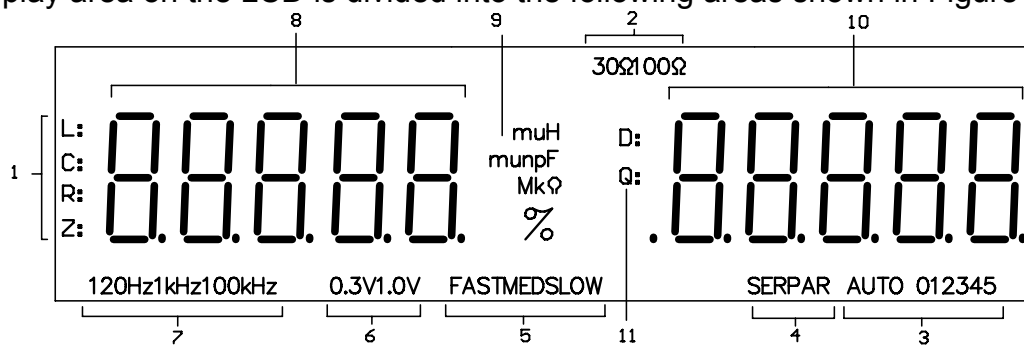

Figure 2-3 Display Area Definition

(1) Primary Parameter Indication

Indicate the current measuring primary parameter user selected.

“L:” is on: Inductance is measured and displayed.

“C:” is on: Capacitance is measured and displayed.

“R:” is on: Resistance is measured and displayed.

“Z:” is on: Impedance is measured and displayed.

(2) Signal Source Output Impedance Indication

“30Ω” is on: Signal source output impedance is 30 Ω.

“100Ω” is on: Signal source output impedance is 100 Ω.

(3) Range Indication

Indicate the current ranging mode and the current range number.

“AUTO” is on: Range AUTO

“AUTO” is off: Range HOLD

(4) Equivalent Circuit Mode Indication

“SER” is on: Series equivalent circuit mode.

“PAR” is on: Parallel equivalent circuit mode.

(5) Measurement Speed Indication

“FAST” is on: Fast measurement speed

“MED” is on: Medium measurement speed

“SLOW” is on: Slow measurement speed

(6) Test Signal Level Indication

“**0.3 V**” is on: The current test signal voltage is 0.3 V.

“**1.0 V**” is on: The current test signal voltage is 1.0 V.

(7) Test Signal Frequency Indication

“**100 Hz**” is on: The current test signal frequency is 100 Hz.

“**120 Hz**” is on: The current test signal frequency is 120 Hz.

“**1 kHz**” is on: The current test signal frequency is 1 kHz.

“**10 kHz**” is on: The current test signal frequency is 10 kHz.

(8) The Primary Parameter Display

Display the current measurement result of the primary parameter.

(9) Unit of The primary Parameter Indication

Indicate the current unit of measurement result of the primary parameter.

Unit of inductance: **μH, mH, H.**

Unit of capacitance: **pF, nF, μF, mF.**

Unit of resistance/impedance: **Ω, kΩ, MΩ.**

(10) The Secondary Parameter Display

Display the current measurement result of the secondary parameter.

(11) The Secondary Parameter Indication

Indicate the current measuring secondary parameter user selected.

Chapter 3 Operation

3.1 Power On

- 1) Press power switch to turn on the instrument.
- 2) Version number of the instrument is first displayed on the LCD screen.
- 3) The instrument enters the measurement status after a short delay. Figure 3.1 shows the information displayed in measurement status. It may be different with the actual display due to different measurement setup.
- 4) The instrument restores the measurement setup when the instrument was turned off last time excluding range number.

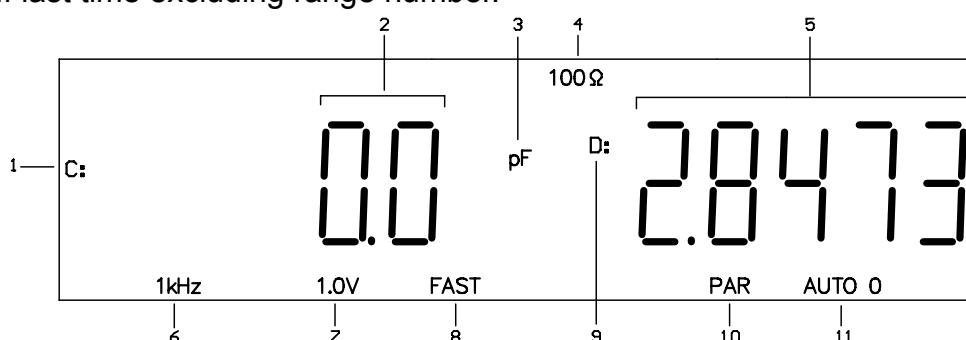

Figure 3.1 LCD Display in Measurement Status

Description of Measuring LCD Display:

- 1) Primary parameter: C
- 2) Measurement result of primary parameter displayed
- 3) Unit of primary parameter: pF
- 4) Signal source output resistance: 100Ω
- 5) Measurement result of secondary parameter displayed
- 6) Measurement frequency: 1kHz
- 7) Signal level: 1.0V
- 8) Measurement speed: FAST
- 9) Secondary parameter: D (dissipation factor)
- 10) Parallel equivalent circuit: PAR
- 11) Range: AUTO 0

3.2 Parameter Setup

TH2811D measures two components of the complex impedance parameters at the same time in a measurement cycle. The primary and secondary measurement parameters are listed as follows.

■ Primary Parameter

- L: Inductance
- C: Capacitance
- R: Resistance
- |Z|: Absolute value of impedance

■ Secondary Parameter

- D: Dissipation factor
- Q: Quality factor

$|Z|$ is the absolute value of impedance, so it is always a positive value; While L/ C/ R maybe a positive value or sometimes a negative value.

When measurement function is C-D and the primary parameter measurement result is negative, this means the component under test is probably an inductor.

When measurement function is L-Q and the primary parameter measurement result is negative, this means the component under test is probably a capacitor.

When measurement function is R-Q and the measurement result of resistor is negative, this is due to over zero correction, please perform open and short correction correctly.

TH2811D provides 4 combinations of primary and secondary parameters:

- L-Q
- C-D
- R-Q
- Z-Q

Perform the following steps to set the measurement function.

1. Assume that current measurement function is L-Q. Primary parameter indication is “L:”, secondary parameter indication is “Q:”.
2. Press **PARA** key, measurement function is changed to C-D. Primary parameter indication is “C:”, secondary parameter indication is “D:”.
3. Press **PARA** key, measurement function is changed to R-Q. Primary parameter indication is “R:”, secondary parameter indication is “Q:”.
4. Press **PARA** key, measurement function is changed to Z-Q. Primary parameter indication is “Z:”, secondary parameter indication is “Q:”.
5. Keep on pressing **PARA** key, until the measurement function required is displayed.

3.3 Test Frequency

TH2811D provides 4 typical frequency points: 100 Hz, 120 Hz, 1 kHz and 10 kHz. The current test frequency is displayed on the bottom area of LCD.

Perform the following steps to set the test frequency.

1. Assume the current test frequency of the instrument is 100Hz. “100Hz” is displayed at the bottom of LCD.
2. Press **FREQ** key, test frequency is changed to 120 Hz, and “120Hz” is displayed at the bottom of LCD.
3. Press **FREQ** key, test frequency is changed to 1 kHz, and “1kHz” is displayed at the bottom of LCD.
4. Press **FREQ** key, test frequency is changed to 10 kHz, and “10kHz” is displayed at the bottom of LCD.
5. Press **FREQ** key, test frequency is changed back to 100Hz, and “100Hz” is displayed at the bottom of LCD.
6. Keep on pressing **FREQ** key, until the test frequency required is displayed at the bottom of LCD.

3.4 Test Signal Level

TH2811D provides 2 kinds of test signal voltage levels: $0.3 V_{RMS}$ and $1.0 V_{RMS}$.

Perform the following steps to set the test signal level.

1. Press **LEVEL** key, test signal level is changed between 0.3V and 1.0V.
2. The currently selected test signal level is displayed at the bottom of LCD.

3.5 Signal Source Output Impedance

TH2811D provides two different signal output impedances: 30Ω and 100Ω . The measurement current through the DUT will be different with different signal output impedance under the test same signal voltage level. The current sensitive components, for example the inductors with cores, will get different measurement results under different signal resistance. In order to be compatible with other well-known instruments in the world, use the same signal resistance for each instrument.

Perform the following steps to set the signal resistance

1. Press **30/100** key to set the source output impedance between 30Ω and 100Ω .
2. The currently selected impedance is displayed on the LCD.

3.6 Measurement Speed

TH2811D provides 3 kinds of measurement speeds: FAST, MED and SLOW. Generally, a slow measurement speed will result in more stable and accurate measurement results.

- FAST: 10 meas/sec
- MED: 4.0meas/sec
- SLOW: 2.5meas/sec

Perform the following steps to set the measurement speed

1. Assume the current measurement speed is FAST, and “**FAST**” is displayed at the bottom of LCD.
2. Press **SPEED** key, the measurement speed is changed to MED, and “**MED**” is displayed on the bottom LCD.
3. Press **SPEED** key, the measurement speed is changed to SLOW, and “**SLOW**” is displayed at the bottom of LCD.
4. Press **SPEED** key, the measurement speed is changed back to FAST, and “**FAST**” is displayed at the bottom of LCD.
5. Keep on pressing **SPEED** key, until the measurement speed required is displayed at the bottom of LCD.

3.7 Equivalent Circuit Mode

3.7.1 Series and Parallel Circuits Setup

TH2811D provides the series and parallel equivalent modes for measuring the L, C, and R.

Perform the following steps to set the equivalent circuit mode

1. Press **SER/PAR** key to switch between the series mode and parallel mode.
2. The current equivalent circuit mode is displayed at the bottom of LCD.

3.7.2 How to Select the Measurement Circuit Mode

■ **Guide lines for selecting the capacitance measurement circuit mode.**

Small capacitance yields large reactance, which implies that the effect of the parallel resistance has relatively more significance than that of series resistance. The low value of the series resistance has negligible significance compared with the large capacitive reactance, so the parallel circuit mode should be used.

Large capacitance yields small reactance, which implies that the effect of the series resistance has relatively more significance than that of parallel resistance. The large value of the parallel resistance has negligible significance compared with the low capacitive reactance, so the series circuit mode should be used.

The following is a rule of thumb for selecting the circuit mode according to the impedance of the capacitor.

- ◇ Above approx. $10\text{k}\Omega$: use parallel circuit mode
- ◇ Below approx. 10Ω : use series circuit mode
- ◇ Between above values: follow the manufacturer's recommendation

■ **Guide lines for selecting the inductance measurement circuit mode.**

The reactance of a large inductance at a given frequency is relatively large (compared with that of a small inductance), so the parallel resistance becomes more significant than the series component. So, a measurement in the parallel equivalent circuit mode is more suitable.

Conversely, for low values of inductance the reactance becomes relatively small (compared with that of a large inductance), so the series resistance component is more significant. So, the series equivalent circuit mode is the appropriate choice.

The following is a rule of thumb for selecting the circuit mode according to the impedance of the inductor.

- ◇ Below approx. 10Ω : use series circuit mode
- ◇ Above approx. $10\text{k}\Omega$: use parallel circuit mode
- Between above values: follow the manufacturer's recommendation

3.8 Measurement Range

When signal resistance is 100Ω, TH2811D provides 5 measurement ranges: 30Ω, 100Ω, 1kΩ, 10kΩ and 100kΩ. Table 3-1 shows the effective measuring range for each measurement range.

When signal resistance is 30Ω, TH2811D provides 6 measurement ranges: 10Ω, 30Ω, 100Ω, 1 kΩ, 10 kΩ and 100 kΩ. Table 3-2 shows the effective measuring range for each measurement range.

When the measurement range is set manually, the optimum measurement range should be selected by matching the DUT's impedance to the effective measuring range shown in Table 3-1 and Table 3-2. When the measurement range is set to AUTO, the optimum measurement range is automatically selected according to the impedance of each DUT, regardless of what kind of component is measured, a capacitor, a resistor or an inductor.

Table 3-1 Effective Measuring Range for Each Range Under 100Ω Output Impedance

No.	Range Resistor	Effective Measuring Range
0	100 kΩ	100kΩ-100MΩ
1	10 kΩ	10kΩ-100kΩ
2	1 kΩ	1kΩ-10kΩ
3	100Ω	50Ω-1kΩ
4	30Ω	0Ω-50Ω

Table 3-2 Effective Measuring Range for Each Range Under 10Ω Output Impedance

No.	Range Resistor	Effective Measuring Range
0	100 kΩ	100kΩ-100MΩ
1	10 kΩ	10kΩ-100kΩ
2	1 kΩ	1kΩ-10kΩ
3	100Ω	100Ω-1kΩ
4	30Ω	15Ω-100Ω
5	10Ω	0Ω-15Ω

Perform the following steps to set the measurement range

1. Press **RANGE** key to switch between AUTO and HOLD.
2. When the range is selected to be HOLD, "AUTO" will not appear at the bottom of LCD, and only the currently selected range number displays.
3. When the range is selected to be AUTO, "AUTO n" appears at the bottom of LCD, where "n" is the currently selected range number.

Notice:

In measurement range "HOLD" mode, if the measured impedance is out of the effective measuring range or display range of the current fixed range, "-----" will be displayed instead of the measurement results.

An example of how to calculate the optimum measurement range:

For a capacitor DUT, if $C=210\text{nF}$, $D=0.0010$, and measurement frequency $f=1\text{ kHz}$. We can calculate the impedance of the capacitor as follows.

$$Z_x = R_x + \frac{1}{j2\pi f C_x}$$
$$|Z_x| \approx \frac{1}{2\pi f C_x} = \frac{1}{2 \times 3.1416 \times 1000 \times 210 \times 10^{-9}} \approx 757.9\Omega$$

According to above Table 3-1 or Table 3-2, we can find that the optimum measurement range is range 3.

3.9 Open Correction

TH2811D's OPEN correction eliminates the effect of stray admittance (G,B) in parallel with the device under test, such as stray capacitance.

Perform following steps for the open and short correction:

1. Press **OPEN** key to select open correction function.
2. The information shown in Figure 3-2 will be displayed. "**OPEN**" flashes.

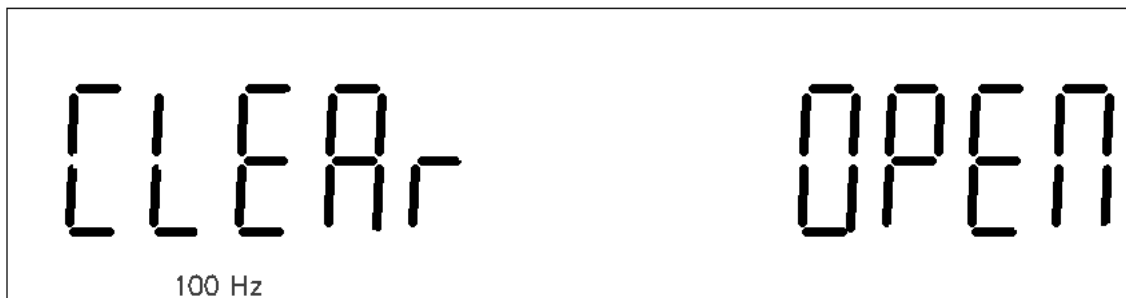

Figure 3-2 Open Correction

3. Open the test terminals.
4. Press **ENTER** key to start open correction measurement.
5. Press other keys to cancel correction operation and exit to measurement status.
6. TH2811D automatically scans all the ranges at all frequencies to perform open correction measurement, and the current correction frequency and range number are displayed at the bottom of LCD.
7. If the current correction result is correct, "**PASS**" will be displayed in the secondary parameter display area. Then TH2811D continues performing correction to the next frequency point or range.
8. If the current correction result is not correct, "**FAIL**" will be displayed in the secondary parameter display area, and the instrument automatically exits from correction operation to measurement status.
9. The instrument will return to the measurement status after the open correction successfully completes.

3.10 Short Correction

1. Press **SHORT** key to select short correction function.
2. The information shown in Figure 3-3 will be displayed. **SHORT** flashes.

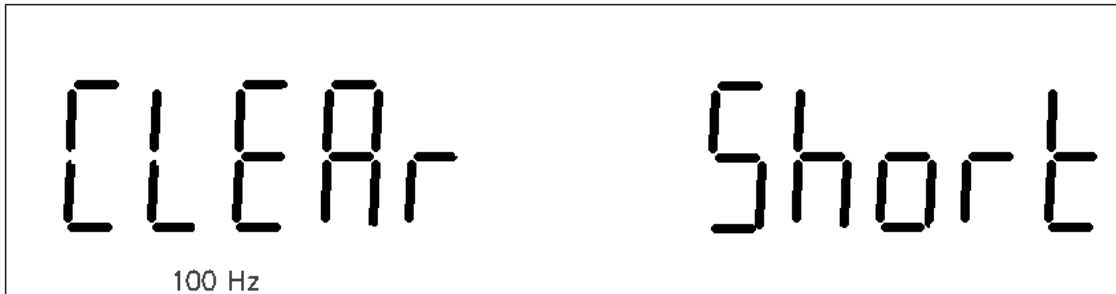

Figure 3-3 Short Correction

3. Short the test terminals using low-impedance shorting plate.
4. Press **ENTER** key to start short correction measurement.
5. Press other keys to cancel correction operation and exit to measurement status.
6. TH2811D automatically scans all the ranges at all frequencies to perform short correction measurement, and the current correction frequency and range number are displayed at the bottom of LCD.
7. If the current correction result is correct, **PASS** will be displayed in the secondary parameter display area. Then TH2811D continues performing correction to the next frequency point or range.
8. If the current correction result is not correct, **FAIL** will be displayed in the secondary parameter display area, and the instrument automatically exits from correction operation to measurement status.
9. The instrument will return to the measurement status after the short correction successfully completes.

Notice:

- Please perform the OPEN and SHORT correction again, when the test conditions are changed, such as test fixture, environment, including temperature and humidity.
- If **FAIL** is occasionally displayed during the short correction measurement, this is probably because the fixture contacts are not shorted with the low-impedance shorting plate, or the fixture is not shorted reliably. Please short the fixture carefully and perform the short correction again.
- Correction data under different test level, frequency and output impedance are stored separately in the non-volatile memory. So it is not necessary to perform correction again under the same test conditions.

Chapter 4 Specifications

The complete TH2811D specifications are listed below. These specifications are the performance standards. When shipped from the factory, the TH2811D meets the specifications listed in this section.

4.1 Measurement Parameters

1. Primary measurement parameters:
 - L: inductance
 - C: capacitance
 - R: resistance
 - Z: impedance
2. Secondary measurement parameters
 - D: dissipation
 - Q: quality factor
3. Combinations of measurement parameters
 - L-Q
 - C-D
 - R-Q
 - Z-Q

4.2 Equivalent Measurement Circuit Mode

- SER: Series equivalent circuit
- PAR: Parallel equivalent circuit

The actual capacitor, resistor and inductor are not the ideal capacitor, resistor and inductor. Normally, a component has the characteristics of the resistor and the reactor at the same time. The actual component is composed of an ideal resistor and a reactor (ideal inductor or capacitor) in series or parallel equivalent circuits.

The value in the two different equivalent circuits can be converted to each other using the following formulas in Table 4-1. The values of L and C in two different equivalent circuits are different due to the quality factor Q (or the dissipation factor D). But D and Q always have the same value in both equivalent circuit modes.

Table 4-1 Equivalent Circuit Transform

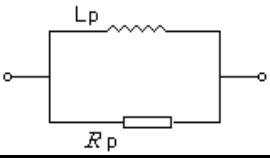
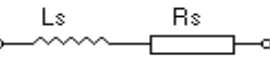
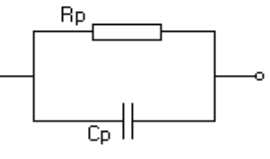
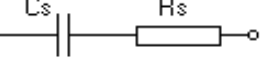
Circuit Mode		Dissipation Factor	Transform
L		$D=2\pi f L_p/R_p=1/Q$	$L_s=L_p/(1+D^2)$ $R_s=R_p D^2/(1+D^2)$
		$D=R_s/2\pi f L_s=1/Q$	$L_p=(1+D^2)L_s$ $R_p=(1+D^2)R_s/D^2$
C		$D=1/2\pi f C_p R_p=1/Q$	$C_s=(1+D^2)C_p$ $R_s=R_p D^2/(1+D^2)$
		$D=2\pi f C_s R_s=1/Q$	$C_p=C_s/(1+D^2)$ $R_p=R_s(1+D^2)/D^2$

Q, D and Xs are defined as follows

$$Q=X_s/R_s$$

$$D=R_s/X_s$$

$$X_s=1/2\pi f C_s=2\pi f L_s$$

Where, Suffix s means series circuit mode, and suffix p means parallel circuit mode.

Generally, for low impedance component (such as large capacitor or small inductor), the series equivalent circuit mode should be used. While for high impedance component (such as small capacitor or large inductor), the parallel equivalent circuit mode is the appropriate choice. We also select the equivalent circuit mode according to the actual usage in different circuits. If a capacitor is used as a filter capacitor, series circuit mode is the best choice. If a capacitor is used in a LC oscillator, then the parallel circuit mode should be selected.

4.3 Measurement Range

When TH2811D is operated under 100Ω signal resistance, 5 ranges are available: 30Ω, 100Ω, 1kΩ, 10kΩ and 100kΩ. When it is operated under 30Ω signal resistance, 6 ranges are available: 10Ω, 30Ω, 100Ω, 1kΩ, 10kΩ and 100kΩ.

AUTO or HOLD mode can be selected for measurement range operation.

4.4 Measurement Terminals

4 measurement Terminals:

H_{CUR}: high current

H_{POT}: high potential

L_{POT}: low potential

L_{CUR}: low current

4.5 Measurement Speed

TH2811D's measurement speed is affected by measurement frequency, integration time, component value, display mode, range mode and comparator on/off etc. Three kinds of measurement speeds can be selected by user: FAST, MED and SLOW. Generally, slower measurement speed will result in more stable and accurate measurement results.

FAST Speed: 10meas/sec
 MED Speed: 4.0meas/sec
 SLOW Speed: 2.5meas/sec

4.6 Basic Accuracy

C: $0.1\% (1 + C_x/C_{max} + C_{min}/C_x)(1 + D_x)(1 + k_s + k_v + k_f)$;
 L: $0.1\% (1 + L_x/L_{max} + L_{min}/L_x)(1 + 1/Q_x)(1 + k_s + k_v + k_f)$;
 Z: $0.1\% (1 + Z_x/Z_{max} + Z_{min}/Z_x)(1 + k_s + k_v + k_f)$;
 R: $0.1\%(1 + R_x/R_{max} + R_{min}/R_x)(1 + Q_x)(1 + k_s + k_v + k_f)$;
 D: $\pm 0.0010(1 + Z_x/Z_{max} + Z_{min}/Z_x)(1 + D_x + D_x^2)(1 + k_s + k_v + k_f)$;
 Q: $\pm 0.0015(1 + Z_x/Z_{max} + Z_{min}/Z_x)(Q_x + 1/Q_x)(1 + k_s + k_v + k_f)$;

Where,

1. D, Q is the absolute deviation, and the rest are the percent deviations, $D_x=1/Q_x$;
2. Parameters with suffix "x" are measured results. Parameters with suffix "max" are the maximum values listed in Table 4-2. Parameters with suffix "min" are the minimum values listed in Table 4-2.
3. k_s is the speed factor, k_v is the voltage level factor, k_f is the frequency factor.
4. When calibration measurement is performed, reliable open and short corrections should be performed for better measurement accuracy.

4.6.1 Maximum and Minimum Values of Measurement Parameters Affecting Accuracy

Table 4-2 Maximum and minimum values

Parameter	Frequency			
	100Hz	120Hz	1kHz	10kHz
Cmax	800 μ F	667 μ F	80 μ F	8 μ F
Cmin	1500pF	1250pF	150pF	15pF
Lmax	1590H	1325H	159H	15.9H
Lmin	3.2mH	2.6mH	0.32mH	0.032mH
Zmax	1M Ω			
Zmin	1.59 Ω			

4.6.2 Measurement Speed Factor ks

Slow: ks=0;
Medium: ks=0;
Fast: ks=10.

4.6.3 Measurement Voltage Level Factor kv

1.0Vrms: kv=0;
0.3Vrms: kv=1.

4.6.4 Measurement Frequency Factor kf

100Hz: kf=0;
120Hz: kf=0;
1kHz: kf=0;
10kHz: kf=0.5.

4.7 Measurement Frequency

TH2811D provides 4 kinds of test frequencies: 100Hz, 120Hz, 1kHz and 10kHz.
Accuracy: $\pm 0.02\%$

4.8 Test Signal Level

0.3 Vrms $\pm 10\%$
1.0 Vrms $\pm 10\%$

4.9 Output Impedance

30 $\Omega \pm 5\%$
100 $\Omega \pm 5\%$

4.10 Display Range

Parameter	Frequency	Measurement range
L	100Hz、120Hz	1 μ H to 99999H
	1kHz	0.1 μ H to 99999H
	10kHz	0.01 μ H to 99999H
C	100Hz、120Hz	1pF to 99999 μ F
	1kHz	0.1pF to 99999 μ F
	10kHz	0.01pF to 99999 μ F
	R,Z	0.1m Ω to 99.9M Ω
	Q	0.0001 to 99999
	D	0.0001 to 9.9999

4.11 Correction Function

Open Correction

Open correction eliminates the effect of stray admittance (G, B) in parallel with the component under test, such as stray capacitance.

Short Correction

Short correction eliminates the effect of the rest impedance in series with the component under test, such as lead resistance or lead inductance.

4.12 Range Mode

AUTO:

TH2811D automatically selects the appropriate range according to the DUT's impedance.

HOLD:

The measurement range is fixed at the current setting.