OPERATION MANUAL

TH2810D LCR Meter

<u>CHAPTER 1 PREPARATION.....</u>	<u>1-8</u>
1.1 UNPACKING AND INSPECTION.....	1-8
1.2 POWER REQUIREMENTS	1-8
1.3 LINE VOLTAGE AND FUSE SELECTION	1-8
1.4 OPERATION ENVIRONMENT	1-9
1.5 USE TEST FIXTURE	1-9
1.6 WARM-UP AND CONTINUOUS WORKING TIME.....	1-10
1.7 OTHER FEATURES	1-10
<u>CHAPTER 2 PANEL DESCRIPTION.....</u>	<u>2-11</u>
2.1 A TOUR OF THE FRONT PANEL.....	2-11
2.2 A TOUR OF THE REAR PANEL.....	2-13
2.3 DISPLAY AREA DEFINITION.....	2-14
<u>CHAPTER 3 OPERATION.....</u>	<u>3-17</u>
3.1 POWER ON	3-17
3.2 THE PRIMARY FUNCTION OPERATION	3-17
3.2.1 MEASUREMENT FUNCTION	3-17
3.2.2 TEST FREQUENCY.....	3-18
3.2.3 TEST SIGNAL LEVEL.....	3-19
3.2.4 PRIMARY PARAMETER DISPLAY MODE	3-19
3.2.5 MEASUREMENT SPEED.....	3-20
3.2.6 MEASUREMENT RANGE	3-20
3.3 THE SECONDARY FUNCTION OPERATION.....	3-23
3.3.1 CORRECTION.....	3-23
3.3.2 COMPARATOR FUNCTION.....	3-25
3.3.2.1 Comparator Function ON/OFF	3-25
3.3.2.2 Input the Low/High Limits.....	3-25
3.3.3 SIGNAL SOURCE OUTPUT IMPEDANCE	3-27
3.3.4 BEEP FUNCTION.....	3-28
3.3.5 MEASUREMENT MODE	3-28
3.3.6 EQUIVALENT CIRCUIT.....	3-29
3.3.6.1 Series and Parallel Circuit Setup.....	3-29
3.3.6.2 How to Select the Measurement Circuit Mode	3-29
3.3.7 RS232 SERIAL INTERFACE.....	3-30
<u>CHAPTER 4 HANDLER INTERFACE</u>	<u>4-31</u>
4.1 INTRODUCTION	4-31

4.2 OPERATION	4-31
4.2.1 SIGNAL DEFINITION	4-31
4.2.2 ELECTRICAL CHARACTERISTICS	4-36
CHAPTER 5 RS232C SERIAL INTERFACE	5-38
5.1 INTRODUCTION	5-38
5.2 TH2810D'S SERIAL INTERFACE	5-38
5.3 COMMUNICATION WITH A COMPUTER	5-39
5.4 SERIAL PORT PARAMETER	5-39
5.5 SOFTWARE PROTOCOL	5-39
CHAPTER 6 THE SPECIFICATIONS	41
6.1 MEASUREMENT FUNCTIONS	41
6.2 EQUIVALENT MEASUREMENT CIRCUIT	41
6.3 MEASUREMENT RANGE	42
6.4 TRIGGER MODE	43
6.5 MEASUREMENT TERMINALS	43
6.6 MEASUREMENT SPEED	43
6.7 BASIC ACCURACY	43
6.7.1 MAXIMUM AND MINIMUM VALUES USED FOR ACCURACY CALCULATION	44
6.7.2 MEASUREMENT SPEED FACTOR KS	44
6.7.3 MEASUREMENT VOLTAGE LEVEL FACTOR KV	44
6.7.4 MEASUREMENT FREQUENCY FACTOR KF	44
6.8 MEASUREMENT FREQUENCY	44
6.9 TEST SIGNAL LEVEL	45
6.10 OUTPUT IMPEDANCE	45
6.11 DISPLAY RANGE	45
6.12 CORRECTION FUNCTION	45
6.13 COMPARATOR FUNCTION	45
6.14 RANGING MODE	46
6.15 BEEP FUNCTION	46
6.16 RS232 INTERFACE	46
6.17 HANDLER INTERFACE	46
CHAPTER 7 COMMAND REFERENCE	47
7.1 INTRODUCTION	47

7.2 NOTATION CONVENTIONS AND DEFINITIONS	47
7.3 COMMAND STRUCTURE	47
7.4 COMMAND ABBREVIATIONS.....	49
7.5 HEADER AND PARAMETERS	49
7.6 COMMAND DESCRIPTION.....	50
7.6.1 SPEED COMMAND	50
7.6.2 DISPLAY COMMAND	50
7.6.3 FREQUENCY COMMAND	51
7.6.4 PARAMETER COMMAND.....	51
7.6.5 LEVEL COMMAND	52
7.6.6 SRESISTOR COMMAND.....	53
7.6.7 TRIGGER COMMAND	53
7.6.8 CORRECTION COMMAND.....	54
7.6.9 COMPARATOR COMMAND.....	54
7.6.10 EQUIVALENT COMMAND	55
7.6.11 RANGE COMMAND	55
7.6.12 ALARM COMMAND	56
7.6.13 LIMIT SUBSYSTEM.....	57
7.6.14 FETCH? QUERY	58

Manual Print History

The manual print history shown below lists all the printing dates and editions. The printing date changes when a new edition is released. The latest editions can be downloaded from our website.

March 2006 First Edition
December 2007 Second Edition

Warranty

This Tonghui instrument product is warranted against defects in material and workmanship for a period of two years from the date of shipment. Other items such as test fixtures, test cables are warranted for 90 days from the date of shipment. During the warranty period, we will, at our option, either repair or replace products which prove to be defective.

For warranty service or repair, this product must be returned to a service facility designated by Tonghui. Purchaser shall prepay shipping charges to Tonghui and Tonghui shall pay for the return of the product to Buyer. However, Buyer shall pay all shipping charges, duties, taxes, and any other charges for products returned to Tonghui from another country.

Limitation of Warranty

This warranty does not apply to defects resulting from improper or inadequate maintenance and care by Buyer, Buyer-supplied software or interfacing, unauthorized modification or misuse, operation outside of the environmental specifications for the product, or improper site preparation or maintenance.

No other warranty is expressed or implied. Tonghui specially disclaims the implied warranties of merchantability and fitness for a particular use.

Tonghui's responsibility to repair or replace defective products is the sole and exclusive remedy provided to the customer for breach of this warranty. Tonghui shall not be liable for any direct, indirect, special, incidental, or consequential damages, whether based on contract, tort, or any other legal theory.

Safety Precautions

The following safety precautions must be observed to avoid injury and prevent damage to this product or any products connected to it. To avoid potential hazards, read the operating information carefully before using the product and use this product only as specified.

NOTE: *This product complies with INSTALLATION CATEGORY I as well as POLLUTION DEGREE 2. This product is an INDOOR USE product.*

- Ground the Instrument

Before operating the instrument, make sure the instrument chassis is grounded with the 3-pole power cable.

- Don't operate in an explosive atmosphere

To prevent explosion or fire, don't operate the instrument in the presence of inflammable gases or fumes.

- Use the proper fuse

Replace the broken fuse with the same type and rating for continuous protection against fire hazard.

- Keep away from live circuits

Don't remove the instrument covers when operating the instrument. Component replacement and internal adjustment can only be done by qualified personnel. Don't replace components with the power cable connected. Dangerous voltage may remain even after the power cable has been disconnected. Always remove the power cable from the instrument and discharge circuits before touching them.

Chapter 1 Preparation

This chapter provides the information necessary for performing an incoming inspection and setting up the instrument before operation.

1.1 Unpacking and Inspection

Thank you for purchasing and using our product. Inspect the shipping container for damage. If the shipping container or cushioning material is damaged, it should be kept until the contents of the shipment have been checked for completeness and the TH2810D has been checked mechanically and electrically. The contents of the shipment should be as listed in the packing list. If the contents are incomplete, if there is mechanical damage or defect, if the instrument does not work normally, notify our company or our local representative.

Keep the shipping container and packing material for future use such as returning for re-calibration or service.

1.2 Power Requirements

- (1) Voltage: 198 to 242 Vac, or 99 to 121Vac
- (2) Frequency: 47.5 to 63 Hz
- (3) Power: 20 VA maximum
- (4) In accordance with internal safety standards, this instrument is equipped with a three-wire power cable. When connected to an appropriate ac power outlet, this cable grounds the instrument frame.
- (5) The instrument is carefully designed in order to reduce the disturbance induced by AC power supply, however, low noise environment is recommended. Sometimes a power source filter is needed.

Warning: For protection from electrical shock, the power cable ground must not be defeated. The power plug must be plugged into an outlet that provides a protective earth ground connection.

1.3 Line Voltage and Fuse Selection

Figure 1-1 illustrates the line voltage selection switch on the instrument's rear panel. Before connecting the instrument to the power source, make sure that the correct fuse has been installed and the Line Voltage Selection Switch is correctly set.



Figure 1-1 Line Voltage Selector

The instrument has been equipped with the 200 mA fuse before leaving factory. Use only fuses with the required current rating and of the specified type as replacements. Do not use a mended fuse or short-circuit the fuse-holder in order to by-pass a blown fuse. Find out what caused the fuse to blow!

1.4 Operation Environment

- (1) Please do not operate the instrument in places where there is dusty, vibrant, under direct sunlight, or where there is corrosive air.
- (2) In order to maintain good measurement accuracy, the TH2810D must be operated under the following environment conditions:
Temperature: 0°C ~ 40°C
Humidity: ≤ 75% RH at 40°C.
- (3) The instrument is carefully designed in order to reduce the disturbance induced by AC power supply, however, low noise environment is recommended. Sometimes a power source filter is needed.
- (4) Please store the instrument in the place where the temperature is between 5°C and 40°C, humidity is less than 85% RH. If the instrument will not be put in use for a time, please have it properly packed with its original box or a similar box for storage.
- (5) The instrument, especially the test leads, should be kept far away from strong electromagnetic field to avoid interference with measuring precision.

1.5 Use Test Fixture

Original test fixture and test clip leads should be used in order to ensure correct and accurate measuring results. At the same time, test fixture, test clip leads and pins of DUT should be kept clean in order to connect well between DUT and test fixture. Test fixture and test clip leads are connected to Hcur、Hpot、Lcur and Lpot 4 terminals on the front panel.

For DUT which has shield, please connect the shield to the ground terminal “⊥” of the instrument.

1.6 Warm-up and Continuous Working Time

Warm up the instrument for a minimum time of 15 minutes in order to ensure measuring precision.

Continuous working time should be less than 16 hours.

1.7 Other features

(1) Power consumption: $\leq 20\text{VA}$

(2) Dimension(W*H*D) : 350mm*110mm*340mm

(3) Weight: about 3.5kg

Chapter 2 Panel Description

This chapter provides information including a tour of the front and rear panel and display area definition, which will help you to quickly learn how to operate the TH2810D.

2.1 A Tour of the Front Panel

Figure 2-1 shows the brief description of each key on the TH2810D's front panel.

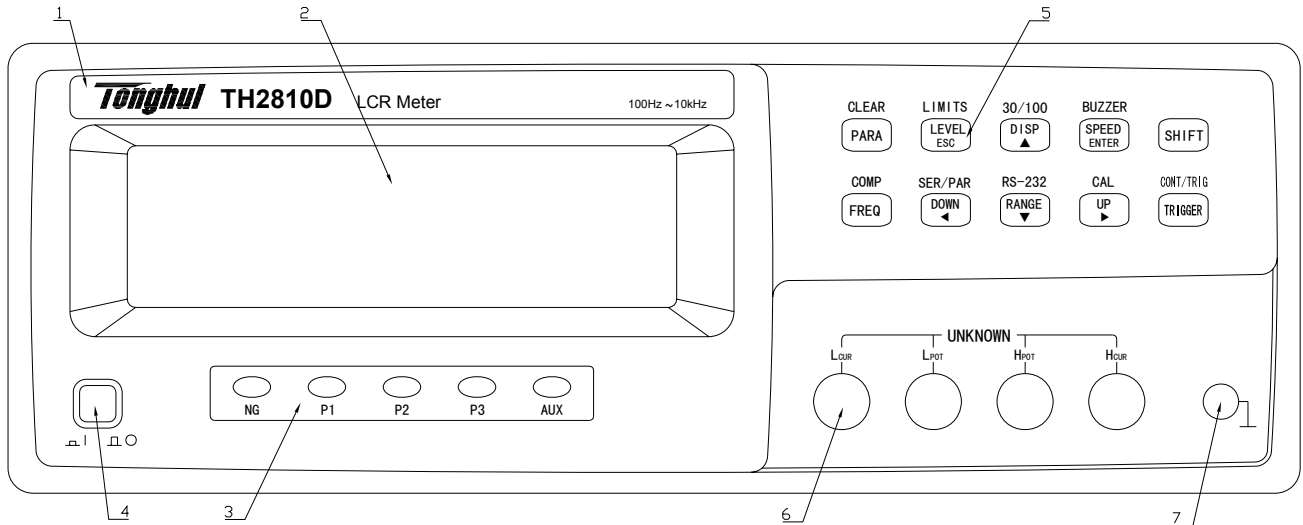

Figure 2-1 Front panel Overview

(1) Brand and Model

Mark and model of instrument

(2) LCD

Display the measurement results and test conditions, etc.

(3) Comparator Indication

Display the comparator sorting results: NG, P1, P2, P3, and AUX.

(4) Power on/off

Power on/off switch. In the "ON" position all operating voltages are applied to the instrument. In the "OFF" position NO operating voltages are applied to the instrument.

(5) Keys

a) **PARA** key:

The primary function is the setup key of test parameter.

The secondary function is the zero correction key **CLEAR**.

b) **FREQ** key:

The primary function is the setup key of test frequency.

The secondary function is the comparison function key **COMP**.

-
- c) **LEVEL** key:
The primary function is the setup key of test voltage level.
Under input status (“**ENTRY**” is lighted), it is the exit key **[ESC]**.
The secondary function is the sorting limits setup key **LIMITS**.
- d) **DISP** key:
The primary function is the setup key of main parameter display mode.
Under input status (“**ENTRY**” is lighted), it is the up cursor key or increase key **[▲]**.
The secondary function is signal source output impedance setup key **30/100**.
- e) **SPEED** key:
The primary function is the setup key of measurement speed.
Under input status (“**ENTRY**” is lighted), it is the **[ENTER]** key.
The second function is buzzer’s beep status setup key **BUZZER**.
- f) **SHIFT** key:
The secondary function enable key.
- g) **TRIGGER** key:
The primary function is the trigger key.
The secondary function is continuous and single measurement switch key **CONT/TRIG**.
- h) **DOWN** key:
The primary function is the measurement range selection key.
Under input status (“**ENTRY**” is lighted), it is the left cursor key **[◀]**.
The secondary function is the equivalent circuit setup key **SER/PAR**.
- i) **RANGE** key:
The primary function is the setup key of range HOLD or AUTO.
Under input status (“**ENTRY**” is lighted), it is the down cursor or decrease key **[▼]**.
The secondary function is the RS232 interface on/off key **RS232**.
- j) **UP** key:
The primary function is the measurement range selection key.
Under input status (“**ENTRY**” is lighted), it is the right cursor key **[▶]**.
The secondary function is the calibration function key **CAL**.

(6) UNKNOWN Terminals

There are 4 unknown terminals used to connect a 4-terminal test fixture or test leads for measuring the device under test.

H_{CUR}: High current

H_{POT}: High potential

L_{POT}: Low potential

L_{CUR}: Low current

(7) Frame Terminal

This is the frame terminal which is tied to the instrument's chassis and which can be used for measurements that require guarding.

2.2 A Tour of the Rear Panel

Figure 2-2 shows a brief description of the TH2810D's rear panel.

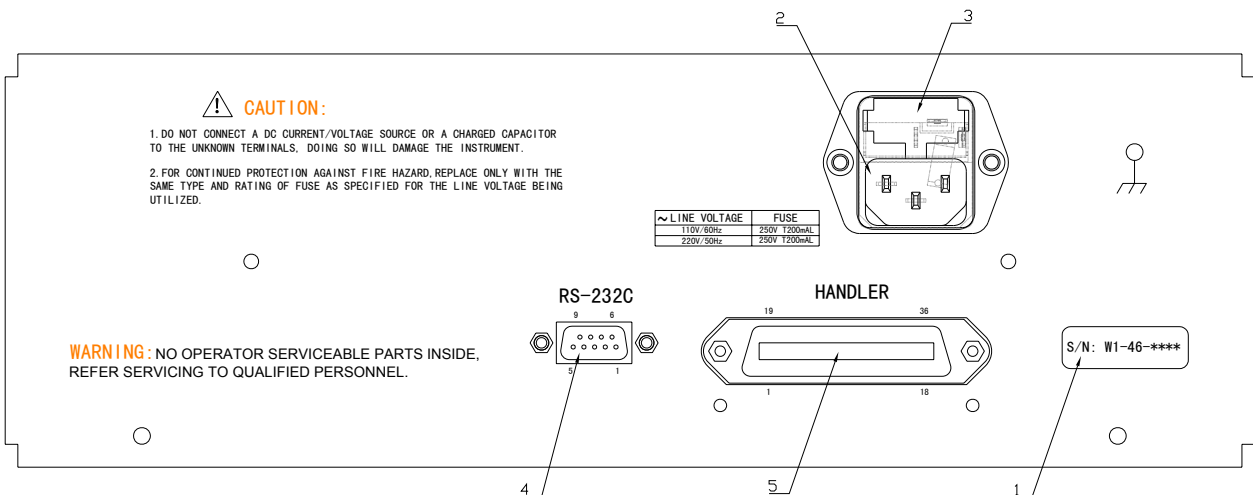

Figure 2-2 Rear panel Overview

(1) Name Plate

Name plate is used to provide the information of date, model, lot number and manufacturer etc.

(2) Line Input Receptacle

AC power cord receptacle.

(3) Fuse Holder and Line Voltage Selector

Fuse holder and Line voltage selector for TH2810D line input.

(4) RS232C Interface

This is the RS232C interface connector used when operating through the serial interface.

(5) Handler Interface

This is the HANDLER interface connector used when operating with a component handler to fully automate component testing, sorting, and quality control data processing. TH2810D receives the Trigger signal and outputs the comparison results through the HANDLER interface.

2.3 Display Area Definition

Figure 2-3 shows the display area definition of the TH2810D LCD screen.

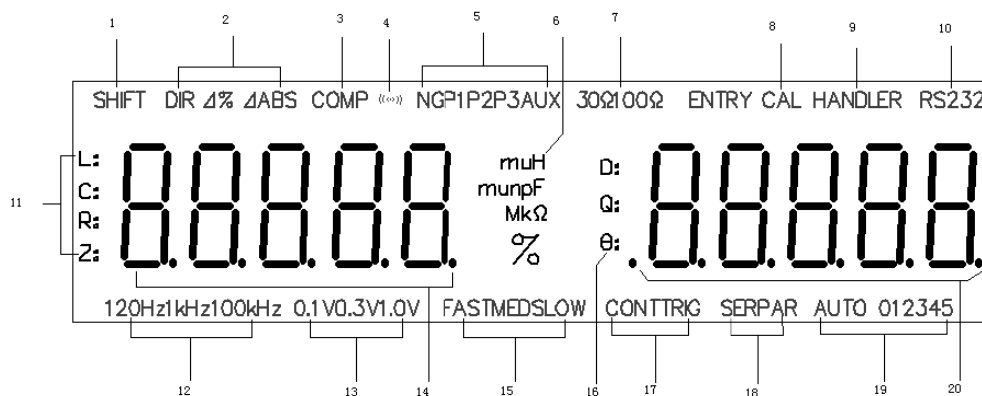

Figure 2-3 Display Area Definition

(1) The Secondary Function Indication

“**SHIFT**” is on: The current key function is the secondary function.

“**SHIFT**” is off: The current key function is the primary function.

(2) Display Mode of The Primary Parameter Indication

Indicate the current primary parameter display mode.

“**DIR**” is on: Direct reading display mode.

“**Δ%**” is on: Percent deviation display mode.

“**ΔABS**” is on: Absolute deviation display mode.

(3) Comparator Function Indication

“**COMP**” is on: The comparator function is turned on.

“**COMP**” is off: The comparator function is turned off.

(4) Alarm Indication

“(⊙)” is on: Alarm buzzer is turned on.

“(⊙)” is off: Alarm buzzer is turned off.

(5) Comparison Results Indication

“**NG**” is on: No good bin

“**P1**” is on: Bin 1.

“**P2**” is on: Bin 2.

“**P3**” is on: Bin 3.

“**AUX**” is on: Auxiliary bin.

(6) Unit of The primary Parameter Indication

Indicate the current unit of measurement result of the primary parameter.

Unit of inductance: μH , mH , H .

Unit of capacitance: pF , nF , μF , mF .

Unit of resistance/impedance: Ω , $\text{k}\Omega$, $\text{M}\Omega$.

(7) Signal Source Output Impedance Indication

“**30 Ω** ” is on: Signal source output impedance is 30 Ω .

“**100 Ω** ” is on: Signal source output impedance is 100 Ω .

(8) Calibration Measurement Indication

“**CAL**” is on: The instrument is under calibration measuring status.

“**CAL**” is off: The instrument is under normal measuring status.

(9) Handler Interface indication

“**Handler**” is on: Handler interface is on, signal output is enabled.

“**Handler**” is off: Handler interface is off, signal output is disabled.

(10) RS232 Interface Indication

“**RS232**” is on: RS232 interface is enabled.

“**RS232**” is off: RS232 interface is disabled.

(11) The primary Parameter Indication

Indicate the current measuring primary parameter user selected.

“**L:**” is on: Inductance is measured and displayed.

“**C:**” is on: Capacitance is measured and displayed.

“**R:**” is on: Resistance is measured and displayed.

“**Z:**” is on: Impedance is measured and displayed.

(12) Test Signal Frequency Indication

“**100 Hz**” is on: The current test signal frequency is 100 Hz.

“**120 Hz**” is on: The current test signal frequency is 120 Hz.

“**1 kHz**” is on: The current test signal frequency is 1 kHz.

“**10 kHz**” is on: The current test signal frequency is 10 kHz.

(13) Test Signal Level Indication

“**0.1 V**” is on: The current test signal voltage is 0.1 V.

“**0.3 V**” is on: The current test signal voltage is 0.3 V.

“**1.0 V**” is on: The current test signal voltage is 1.0 V.

(14) The Primary Parameter Display

Display the current measurement result of the primary parameter.

(15) Measurement Speed Indication

“**FAST**” is on: Fast measurement speed

“**MED**” is on: Medium measurement speed

“**SLOW**” is on: Slow measurement speed

(16) The Secondary Parameter Indication

Indicate the current measuring secondary parameter user selected.

(17) Measurement Mode Indication

“**CONT**” is on: Continuous measurement mode

“**TRIG**” is on: Single measurement mode

(18) Equivalent Circuit Mode Indication

“**SER**” is on: Series equivalent circuit mode.

“**PAR**” is on: Parallel equivalent circuit mode.

(19) Range Indication

Indicate the current ranging mode and the current range number.

“**AUTO**” is on: Range AUTO

“**AUTO**” is off: Range HOLD

(20) The Secondary Parameter Display

Display the current measurement result of the secondary parameter.

Chapter 3 Operation

3.1 Power On

- 1) Press power switch to turn on the instrument.
- 2) Version number of the instrument is first displayed on the LCD screen.
- 3) The instrument enters the measurement status after a short delay. Figure 3.1 shows the information displayed in measurement status. It may be different with the actual display due to different measurement setup.

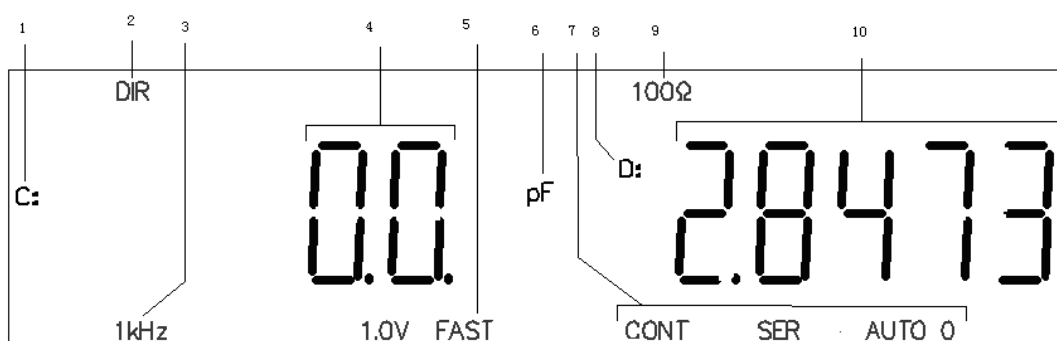

Figure 3.1 LCD Display in Measurement Status

Description of Measuring LCD Display:

- ① Primary parameter: C
- ② Display mode: DIR
- ③ Measuring frequency: 1 kHz
- ④ Primary parameter measurement result display
- ⑤ Measurement speed: FAST
- ⑥ Primary parameter unit: pF
- ⑦ Continuous, serial equivalent circuit and range AUTO (0)
- ⑧ Secondary parameter: D (dissipation factor)
- ⑨ Signal source output impedance: 100Ω
- ⑩ Secondary parameter measurement result display

3.2 The Primary Function Operation

3.2.1 Measurement Function

TH2810D measures two components of the complex impedance parameters at the same time in a measurement cycle. The primary and secondary measurement parameters are listed as follows.

■ Primary Parameter

- L: Inductance
- C: Capacitance
- R: Resistance
- |Z|: Absolute value of impedance

- **Secondary Parameter**

D: Dissipation factor

Q: Quality factor

$|Z|$ is the absolute value of impedance, so it is always a positive value; While L/ C/ R maybe a positive value or sometimes a negative value.

When measurement function is C-D and the primary parameter measurement result is negative, this means the component under test is probably an inductor.

When measurement function is L-Q and the primary parameter measurement result is negative, this means the component under test is probably a capacitor.

When measurement function is R-Q and the measurement result of resistor is negative, this is due to over zero correction, please perform open and short correction correctly.

TH2810D provides 4 combinations of primary and secondary parameters:

- L-Q
- C-D
- R-Q
- Z-Q

Perform the following steps to set the measurement function.

1. Assume that current measurement function is L-Q. Primary parameter indication is “L:”, secondary parameter indication is “Q:”.
2. Press **PARA** key, measurement function is changed to C-D. Primary parameter indication is “C:”, secondary parameter indication is “D:”.
3. Press **PARA** key, measurement function is changed to R-Q. Primary parameter indication is “R:”, secondary parameter indication is “Q:”.
4. Press **PARA** key, measurement function is changed to Z-Q. Primary parameter indication is “Z:”, secondary parameter indication is “Q:”.
5. Keep on pressing **PARA** key, until the measurement function required is indicated.

3.2.2 Test Frequency

TH2810D provides 4 typical frequency points: 100 Hz, 120 Hz, 1 kHz and 10 kHz. The current test frequency is displayed on the bottom area of LCD.

Perform the following steps to set the test frequency.

1. Assume the current test frequency of the instrument is 100Hz. “100Hz” is indicated on the bottom of LCD.
2. Press **FREQ** key, test frequency is changed to 120 Hz, and “120Hz” is indicated on the bottom of LCD.
3. Press **FREQ** key, test frequency is changed to 1 kHz, and “1kHz” is indicated on the bottom of LCD.
4. Press **FREQ** key, test frequency is changed to 10 kHz, and “10kHz” is indicated on the bottom of LCD.

-
5. Press **FREQ** key, test frequency is changed back to 100Hz, and “**100Hz**” is indicated on the bottom of LCD.
 6. Keep on pressing **FREQ** key, until the test frequency required is indicated on the bottom of LCD.

3.2.3 Test Signal Level

TH2810D provides 3 kinds of test signal voltage levels: 0.1V_{RMS}, 0.3 V_{RMS} and 1.0 V_{RMS}.

Perform the following steps to set the test signal level.

1. Assume the current test signal level 1.0V, and “**1.0V**” indicated on the bottom of LCD.
2. Press **LEVEL** key, test signal level is changed to 0.1V, and “**0.1V**” is indicated on the bottom of LCD.
3. Press **LEVEL** key, test signal level is changed to 0.3V, and “**0.3V**” is indicated on the bottom of LCD.
4. Press **LEVEL** key, test signal level is changed back to 1.0V, and “**1.0V**” is indicated on the bottom of LCD.
5. Keep on pressing **LEVEL** key, until the test signal level required is indicated on the bottom of LCD.

3.2.4 Primary Parameter Display Mode

TH2810D provides three kinds of display modes for the primary parameter:

- DIR:** Direct reading display mode
- ΔABS:** Absolute deviation display mode
- Δ%:** Percent deviation display mode

■ ΔABS deviation display mode:

The difference between the measured value of the DUT and a previously stored reference value are displayed. The formula used to calculate the deviation is as follows.

$$\Delta\text{ABS} = X - Y$$

Where, X: The measured value of DUT
Y: The stored reference value

■ Δ% deviation display mode:

The difference between the measured value of the DUT and a previously stored reference value are displayed as a percentage of the reference value. The formula used to calculate the percent deviation is as follows.

$$\Delta\% = (X - Y) / Y \times 100 [\%]$$

Where, X: The measured value of the DUT
Y: The stored reference value

Perform the following steps to set the primary parameter display mode.

1. Assume the current display mode of the primary parameter is DIR, and “**DIR**” is indicated on the top of LCD.
2. Press **DISP** key, the display mode is changed to Δ ABS mode, and “ Δ **ABS**” is indicated on the top of LCD.
3. Press **DISP** key, the display mode is changed to Δ % mode, and “ Δ %” is indicated on the top of LCD.
4. Press **DISP** key, the display mode is changed back to DIR mode again, and “**DIR**” is indicated on the top of LCD.
5. Keep on pressing **DISP** key, until the display mode required is indicated on the top of LCD

3.2.5 Measurement Speed

TH2810D provides 3 kinds of measurement speeds: FAST, MED and SLOW. Generally, a slow measurement speed will result in more stable and accurate measurement results.

- FAST: 10 meas/sec
- MED: 4.0 meas/sec
- SLOW: 2.5 meas/sec

Perform the following steps to set the measurement speed

1. Assume the current measurement speed is FAST, and “**FAST**” is indicated on the bottom of LCD.
2. Press **SPEED** key, the measurement speed is changed to MED, and “**MED**” is indicated on the bottom LCD.
3. Press **SPEED** key, the measurement speed is changed to SLOW, and “**SLOW**” is indicated on the bottom of LCD.
4. Press **SPEED** key, the measurement speed is changed back to FAST, and “**FAST**” is indicated on the bottom of LCD.
5. Keep on pressing **SPEED** key, until the measurement speed required is indicated on the bottom of LCD.

3.2.6 Measurement Range

When signal source output impedance is 100 Ω , TH2810D provides 5 measurement ranges: 30 Ω , 100 Ω , 1k Ω , 10k Ω and 100k Ω . Table 3-1 shows the effective measuring range for each measurement range.

When signal source output impedance is 30 Ω , TH2810D provides 6 measurement ranges: 10 Ω , 30 Ω , 100 Ω , 1 k Ω , 10 k Ω and 100 k Ω . Table 3-2 shows the effective measuring range for each measurement range.

When the measurement range is set manually, the optimum measurement range should be selected by matching the DUT's impedance to the effective measuring range shown in Table 3-1 and Table 3-2. When the measurement range is set to AUTO, the optimum measurement range is automatically selected according to the impedance of each DUT, regardless of what kind of component is measured, a capacitor, a resistor or an inductor.

Table 3-1 Effective Measuring Range for Each Range

No.	Range Resistor	Effective Measuring Range
0	100 kΩ	100kΩ-100MΩ
1	10 kΩ	10kΩ-100kΩ
2	1 kΩ	1kΩ-10kΩ
3	100Ω	50Ω-1kΩ
4	30Ω	0Ω-50Ω

Under 100Ω Output Impedance

Table 3-2 Effective Measuring Range for Each Range Under 10Ω Output Impedance

No.	Range Resistor	Effective Measuring Range
0	100 kΩ	100kΩ-100MΩ
1	10 kΩ	10kΩ-100kΩ
2	1 kΩ	1kΩ-10kΩ
3	100Ω	100Ω-1kΩ
4	30Ω	15Ω-100Ω
5	10Ω	0Ω-15Ω

Perform the following steps to set the measurement range

1. Assume the current measurement range is set to "AUTO" status, and "AUTO n" is displayed on the bottom of LCD, here "n" is the current autoamttically selected range number.
2. Press **RANGE** key to change the measurement range from the "AUTO" mode to the "HOLD" mode. When the measurement range is set to the "HOLD" mode, "AUTO" is turned off from the LCD, the impedance range is fixed at the current range setting, and the current range number is indicated on the bottom of LCD.
3. Press **RANGE** key again to change the measurement range from the "HOLD" mode to the "AUTO" mode. "AUTO n" is displayed on the bottom of LCD, here "n" is the current auto selected range number.
4. Press [**◀**] or [**▶**] key to select the measurement range manually. If the current measurement range is in the "AUTO" mode, then measurement range mode will be changed to "HOLD" mode automatically. The current fixed range number is displayed on the bottom of LCD at the same time.

Notice:

In measurement range “HOLD” mode, if the measured impedance is out of the effective measuring range or display range of the current fixed range, “-----” will be displayed instead of the measurement results.

An example of how to calculate the optimum measurement range.

For a capacitor DUT, if $C=210\text{nF}$, $D=0.0010$, and measurement frequency $f=1\text{ kHz}$.

We can calculate the impedance of the capacitor as follows.

$$Z_x = R_x + \frac{1}{j2\pi f C_x}$$
$$|Z_x| \approx \frac{1}{2\pi f C_x} = \frac{1}{2 \times 3.1416 \times 1000 \times 210 \times 10^{-9}} \approx 757.9\Omega$$

According to above Table 3-1 or Table 3-2, we can find that the optimum measurement range is range 3.

3.3 The Secondary Function Operation

3.3.1 Correction

TH2810D's OPEN correction capability cancels errors due to the stray admittance (G, B) in parallel with the device under. TH2810D's SHORT correction capability corrects for the residual impedance (R, X) in serial with the device under test.

Perform following steps for the open and short correction:

1. When the TH2810D is under the measurement status, press **SHIFT** key. "**SHIFT**" will be lighted on the top left corner of LCD.
2. Press **CLEAR** key to enter the correction function.
3. If the fixture is open, the information shown in Figure 3-2 will be displayed. "**ENTRY**" is lighted, which means the instrument is under the input status. Input key functions of **[ESC]**, **[ENTER]**, **[◀]**, **[▶]**, **[▼]**, **[▲]** are enabled.

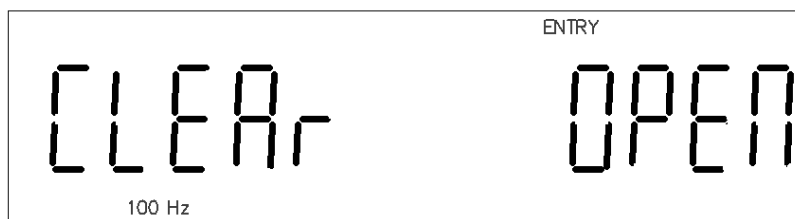

Figure 3-2 Open Correction

4. Press **[ESC]** key to cancel correction and return to the measurement status.
5. Press **[ENTER]** key to start open correction measurement.
6. The OPEN correction is performed at all frequency points and ranges. The current frequency and range being corrected are displayed on the bottom of LCD.
7. TH2810D judges the results of correction measurement automatically. If the current correction result is not correct, TH2810D will interrupt the current correction operation and return to the measurement status.
8. If the current correction result is correct, "**PASS**" will be displayed on the secondary parameter display area. Then TH2810D continues correction with the following frequency points and ranges.
9. The instrument will return to the display status of step 3 after the open correction is successfully completed.
10. Press **[ESC]** key to cancel correction and return to the measurement status.
11. If short correction is to be performed, short the measurement contacts of the fixture together with a low impedance shorting plate. The information shown in Figure 3-3 will be displayed.

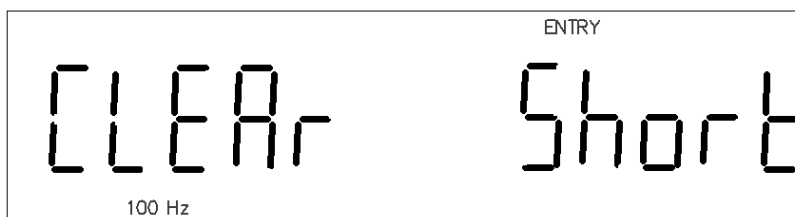

Figure 3-3 Short Correction

12. Press **[ENTER]** key to start short correction measurement.
13. The SHORT correction is performed at all frequency points and ranges. The current frequency and range being corrected are displayed on the bottom of LCD.
14. TH2810D judges the results of correction measurement automatically. If the current correction result is not correct, TH2810D will interrupt the current correction operation and return to the measurement status.
15. If the current correction result is correct, “**PASS**” will be displayed on the secondary parameter display area. Then TH2810D continues correction with the following frequency points and ranges.
16. The instrument will return to the display status of step 11 after the short correction is successfully completed.
17. Press **[ESC]** key to cancel correction function and return to the measurement status.
18. If a DUT is connected to the test fixture, or the fixture is not opened or shorted reliably, the instrument will not perform open or short operation. The information shown in figure 3-4 will be displayed. Press **[ESC]** key or **[ENTER]** key to return to the measurement status.

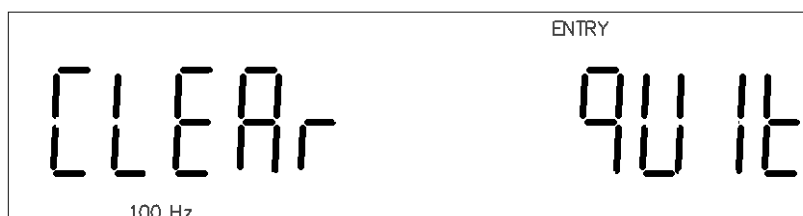

Figure 3-4 Exit Correction

Notice:

- Please perform the OPEN and SHORT correction again, when one of the following test conditions is changed.
 - ✧ Test fixture
 - ✧ Environment temperature and humidity
 - ✧ Signal source output impedance
 - ✧ Test signal voltage level
- If you press **[ESC]** key to interrupt the current correction process and return to the measurement status. The origin correction data will not be change.
- If “**FAIL**” is displayed during the short correction measurement. This is probably because the fixture contacts are not shorted with the low impedance shorting plate, or the fixture is not shorted reliably. Just short the fixture carefully and perform the short correction again.

-
- Correction data under different test level, frequency and output impedance are stored separately in the non-volatile memory. It is not necessary to correction again under the same test conditions.
 - TH2810D selects the OPEN or SHORT correction operation according to the current measured impedance automatically. If there is a component in the test fixture or if the fixture is not shorted or opened reliably, “QUIT” will be displayed in the second parameter display area.

3.3.2 Comparator Function

TH2810D’s built-in comparator can sort devices into a maximum of 4 bins (P1, P2, P3 and NG) using a maximum of three pairs of primary limits and one pair of secondary parameter limits. Also, a device whose primary parameter is within limits, but whose secondary parameter measurement result is not within limits can be sorted into an AUXiliary bin. The comparator function is especially useful when using the TH2810D with a component handler.

3.3.2.1 Comparator Function ON/OFF

Perform the following steps to set the comparator function to ON or OFF

1. Assume the instrument’s comparator function is OFF. “COMP” will not be displayed on the top of LCD, and sorting results will not be displayed on the top of LCD or indicated by the LEDs on the front panel.
2. Make sure that the instrument is under measurement status. Press **SHIFT** key, and “**SHIFT**” will be displayed on the top left corner of LCD.
3. Press **COMP** key, and “COMP” will be displayed on the top of LCD. This means comparator function is turned ON. Sorting results will be displayed on the top of LCD and indicated by LEDs on the front panel at the same time.
4. Repeat step 2 and 3. “COMP” will not be displayed on the top of LCD. That means comparator function is turned off.

3.3.2.2 Input the Low/High Limits

Three pairs of primary parameter limits, one pair of secondary parameter limits and nominal values for L, C, R, and Z can be inputted. Do not enter a value which is lower than the LOW limit in the tolerance sorting mode. If you do, the TH2810D will never sort a device into the Bin you specified. The key functions under limits input (“**ENTRY**” is lighted) status are described in table 3-3.

Table 3-3 The key functions under limits input status

Key	Main Menu	Data Input Status
[◀]	Select the previous limit	Move to the left digit
[▶]	Select the next limit	Move to the right digit
[▲]	Select the main parameter of the nominal to be inputted.	Add 1 to the current digit/Move the decimal or unit right.
[▼]	Select the main parameter of the nominal to be inputted.	Minus 1 from the current digit/Move the decimal or unit left.
[ENTER]	Enter the limit data input status.	Save the current limit inputted and return to the main menu.
[ESC]	Return to the measurement status	Return to main menu without changing the current limit value.

Perform the following steps to set the high/low limits:

1. Press **[SHIFT]** key to enable the secondary function. “**SHIFT**” will be displayed on the top left corner of LCD.
2. Press **[LIMITS]** key, the limit parameter and its value will be displayed as shown in figure 3-5. “**P1_**” is flashing, which means that it is now in the main menu. The previous low limit value of bin 1 is displayed in the main parameter display area.

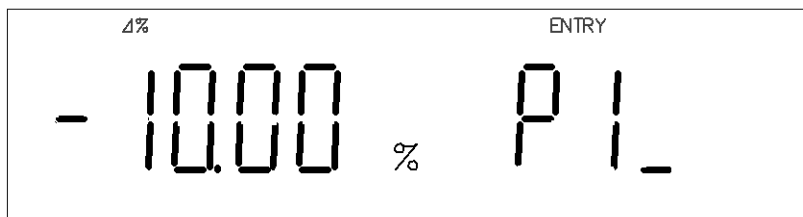

Figure 3-5 Low/high limits setup

3. If no change is required with the previous limit value, press [◀] or [▶] key to select another limit you want to modify. Press [ENTER] key to enter the data input status, the first left digit of the limit value will be flashing in the primary parameter display area.
4. Press [▲] or [▼] key to input 0, 1, 2, 3, 4, 5, 6, 7, 8 and 9. If the current flashing digit is the first left digit, “-” can also be inputted.
5. Press [◀] or [▶] key to select the other digit or decimal to be modified. The selected digit or decimal will be flashing.
6. Press [ESC] key to return to the main menu without changing the previous value of the limits.
7. Press [ENTER] key to save the current input limit value and return to the main menu.
8. Press [▶] key, “**P1⁻**” will be flashing in the secondary parameter display area, and the current high limit of bin 1 will be displayed in the primary parameter display area.
9. Repeat step 3 to 7 to input **P1⁻**, **P2⁻**, **P2⁻**, **P3⁻**, **P3⁻**, **Q⁻** and **D⁻** respectively. The low/high limits of P1, P2, and P3 are inputted as the percent tolerance values (the ratio

in percent), while the limits of Q_- and D^- are inputted as the absolute tolerance values (parameter value) .

10. Press [▶] key, until “STD” is flashing in the second parameter display area, and the current nominal value will be displayed in the primary parameter display area as shown in figure 3-6.

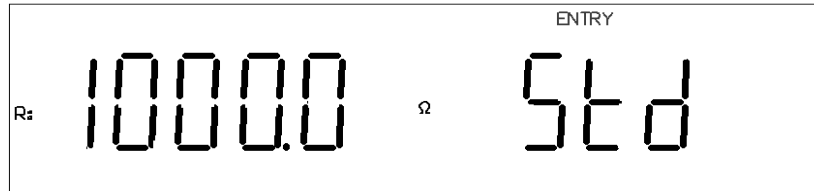

Figure 3-6 Nominal value setup

11. Press [▲] or [▼] key to select which nominal value will be inputted: L, C, R or Z. Nominal values of L, C, R and Z are stored respectively in different memory addresses.
12. If no change is required with the current nominal value, press [◀] or [▶] key to input other high/low limits. Press [ENTER] key to enter the data input status, the first left digit of the nominal value displayed in the primary display area will be flashing.
13. Press [▲] or [▼] key to input 0, 1, 2, 3, 4, 5, 6, 7, 8 and 9. If the current flashing digit is the first left digit, “-” can also be inputted.
14. Press [◀] or [▶] key to select the digit, decimal or unit to be modified. The selected digit, decimal or unit will be flashing.
15. Press [ESC] key to return to the main menu without changing the previous nominal value.
16. Press [ENTER] key to save the current input nominal value, and return to the main menu.
17. After all the sorting limits are inputted, press [ESC] key to return to the measurement status.

3.3.3 Signal Source Output Impedance

TH2810D provides two different signal output impedance 30Ω and 100Ω. The measurement current through the DUT will be different with different signal output impedance under the test same signal voltage level. The current sensitive components, for example the inductors with cores, will get different measurement results under different signal source output impedance. In order to be compatible with other well-known instruments in the world, use the same signal source output impedance for each instrument.

Perform the following steps to set the signal source output impedance

1. If “100Ω” is displayed on the top of LCD, this means the current signal source output impedance is 100Ω.
2. Press [SHIFT] key under the measurement status, and “SHIFT” on the top left corner of LCD is displayed.
3. Press [30/100] key to set the current source output impedance to 30Ω, and “30Ω” will be

displayed on the LCD.

- Repeat step 2 and 3, signal source output impedance will be switched between 30Ω and 100Ω.

3.3.4 Beep Function

TH2810D provides the beep alarm function under the specified sorting result. The beep statuses are listed as follows:

- OFF: Beep alarm function is OFF.
- NG: Only when the sorting result is NG, buzzer alerts.
- P1: Only when the sorting result is P1, buzzer alerts.
- P2: Only when the sorting result is P2, buzzer alerts.
- P3: Only when the sorting result is P3, buzzer alerts.
- AUX: Only when the sorting result is AUX, buzzer alerts.

Perform the following steps to set the beep status:

- Press **SHIFT** key, and “**SHIFT**” will be displayed on the top left corner of LCD.
- Press **BUZZER** key, the current beep status will be displayed on the LCD as shown in figure 3-7. “**OFF**” is flashing in the primary parameter display area. “**ENTRY**” is also displayed on the top of the LCD, this means that the instrument is under input status and input key functions of **[ESC]**, **[ENTER]**, **[◀]**, **[▶]**, **[▼]**, **[▲]** are enabled.



Figure 3-7 Buzzer beep status setup

- Press **[◀]** or **[▶]** key to select the following beep status in turn: OFF → P1 → P2 → P3 → NG → AUX → OFF.
- Press **[ENTER]** key to save the current displayed beep status and return to the measurement status.
- Press **[ESC]** key to return to the measurement status without changing the previous beep status setup.

3.3.5 Measurement Mode

TH2810D provides 2 kinds of measurement modes:

- CONT: continuous measurement
- TRIG: single trig measurement

Performing the following steps to set the measurement mode:

1. Press **SHIFT** key to enable the secondary function. “**SHIFT**” is displayed on the LCD.
2. Press **CONT/TRIG** key to switch between CONT mode and TRIG mode, and the current measurement mode will be displayed on the bottom of LCD.

3.3.6 Equivalent Circuit

3.3.6.1 Series and Parallel Circuit Setup

TH2810D provides the series and parallel equivalent circuit modes for measuring the L, C, and R.

Perform the following steps to set the equivalent circuit mode

1. Press **SHIFT** key to enable the secondary function. “**SHIFT**” will be displayed on the top left of LCD.
2. Press **SER/PAR** key to switch between the series mode and parallel mode, and the current equivalent circuit mode is displayed on the bottom of LCD.

3.3.6.2 How to Select the Measurement Circuit Mode

■ Guide lines for selecting the capacitance measurement circuit mode.

Small capacitance yields large reactance, which implies that the effect of the parallel resistance has relatively more significance than that of series resistance. The low value of the series resistance has negligible significance compared with the large capacitive reactance, so the parallel circuit mode should be used.

Large capacitance yields small reactance, which implies that the effect of the series resistance has relatively more significance than that of parallel resistance. The large value of the parallel resistance has negligible significance compared with the low capacitive reactance, so the series circuit mode should be used.

The following is a rule of thumb for selecting the circuit mode according to the impedance of the capacitor.

- ◇ Above approx. $10k\ \Omega$: use parallel circuit mode
- ◇ Below approx. $10\ \Omega$: use series circuit mode
- ◇ Between above values: follow the manufacturer's recommendation

■ Guide lines for selecting the inductance measurement circuit mode.

The reactance of a large inductance at a given frequency is relatively large (compared with that of a small inductance), so the parallel resistance becomes more significant than the series component. So, a measurement in the parallel equivalent circuit mode is more suitable.

Conversely, for low values of inductance the reactance becomes relatively small (compared with that of a large inductance), so the series resistance component is more significant. So, the series equivalent circuit mode is the appropriate choice.

The following is a rule of thumb for selecting the circuit mode according to the impedance of the inductor.

- ✧ Below approx. $10\ \Omega$: use series circuit mode
- ✧ Above approx. $10\text{k}\ \Omega$: use parallel circuit mode
- ✧ Between above values: follow the manufacturer's recommendation

3.3.7 RS232 Serial Interface

TH2810D provides the RS232 serial interface to communicate with a PC. All key functions on the panel can be accomplished through the interface, and the measuring settings and results can also be inquired and collected.

Perform the following steps to set the serial interface to ON/OFF

1. Press **SHIFT** key to enable the secondary function. "**SHIFT**" will be displayed on the top left corner of LCD.
2. Press **RS232** key to set the RS232 interface to ON, and "**RS232**" will be displayed on the top right corner of LCD.
3. Repeat step 1 and 2 to set the RS232 interface to OFF, and "**RS232**" will disappear from the LCD screen.

Chapter 4 Handler Interface

4.1 Introduction

TH2810D provides the Handler interface which can provide the control signals and the comparison output signals. As described in table 4-1, the control signals include **/TRIG** (External Trigger signal), **/IDX** (Analog measurement completed signal), and **/EOM** (End of measure and comparison data valid signal). The comparison output signals include **/P1**, **/P2**, **/P3**, **/AUX** and **/NG**. Using these signals, the TH2810D can easily be combined with a component handler and a system controller to fully automate component testing, sorting, and quality control data processing to increase production efficiency.

Table4-1 Handler interface signal description

Signal Name	Description	Specifications
/P1 /P2 /P3	Pass bin signals	■ Build in pull-up resistor ■ Open collector output ■ Negative true ■ Opto-isolated
/NG	No-Good bin signal	
/AUX	Auxiliary bin signal	
/IDX	Analog measurement completed signal	
/EOM	End of measurement	
/TRIG	External trigger signal	
		Pulse width $\geq 1\mu\text{s}$, uprising edge trigger, Low level drive current about 5-10mA.

4.2 Operation

4.2.1 Signal Definition

The handler interface uses three kinds of signals: comparison output, control input and control output.

■ **Comparison output signals:**

/P1, /P2, /P3, /NG, /AUX. See Figure 4-1 signal's area example.

■ **Control output signal:**

/IDX (Analog measurement completed signal)

/EOM (End of measure and comparison data valid signal)

■ **Control input signal:**

/TRIG (External trigger signal)

Notice:

The “/” (black slash) in front of the signal name means that the signal is asserted when LOW.

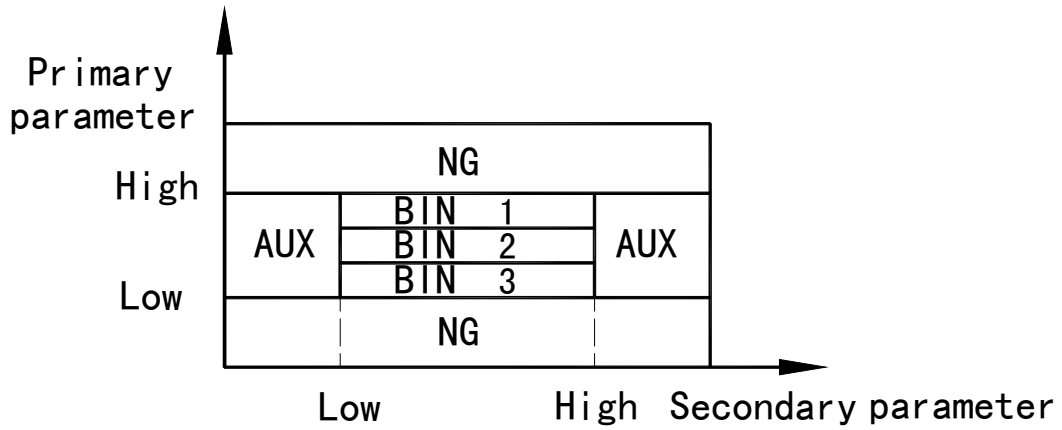

Figure 4-1 /P1, /P2, /P3, /AUX, /NG signal's area example

Contact assignment is described in Table 4-2, Pin assignment for handler interface connector is shown in Figure 4-2 and the timing diagram for handler interface is shown in Figure 4-3.

Table 4-2 Contact Assignments for Handler Interface

Pin No.	Signal Name	Description
1	/P1	Sorting judgments
2	/P2	All signals outputs with build-in pull-up resistor to internal +5V or external power EXTV are open collector and opto-isolated.
3	/P3	
4,5,6	NC	The default pull-up power supply is the external DC power EXTV.
7,8,9	NC	
10	/NG	
11	/AUX	Build-in pull-up resistance is 4.7k Ω .
12,13	/TRIG	External Trigger: TH2810D is triggered on the rising edge of a pulse applied to this pin.
14,15	NC	No Connection
16,17,18	+5V	Internal +5V voltage supply.(max. 0.3A) Generally, internal power supply is not recommended to be used. If it must be used, make sure the current is less than 0.3A.
19,20,21 22,23,24 25,26	NC	No Connection
27,28	EXTV	External DC voltage. DC voltage supply pins for DC isolated open collector outputs (/P1, /P2, /P3, /AUX, /NG) and DC isolated input (/TRIG). Setting of internal jumpers must be changed when using an internal voltage supply.
29	NC	No Connection
30	/IDX	/IDX signal is asserted when an analog measurement is completed and the TH2810D is ready for the next DUT to be connected to the UNKNOWN terminals. The measurement data however, is not valid until /EOM is asserted. (See Figure 4-3).
31	/EOM	End Of Measurement: The signal is asserted when the measurement data and comparison results are valid. (See Figure 4-3).
32,33	NC	No Connection
34,35,36	COM	Common for EXTV When the internal +5V is used for the Handler interface, reference ground of the instrument should be connected with COM.

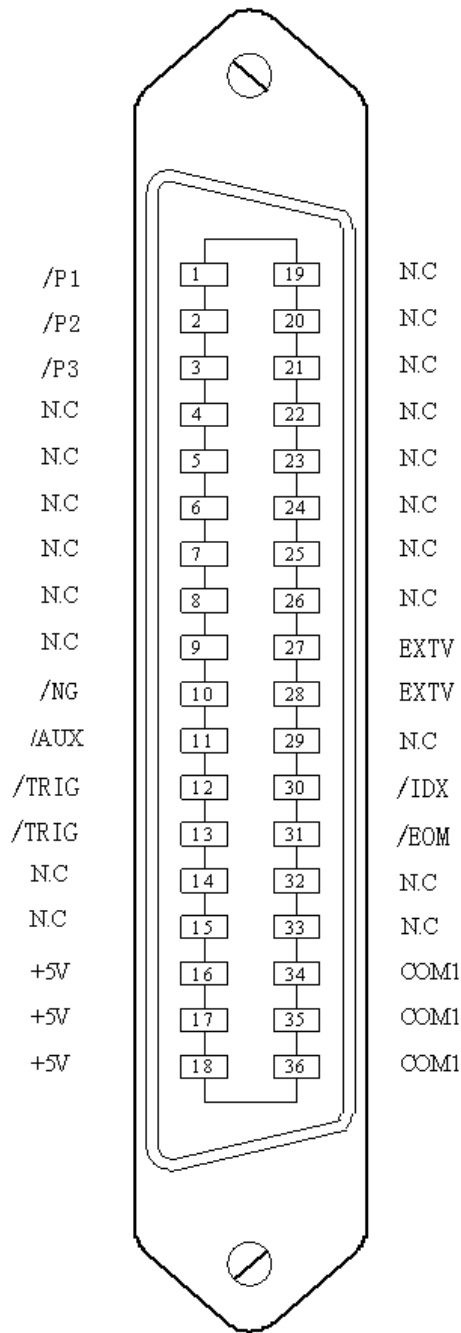
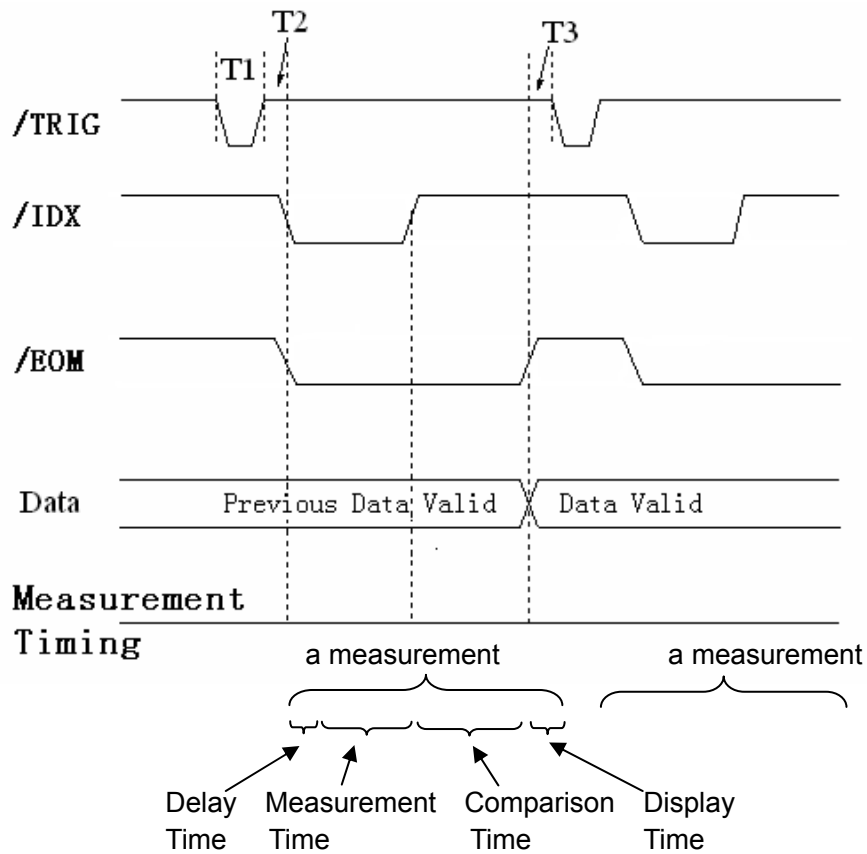

Figure 4-2 Pin Assignment for Handler Interface Connector



	Time	Minimum Value	Maximum Value
T1	Trigger Pulse Width	1 us	---
T2	Measurement Start Delay Time	200us	display + 200us
T3	Trigger Wait Time After /EOM Output	0 us	---

1. Refer to Chapter 3 for measurement time.
2. Typical comparison time is approx. 1ms.
3. Typical display time is approx. 2ms.

Figure 4-3 Timing Diagram for Handler Interface

4.2.2 Electrical Characteristics

DC Isolated Outputs (Opto-coupled)

Every DC output (pins 1 through 3, pins 10 through 11, 30 through 31) is isolated using an open collector output opto-coupler. The output voltage of each line is set by a pull-up resistor in the instrument. The pull-up resistors can be connected to the internally supplied voltage (+5V), or to an externally applied voltage (EXTV: +5V to +24V) by setting jumpers (refer to Figure 4-4).

The electrical characteristics of the DC isolated outputs are described in Table 4-3

Table 4-3 Electrical Characteristics of DC Isolated Output

Output Signals	Voltage Output Rating		Maximum Current	Circuit Common
	Low	High		
/P1 - /P3 /AUX /NG /IDX /EOM	≤0.5V	+5V to +24V	6mA	Internal pull-up voltage: TH2810D circuit common External voltage : COM

DC Isolated Input (Opto-coupled)

The /TRIG signal (pin 12 and 13) is connected to the cathode of the LED in an opto-coupler. The TH2810D is triggered on the rising edge of the /TRIG pulse. The anode of the LED can be powered from the internal +5V supply, or by an external voltage source (EXTV).

A simplified diagram of the output signals and control signals is shown in Figure 4-4

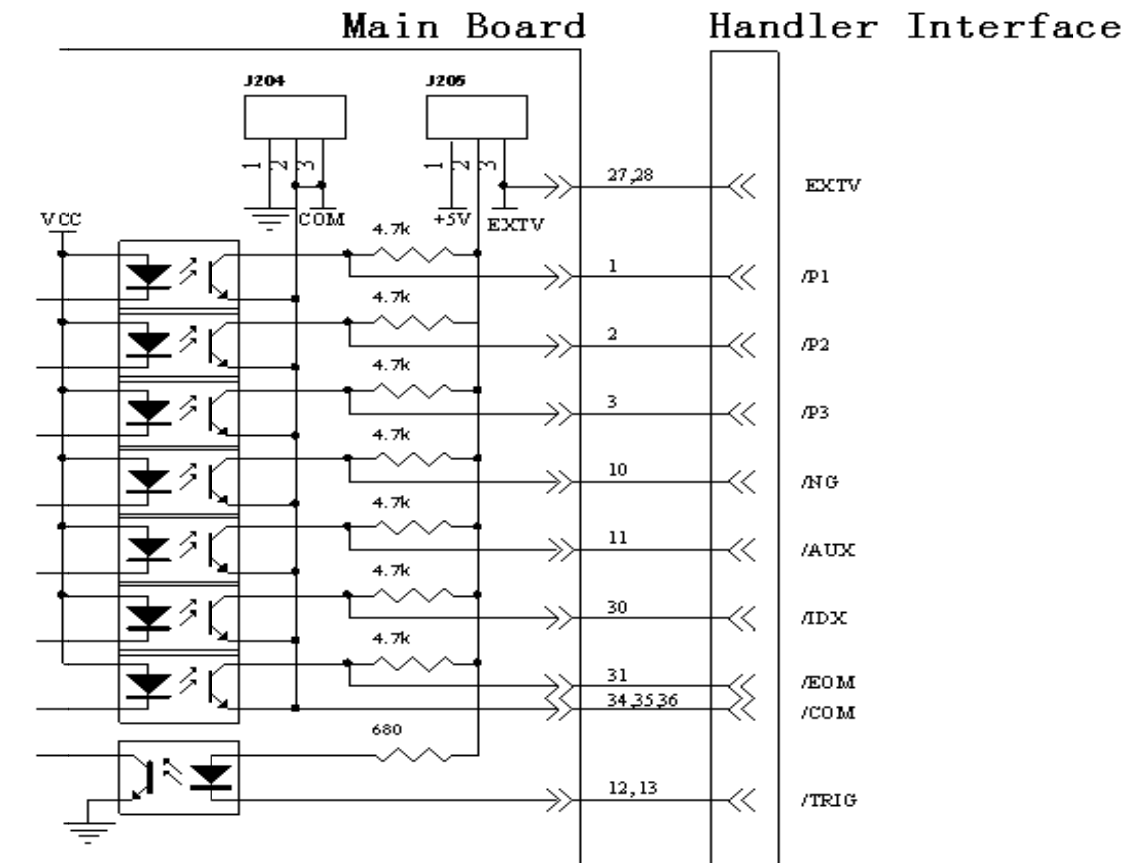

Figure 4-4 Simplified Diagram of output and control signals

- **Use the internal power:**
 Pins 1 and 2 of the jumper J205 should be connected.
 Pins 1 and 2 of the jumper J204 should be connected.
- **Use the external power (Factory default):**
 Pins 2 and 3 of the jumper J205 should be connected.
 Pins 2 and 3 of the jumper J204 should be connected.

Chapter 5 RS232C Serial Interface

5.1 Introduction

RS232C Standard now is widely used as the serial communication standard. RS232 stands for Recommend Standard number 232 and C is the latest revision of the standard. The serial ports on most instruments use a subset of the RS-232C standard. The full RS-232C standard specifies a 25-pin "D" connector of which 22 pins are used. Most of these pins are not needed for normal serial communications, and the common RS232 signals are listed as follows.

Table 5-1 RS-232C Signal Definition

Function	Code	Pin Number of 9 Pin Connector
Request to Send	RTS	7
Clear to Send	CTS	8
Data Set Ready	DSR	6
Data Carrier Detect	DCD	1
Data Terminal Ready	DTR	4
Transmitted Data	TXD	3
Received Data	RXD	2
Signal Ground Common	GND	5

5.2 TH2810D's Serial Interface

TH2810D only used the smallest subset of the RS232C standard, the signals are listed as shown in Table 5-2.

Table 5-2 TH2810D Serial Signals

Function	Code	Pin Number of 9 Pin Connector
Transmit Data	TXD	3
Receive Data	RXD	2

TH2810D's RS232C connector may be different with the standard RS232c. The pin configuration is shown in Figure 5-1.

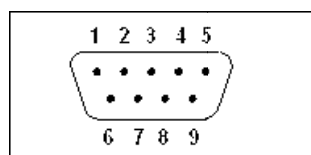

Figure 5-1 RS232C Connector Pin Configuration

A standard DB-9 connector plugs can be connected directly to it.

5.3 Communication with A Computer

There may be some difference between TH2810D RS232C interface and a standard RS232C interface. You can make the connection cable by yourself according to the diagram or order one from our factory.

Note that pin 4 and 6, pin 7 and 8 are shorted respectively at the end of controller.

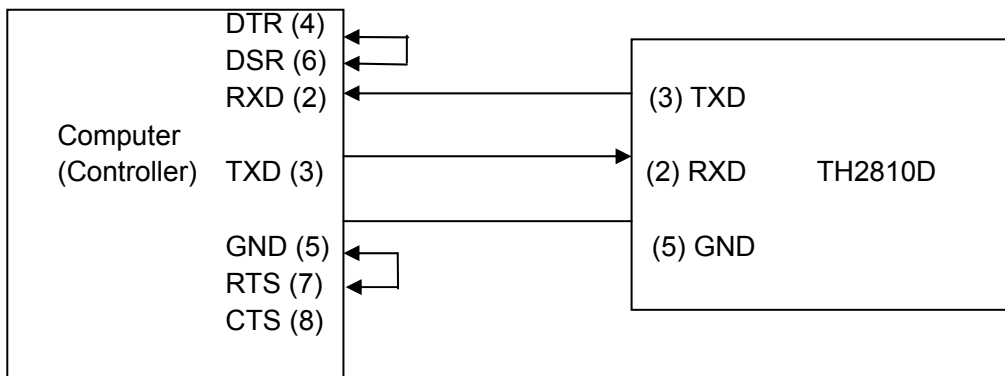

Figure 5-2 The connection between the instrument and a computer

5.4 Serial port parameter

TH2810D'1 serial port parameter is showed as table 5-3

Table 5-3 Serial port parameter

BAUD	9600 bps
DATA	8 BIT
Stop bit	1 BIT
Correction	Null
End symbol	NL (new line symbol, ASCII code is10)
Connector	DB9

5.5 Software Protocol

- 1) For command configuration and format, refer to chapter 6 Command Reference.
- 2) The controller sends the command using the ASCII code with NL as the end character. TH2810D executes the command after the end character NL is received.
- 3) The character received by TH2810D will be sent back to the controller again. The controller will not send the next character until the last return character is received correctively from TH2810D. If the controller cannot receive the character sent back by TH2810D, the reasons may be as follows.

-
- A. The serial interface is not connected correctly.
 - B. Check if the RS232 function is turned on and TALK ONLY function is turned off.
 - C. When TH2810D is executing a bus command, TH2810D will not accept any character through the serial interface at the same time and the character sent by controller will be ignored. In order to make sure the whole command is sent and received correctly, the character without a return character should be sent again by the controller.
- 4) TH2810D sends information under following two conditions. The first is when a character is received normally; TH2810D will send the character back as response. The second is when a query command is received; TH2810D will send the query response information.
 - 5) Once a query command is received, TH2810D will send the query response information immediately even if the whole command has not been executed. So if the command includes two queries, the controller should read the query responses twice. One query is recommended to be included in a single command.
 - 6) A query response is sent out in ASCII codes with NL as the terminal character.
 - 7) Several query responses will be sent continuously with 1ms interval. The controller should be ready to receive the responses; otherwise the response information will be lost.
 - 8) The controller should receive the query response terminal character NL. Otherwise you will confuse a terminal character NL with a returned character. At the same time the controller should receive the last returned character before receiving a query response.
 - 9) For some commands that will take a long time to execute, for example Correction command, the controller should keep waiting to avoid the next command being lost when TH2810D is executing the former command.

Chapter 6 The Specifications

The complete TH2810D specifications are listed below. These specifications are the performance standards. When shipped from the factory, the TH2810D meets the specifications listed in this section.

6.1 Measurement Functions

1. Primary measurement parameters
 - L: Inductance
 - C: Capacitance
 - R: Resistance
 - $|Z|$: Absolute value of impedance
2. Secondary measurement parameters
 - D: Dissipation
 - Q: Quality
3. Combinations of measurement parameters
 - L-Q
 - C-D
 - R-Q
 - Z-Q

6.2 Equivalent Measurement Circuit

- SER: Series equivalent circuit
- PAR: Parallel equivalent circuit

The actual capacitor, resistor and inductor are not the ideal capacitor, resistor and inductor. Normally, a component has the characteristics of the resistor and the reactor at the same time. The actual component is composed of an ideal resistor and a reactor (ideal inductor or capacitor) in series or parallel equivalent circuits.

The value in the two different equivalent circuits can be converted to each other using the following formulas in Table 6-1. The values of L and C in two different equivalent circuits are different due to the quality factor Q (or the dissipation factor D). But D and Q always have the same value in both equivalent circuit modes.

Table 6-1 Equivalent Circuit Transform

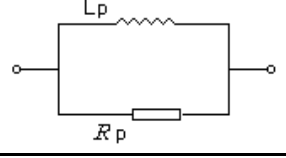
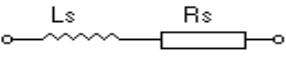
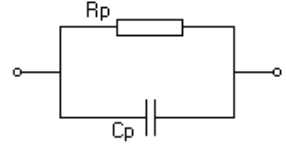
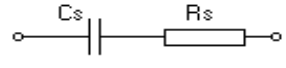
Circuit Mode	Dissipation Factor	Transform
L		$D=2\pi f L_p/R_p=1/Q$ $L_s=L_p/(1+D^2)$ $R_s=R_p D^2/(1+D^2)$
		$D=R_s/2\pi f L_s=1/Q$ $L_p=(1+D^2)L_s$ $R_p=(1+D^2)R_s/D^2$
C		$D=1/2\pi f C_p R_p=1/Q$ $C_s=(1+D^2)C_p$ $R_s=R_p D^2/(1+D^2)$
		$D=2\pi f C_s R_s=1/Q$ $C_p=C_s/(1+D^2)$ $R_p=R_s(1+D^2)/D^2$

Q, D and Xs are defined as follows

$$Q=X_s/R_s$$

$$D=R_s/X_s$$

$$X_s=1/2\pi f C_s=2\pi f L_s$$

Where, Suffix s means series circuit mode, and suffix p means parallel circuit mode. Generally, for low impedance component (such as large capacitor or small inductor), the series equivalent circuit mode should be used. While for high impedance component (such as small capacitor or large inductor), the parallel equivalent circuit mode is the appropriate choice. We also select the equivalent circuit mode according to the actual usage in different circuits. If a capacitor is used as a filter capacitor, series circuit mode is the best choice. If a capacitor is used in a LC oscillator, then the parallel circuit mode should be selected.

6.3 Measurement Range

When TH2810D is operated under 100Ω signal source output resistance, 5 ranges are available: 30Ω, 100Ω, 1kΩ, 10kΩ and 100kΩ. When TH2810D is operated under 30Ω signal source output resistance, 6 ranges are available: 10Ω, 30Ω, 100Ω, 1 kΩ, 10 kΩ and 100 kΩ.

Range AUTO or range HOLD mode can be selected for measurement ranging operation.

6.4 Trigger Mode

TH2810D provides 4 kinds of trigger modes for selection. They are Internal, External, Bus and Manual.

- **Internal:** When the measurement mode is set to “CONT”, TH2810D is triggered automatically. TH2810D performs measurements continuously.
- **External:** When the measurement mode is set to “TRIG” and the handler interface is enabled, TH2810D performs a single measurement every time a low-to-high transition TTL level signal is applied to the handler interface on the rear panel.
- **Bus:** When the measurement mode is set to “TRIG”, TH2810D performs a signal measurement every time the “TRIG IMM” command is sent to the TH2810D via the RS232 interface.
- **Manual:** When the measurement mode is set to “TRIG”, TH2810D performs a single measurement every time when **TRIGGER** key on the panel is pressed.

6.5 Measurement Terminals

4 Measurement Terminals

H_{CUR}: High current

H_{POT}: High potential

L_{POT}: Low potential

L_{CUR}: Low current

6.6 Measurement Speed

TH2810D's measurement speed is determined by integration time, measurement result display time, ranging mode and comparator on/off etc. Three kinds of measurement speeds can be selected by user, FAST, MED and SLOW. Generally, slower measurement speed will result in more stable and accurate measurement results.

FAST Speed: 10 meas/sec

MED Speed: 4.0 meas/sec

SLOW Speed: 2.5 meas/sec

6.7 Basic Accuracy

C: $0.1\% (1 + C_x/C_{max} + C_{min}/C_x)(1 + D_x)(1 + k_s + k_v + k_f)$;

L: $0.1\% (1 + L_x/L_{max} + L_{min}/L_x)(1 + 1/Q_x)(1 + k_s + k_v + k_f)$;

Z: $0.1\% (1 + Z_x/Z_{max} + Z_{min}/Z_x)(1 + k_s + k_v + k_f)$;

R: $0.1\%(1 + R_x/R_{max} + R_{min}/R_x)(1 + Q_x)(1 + k_s + k_v + k_f)$;

D: $\pm 0.0010(1 + Z_x/Z_{max} + Z_{min}/Z_x)(1 + D_x + D_x^2)(1 + k_s + k_v + k_f)$;

Q: $\pm 0.0015(1 + Z_x/Z_{max} + Z_{min}/Z_x)(Q_x + 1/Q_x)(1 + k_s + k_v + k_f)$;

where,

1. D, Q is the absolute deviation, the rest are the percent deviations, $Dx=1/Qx$;
2. Parameters with suffix “x” are measured results. Parameters with suffix “max” are the maximum values listed in Table 6-2. Parameters with suffix “min” are the minimum values listed in Table 6-2.
3. k_s is the speed factor, k_v is the voltage level factor, k_f is the frequency factor.
4. When calibration measurement is performed, reliable open and short corrections should be taken for better measurement accuracy.

6.7.1 Maximum and Minimum Values Used for Accuracy Calculation

Table 6-2 Maximum and Minimum values

Parameter	Frequency			
	100Hz	120Hz	1kHz	10kHz
Cmax	800 μ F	667 μ F	80 μ F	8 μ F
Cmin	1500pF	1250pF	150pF	15pF
Lmax	1590H	1325H	159H	15.9H
Lmin	3.2mH	2.6mH	0.32mH	0.032mH
Zmax	1M Ω			
Zmin	1.59 Ω			

6.7.2 Measurement Speed Factor k_s

Slow: $k_s=0$;
 Medium: $k_s=0$;
 Fast: $k_s=10$.

6.7.3 Measurement Voltage Level Factor k_v

1.0Vrms: $k_v=0$;
 0.3Vrms: $k_v=1$;
 0.1Vrms: $k_v=4$.

6.7.4 Measurement Frequency Factor k_f

100Hz: $k_f=0$;
 120Hz: $k_f=0$;
 1kHz: $k_f=0$;
 10kHz: $k_f=0.5$;

6.8 Measurement Frequency

TH2810D provides 4 kinds of test frequencies: 100Hz, 120Hz, 1kHz and 10kHz.
 Accuracy: $\pm 0.02\%$

6.9 Test Signal Level

0.1 Vrms±10%

0.3 Vrms±10%

1.0 Vrms±10%

6.10 Output Impedance

30Ω±5%

100Ω±5%

6.11 Display Range

Parameter	Frequency	Measuring
L	100Hz、120Hz	1μH to 99999H
	1kHz	0.1μH to 99999H
	10kHz	0.01μH to 99999H
C	100Hz、120Hz	1pF to 99999μF
	1kHz	0.1pF to 99999μF
	10kHz	0.01pF to 99999μF
R,Z		0.1mΩ to 99.9MΩ
Q		0.0001 to 99999
D		0.0001 to 9.9999

6.12 Correction Function

Open Correction

Open correction eliminates measurement errors due to parasitic stray impedances of the test fixture.

Short Correction

Short correction eliminates measurement errors due to parasitic residual impedances of the test fixture.

6.13 Comparator Function

TH2810D's built-in comparator can sort devices into a maximum of 4 bins (P1, P2, P3 and NG) using a maximum of three pairs of primary limits and one pair of secondary parameter limits. Also, a device whose primary parameter is within limits, but whose secondary parameter measurement result is not within limits can be sorted into an AUXiliary bin. The comparator function is especially useful when using the TH2810D with a component handler.

6.14 Ranging Mode

AUTO:

TH2810D automatically selects the appropriate range according to the DUT's impedance.

HOLD:

The measurement range is fixed at the current setting.

6.15 Beep Function

- OFF Beeper is turned off.
- P1 Alarm when sorted into P1 bin
- P2 Alarm when sorted into P2 bin
- P3 Alarm when sorted into P3 bin
- AUX Alarm when sorted into AUX bin

6.16 RS232 Interface

Baud rate: fixed 9600bps

Maximum transmission distance: 15 m

The programming language is SCPI. All commands and data are transmitted using the ASCII codes over the bus.

6.17 HANDLER interface

TH2810D can receive the Trigger signal and output the comparison results through the HANDLER interface.

Synchronous signal /IDX and /EOM can be outputted.

The output signals are logical low active and opto-isolated.

TH2810D's output signals have pull-up resistor on the handler interface board. External DC source supply is used as the default power supply when shipped from the factory.

Chapter 7 Command Reference

7.1 Introduction

This chapter describes all of the TH2810D's available RS232C commands which correspond to Standard Commands for Programmable Instruments (SCPI) command sets. Each command description contains the following paragraphs:

Field	A field name corresponding to a SCPI command.
Command Syntax	The way you must type in the command, including all of the required and optional parameters.
Query Syntax	The way you must type in the query, including all of the required and optional parameters.
Query Response	TH2810D's response data format.

7.2 Notation Conventions and Definitions

The following conventions and definitions are used in this chapter to describe RS232 operation.

- < > Angular brackets enclose word or characters that are used to symbolize a program code parameter or a RS232 command.
- [] Square brackets indicates that the enclosed items are optional.
- { } When several items are enclosed by braces, one and only one of these elements may be selected.

The following definitions are used:

- <NL> Terminators (New Line or ASCII Line Feed character (decimal 10))
- White space Single ASCII character (0-9, 11-32 decimal)
For example, Carriage Return (13 decimal) or Space (32 decimal).

7.3 Command Structure

The TH2810D commands are divided into two types: Common commands and SCPI commands. The common commands are defined in IEEE std, and these commands are common for all devices. The SCPI commands are tree structured three levels deep. The highest level commands are called the subsystem commands in this manual. So the lower level commands are legal only when the subsystem commands have been selected. A colon (:) is used to separate the higher level commands and the lower level commands.

The basic rules of the command tree are as follows.

- Letter case (upper and lower) is ignored.
For example,
LIMIT:NOMINAL <value> = limit:nominal <value> = LiMiT:NoMiNaL <value>

- Spaces (␣ used to indicate a space) must not be placed before and/or after the colon(:).
For example,
(wrong) **LIMIT␣:␣NOMINAL <value>**
(right) **LIMIT:NOMINAL <value>**

- The command can be fully spelled out or in abbreviated.
For example,
LIMIT:NOMINAL <value> = LIM:NOM <value>

- The command header should be followed by a question mark (?) to generate a query for that command.
For example,
LIMIT:NOMINAL_C ?

The semicolon (;) can be used as a separator to execute multiple commands on a single line. The multiple command rules are as follows.

- Commands at the same level and in the same subsystem command group can be separated by a semicolon (;) on a multiple command line.
For example,
LIMIT:NOMINAL <value>; BIN <n> <low limit>,<high limit>

- To restart commands from the highest level, a semicolon (;) must be used as the separator, and then a leading colon (:), which shows that the restarted command is a command at the top of the command tree, must follow.
For example,
LIMIT:NOMINAL <value>;:LIMIT:BIN <n> <low limit>,<high limit>

7.4 Command Abbreviations

Every command and character parameter has at least two forms, a short form and a long form. In some cases they will be the same. The short form is obtained using the following rules.

- If the long form has four characters or less, the long form and short form are the same.
- If the long form has more than 4 characters,
If the 4th character is a vowel, the short form is the first 3 characters of the long form.
If the 4th character is not a vowel, the short form is the first 4 characters.

For example:

LIMIT abbreviates to **LIM**.

RANGE abbreviates to **RANG**.

FREQUENCY abbreviates to **FREQ**.

- If the long form mnemonic is defined as a phrase rather than a single word, then long form mnemonic is the first character of the first word(s) followed by the entire last word. The above rules, when the long form mnemonic is a single word, are then applied to the resulting long form mnemonic to obtain the short form.

For example:

Source RESistor abbreviates to **SRES**. The long form is **SRESISTOR**.

7.5 Header and Parameters

The TH2810D control command consists of a command header and parameters.

Headers can be of the long form or the short form. The long form allows easier understanding of the program code and the short form allows more efficient use of the computer. Parameters may be of two types as follows.

- **Character Data and String Data**

Character data consists of ASCII characters. The abbreviation rules are the same as the rules for command headers. String data consists of ASCII characters enclosed by double quotes(" ").

- **Numeric Data**

Integer (NR1), fixed point (NR2), or floating point (NR3). The available range for numeric data is $\pm 9.9E37$.

Examples for NR1:

123

+123

-123

Examples for NR2:

12.3

+1.234

-123.4

Examples for NR3:

12.3E+5

123.4E-56

7.6 Command Description.

7.6.1 SPEED Command

The SPEED command sets the measurement speed of TH2810D. The SPEED? query returns the current measurement speed setting.

Command Syntax:

SPEED { FAST
MEDium
SLOW }

Where,

FAST fast measurement speed, approx. 10 meas/sec.

MEDium medium measurement speed, approx 4 meas/sec.

SLOW slow measurement speed, approx 2.5 meas/sec.

Query Syntax:

SPEED?

Query Response:

{ FAST
MED
SLOW }, <NL>

7.6.2 DISPlay Command

The DISPlay command sets the display format of the measurement results. The DISPlay? query returns the current setting of the display format of the measurement results.

Command Syntax:

DISPlay { DIRect
PERcent
ABSolute }

Where,

DIRect Direct reading display mode.

PERcent Percent deviation display mode.

ABSolute Absolute deviation display mode.

Query Syntax:

DISPlay?

Query Response:
$$\left. \begin{array}{l} \text{DIRECT} \\ \text{PERCENT} \\ \text{ABSOLUTE} \end{array} \right\} \langle \text{NL} \rangle$$
7.6.3 FREQUENCY Command

The FREQUENCY command sets the signal source frequency. The FREQUENCY? query returns the current test frequency.

Command Syntax:
$$\text{FREQUENCY} \left\{ \begin{array}{l} 100 \\ 120 \\ 1\text{K} \\ 10\text{K} \end{array} \right\}$$

Where,

100	Set measurement frequency to 100 Hz.
120	Set measurement frequency to 120 Hz.
1K	Set measurement frequency to 1 kHz.
10K	Set measurement frequency to 10 kHz.

Query Syntax:

FREQUENCY?

Query Response:
$$\left\{ \begin{array}{l} 100 \\ 120 \\ 1\text{K} \\ 10\text{K} \end{array} \right\}, \langle \text{NL} \rangle$$
7.6.4 PARAMETER Command

The PARAMETER command sets the primary and secondary measurement parameter combination. The PARAMETER? query returns the current primary and secondary measurement parameter combination.

Command Syntax:
$$\text{PARAMETER} \left\{ \begin{array}{l} \text{CD} \\ \text{RQ} \\ \text{ZQ} \\ \text{LQ} \end{array} \right\}$$

Where,

CD Set measurement parameter combination to C-D.
RQ Set measurement parameter combination to R-Q.
ZQ Set measurement parameter combination to Z-Q.
LQ Set measurement parameter combination to L-Q.

Query Syntax:

PARAMeter?

Query Response:

$\left. \begin{array}{c} \text{CD} \\ \text{RQ} \\ \text{ZQ} \\ \text{LQ} \end{array} \right\}, <\text{NL}>$

7.6.5 LEVel Command

The LEVel command sets the oscillator's output voltage level. The LEVel? query returns the current oscillator voltage level.

Command Syntax:

LEVel $\left\{ \begin{array}{c} 1.0\text{V} \\ 0.3\text{V} \\ 0.1\text{V} \end{array} \right\}$

Where,

1.0V Set the oscillator's output voltage level to 1.0V.
0.3V Set the oscillator's output voltage level to 0.3V.
0.1V Set the oscillator's output voltage level to 0.1V.

Query Syntax:

LEVel?

Query Response:

$\left\{ \begin{array}{c} 1.0\text{V} \\ 0.3\text{V} \\ 0.1\text{V} \end{array} \right\}, <\text{NL}>$

7.6.6 SRESistor Command

The SRESistor command sets the signal source output resistor. The SRESistor? query returns the current setting of the signal source output resistor.

Command Syntax:

$$\text{SRESistor} \left\{ \begin{array}{l} 30 \\ 100 \end{array} \right\}$$

Where,

30 Set the signal source output resistor to 30 Ω .

100 Set the signal source output resistor to 100 Ω .

Query Syntax:

SRESistor?

Query Response:

$$\left\{ \begin{array}{l} 30 \\ 100 \end{array} \right\}, <\text{NL}>$$

7.6.7 TRIGger Command

The TRIGger command is used to trigger a measurement and to set the trigger mode.

Command Syntax:

$$\text{TRIGger} \left\{ \begin{array}{l} \text{INTernal} \\ \text{EXTernal} \\ \text{IMMediate} \end{array} \right\}$$

Where,

INTernal Set the trigger mode to internal trigger mode.

EXTernal Set the trigger mode to external trigger mode.

IMMediate Trigger a measurement immediately.

Query Syntax:

TRIGger?

Query Response:

$$\left\{ \begin{array}{l} \text{INTERNAL} \\ \text{EXTERNAL} \end{array} \right\}, <\text{NL}>$$

7.6.8 CORRection Command

The CORRection command executes the OPEN or SHORt correction for all frequencies over the specified voltage level and signal source output resistor.

Command Syntax:

$$\text{CORRection} \left\{ \begin{array}{l} \text{OPEN} \\ \text{OPEN_ALL} \\ \text{SHORt} \\ \text{SHORt_ALL} \end{array} \right\}$$

Where,

- OPEN Execute the OPEN correction for all frequencies over the specified voltage level and signal source output resistor.
- OPEN_ALL Execute the OPEN correction for all frequencies and all voltage levels.
- SHORt Execute the SHORt correction for all frequencies over the specified voltage level and signal source output resistor.
- SHORt_ALL Execute the SHORt correction for all frequencies and all voltage levels.

7.6.9 COMParator Command

The COMParator command sets the comparator function to ON or OFF. The COMParator? query responds the current ON/OFF condition of the comparator function.

Command Syntax:

$$\text{COMParator} \left\{ \begin{array}{l} \text{ON} \\ \text{OFF} \end{array} \right\}$$

Where,

- ON Turn on the comparator funciton.
- OFF Turn off the comparator function.

Query Syntax:

COMParator?

Query Response:

$$\left\{ \begin{array}{l} \text{ON} \\ \text{OFF} \end{array} \right\}, <\text{NL}>$$

7.6.10 EQUivalent Command

The EQUivalent command set the equivalent circuit mode for measurement. The EQUivalent? query responds the current equivalent circuit used for measurement.

Command Syntax:

EQUivalent $\left\{ \begin{array}{l} \text{SERial} \\ \text{PARallel} \end{array} \right\}$

Where,

SERial Set the equivalent circuit mode to serial circuit mode.

PARallel Set the equivalent circuit mode to parallel circuit mode.

Query Syntax:

EQUivalent?

Query Response:

$\left\{ \begin{array}{l} \text{SERIAL} \\ \text{PARALLEL} \end{array} \right\}, <\text{NL}>$

7.6.11 RANGe Command

The RANGe command sets the ranging mode: AUTO mode or HOLD mode. This command can also be used to set the current measurement range. The RANGe? query returns the current ranging mode together with the current measurement range.

Command Syntax:

RANGe $\left\{ \begin{array}{l} \text{AUTO} \\ \text{HOLD} \\ 0 \\ 1 \\ 2 \\ 3 \\ 4 \\ 5 \end{array} \right\}$

Where,
 AUTO Set the ranging mode to AUTO.
 HOLD Set the ranging mode to HOLD.
 0 to 5 Set the current measurement range.

Query Syntax:

RANGE?

Query Response:

$$\left\{ \begin{array}{l} \text{AUTO-}<n> \\ \text{HOLD-}<n> \end{array} \right\}, <NL>$$

7.6.12 ALARm Command

The ALARm command sets which Bin is to be alarmed. ALARm? query returns the current BIN to be alarmed.

Command Syntax:

$$\text{ALARm} \left\{ \begin{array}{l} \text{OFF} \\ \text{AUX} \\ \text{P3} \\ \text{P2} \\ \text{P1} \\ \text{NG} \end{array} \right\}$$

Where,
 OFF Set the alarm function to OFF.
 AUX Set the alarm BIN to AUX.
 P3 Set the alarm BIN to P3
 P2 Set the alarm BIN to P2
 P1 Set the alarm BIN to P1
 NG Set the alarm BIN to NG

Query Syntax:

ALARm?

Query Response:

$$\left\{ \begin{array}{l} \text{OFF} \\ \text{AUX} \\ \text{P3} \\ \text{P2} \\ \text{P1} \\ \text{NG} \end{array} \right\}, <NL>$$

7.6.13 LIMit Subsystem

LIMit:NOMinal

The LIMit:NOMinal command sets the nominal value for the tolerance mode of the comparator function. The LIMit:NOMinal? query returns the current settings of the nominal value for the tolerance mode.

Command Syntax:

```
LIMit:NOMinal_C <value>  
LIMit:NOMinal_L <value>  
LIMit NOMinal_Z <value>  
LIMit NOMinal_R <value>
```

Where,

<value> NR1, NR2, NR3 format nominal value

Query Syntax:

```
LIMit:NOMinal_C?  
LIMit:NOMinal_L?  
LIMit NOMinal_Z?  
LIMit NOMinal_R?
```

Query Response:

<NR3> <NL>

LIMit:BIN<n>

The LIMit:BIN <n> command sets the low/high limit values of each BIN for the comparator function tolerance mode. The LIMit:BIN <n>? query returns the current settings of the low/high limit value for each of the BINS.

Command Syntax:

```
LIMit:BIN <n> <low limit>,<high limit>
```

Where,

<n> 1 to 3 (NR1), BIN number
<low limit> NR1, NR2, NR3 format low limit value
<high limit> NR1, NR2, NR3 format high limit value

Query Syntax:

```
LIMit:BIN <n>?
```

Query Response:

<low limit >,<high limit> <NL>

LIMit:SECondary

The LIMit:SECondary command sets the low/high limit values of the secondary parameters for comparator function. Low limit of the secondary parameter is the low limit of quality factor and high limit of the secondary parameter is the high limit of dissipation factor. The

LIMit:SECondary? query returns the current settings of the secondary parameter low/high limit values.

Command Syntax:

LIMit:SECondary <low limit>,<high limit>

Where,

<low limit> NR1, NR2, NR3 format low limit value

<high limit> NR1, NR2, NR3 format high limit value

Query Syntax:

LIMit:SECondary?

Query Response:

<low limit >,<high limit> <NL>

7.6.14 FETCh? Query

The FETCh? query returns the latest measurement data of the primary and secondary parameters.

Query Syntax:

FETCh?

Query Response:

<primary>,<secondary> <NL>